



NEW

Extruders for plastic & rubber





Contents

1	Rossi for You	4
	1.1 Global presence, local service	6
2	Product Overview	8
	2.1 Features & Benefits	10
	2.2 Plastic & rubber recycling	12
3	Extruder supports - Designs and dimensions	14
	3.1 Extruder support N	16
	3.2 Extruder support H	17
4	Technical features	18
	4.1 General	20
	4.2 Thermal index of extruder support	20
	4.3 Designs, dimensions, mounting positions, weight and oil quantity	21
	4.4 Radial loads on high speed shaft end & gear reducer input face	21
	4.5 Gearmotor input face	21
	4.6 Lubrication	22
	4.7 Plug positions and dimensions	23
	4.8 Cooling systems	24
	4.9 Plate heat exchanger with driven pump	26
	4.10 Rear extraction of extruder shaft	30
	4.11 Technical formulae	31
	4.12 Gear selection form	32

Rossi for You



Innovation

Rossi S.p.A. offers a wide range of solutions for an evolving industry, flexible and innovative gear reducers and gearmotors for customer tailored solutions to maximize performances and minimize the Total Cost of Ownership (TCO).



High quality, 3 years warranty

Our drive is to innovate and boost operations by manufacturing performing, precise, reliable and high-quality products all over the world. We are always one step forward in offering and developing solutions that can satisfy an unlimited number of application needs, even in the most demanding conditions.



Reliability

We are a reliable company with the right flexibility and know-how to respond to worldwide market requests, in all application fields, without leaving aside our commitment for the environment and value on human safety, to protect everyone's future.



Tools and processes

We continue to invest in new tools and processes, so our highly skilled specialist team in different fields are supporting you to find the best solution suitable for your demands, always by your side on every step of the project.



After-sale service

Highly trained mechanics and support teams can ensure a fast and efficient after-sale service providing support worldwide.



Digital support

Alongside our 24/7 Rossi for You portal you have a suite of digital support tools enabling real time access to your order tracking, invoices, spare part tables download and contact to our service.

70
YEARS

Experience

Shaped by more than 70 years of history Rossi meets your unique needs whether you need a standard design or a customized solution.



Global presence local service



Local support

Sales, customer service,
technical support, spare parts



15 branches*



Worldwide distribution network*

A global network of subsidiaries and dealers.
From design and execution to after sales service.
Rossi S.p.A. is always close to you, a local reliable and
flexible partner.

Alongside our 24/7 **Rossi for You** portal you have a suite
of digital support tools enabling real time access to your
order tracking, invoices, spare part tables download and
contact to our service.

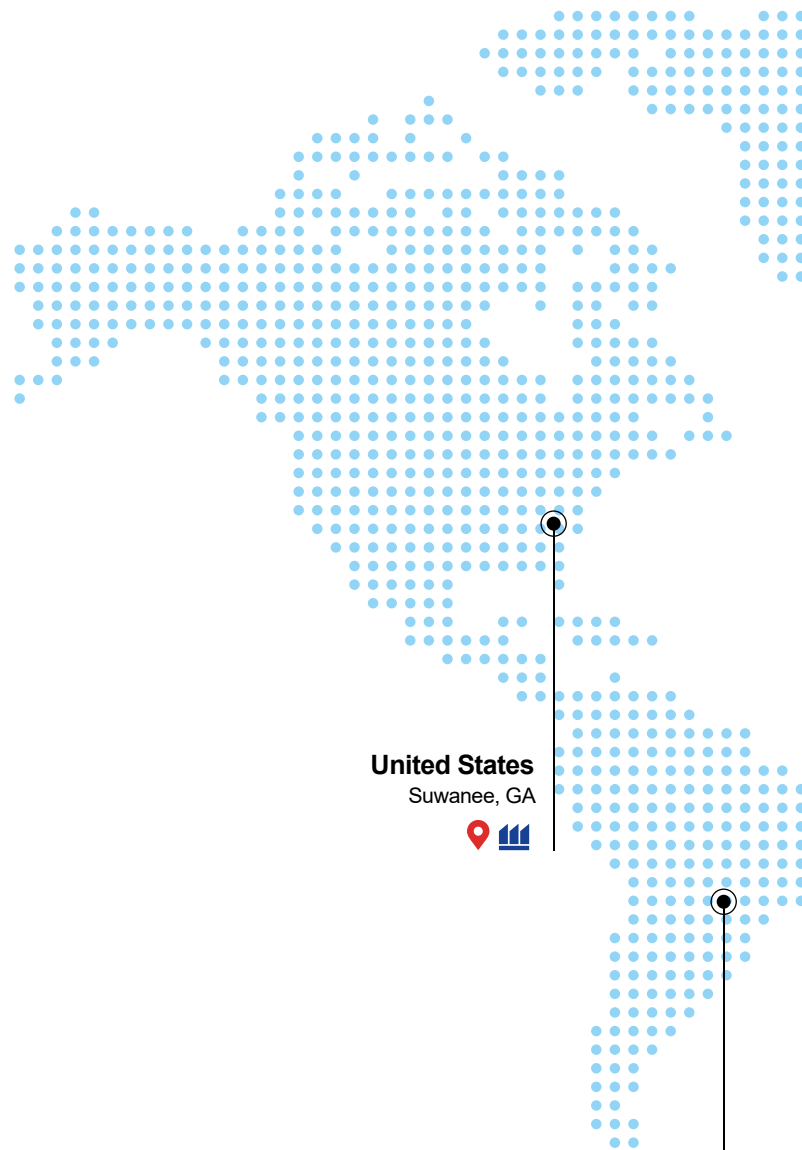

United States
Suwanee, GA



Brazil
Cordeiropolis, SP



*All contacts available on www.rossi.com



Headquarters



Branches



Production facilities/Assembly plants

United Kingdom

Coventry



Netherlands

Panningen



Germany

Dreieich



Poland

Wroclaw



Turkey

Izmir



China

Shanghai



Souzhou



Taiwan

Kaohsiung City



Spain

Barcelona



France

Saint Priest



Italy

Modena



Ganaceto



Lecce



Sud Africa

La Mercy



India

Coimbatore



Australia

Perth



Malesia

Kuala Lumpur



Product Overview

Section contents

2.1 Features & Benefits

10

2.1

Features & Benefits

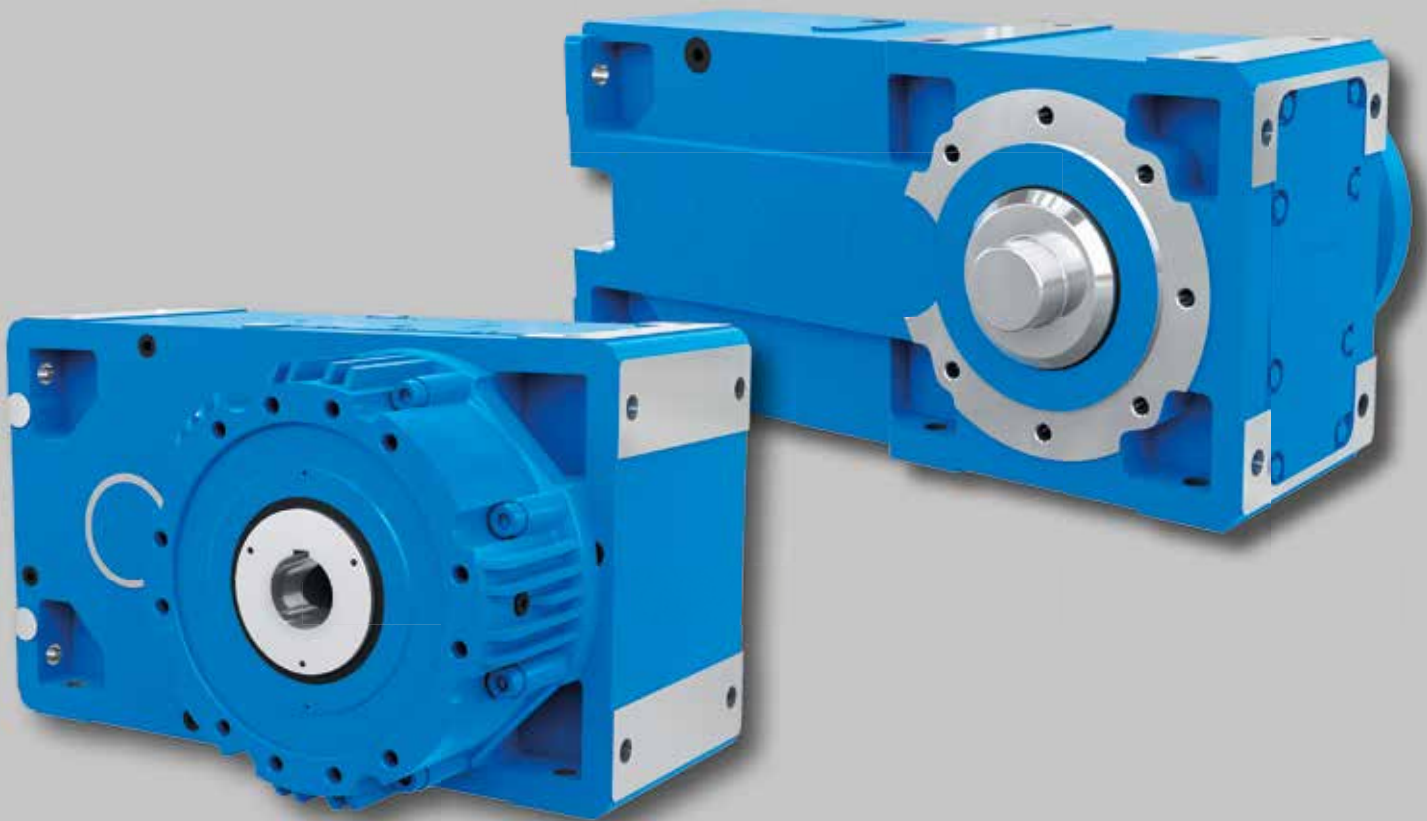



Maximum performance

We drive the heaviest applications worldwide

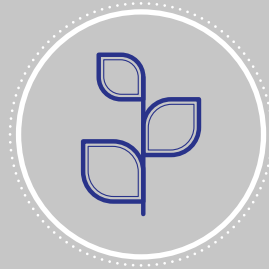

Sustainability

We care about environment

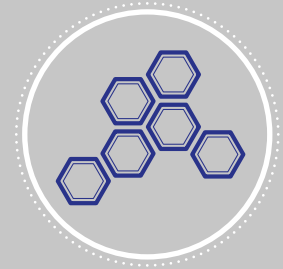

Modular system

For cost-effective and high quality solutions



Innovation

We are constantly thinking forward, solutions for an evolving industry



Digitalization

Rossi for You is always at your disposal for any info



Know-how

We support you through interdisciplinary know-how

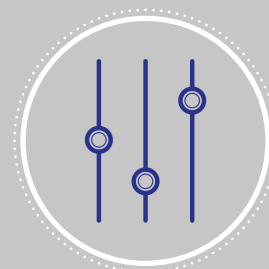

Customization

Cost-effective solutions starting from standard products

Plastic & rubber recycling

Nowadays recycling becomes more and more important for several industrial fields: plastic & rubber are among the front runners in recycling process.

Rossi, with its extensive manufacturing program, offers a complete drive solution connected with the whole recycling process.

Thanks to its cutting edge technology, Rossi products - gear reducers and electric motors - ensure top performances in terms of efficiency, and help reduce CO₂ emissions, keeping world environment safer and greener.



Helical and bevel helical gear units in extruder design about plastic or rubber extrusion



Shredders

Nowadays recycling becomes more and more important for several industrial fields: plastic & rubber are among the front runners in recycling process.

Rossi, with its extensive manufacturing program, offers a complete drive solution connected with the whole recycling process.

Thanks to its cutting edge technology, Rossi offers helical and bevel helical gear reducers with hollow low speed shaft with keyway or shrink disc or splined. Products ensure top performances in terms of efficiency, and help reduce CO₂ emissions, keeping world environment safer and greener.

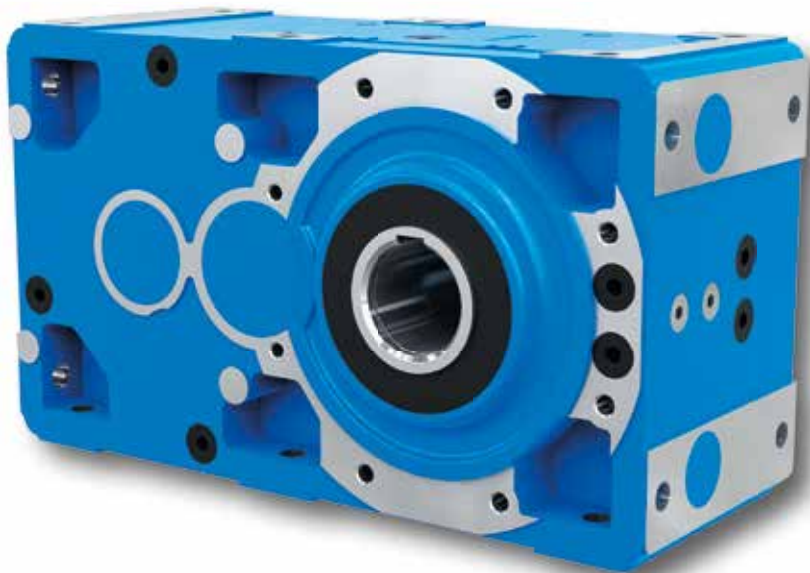

Helical and bevel helical gear units in shredder design



Extruder supports - Designs and dimensions

Section contents

3.1	Extruder support N	14
3.2	Extruder support H	15

3.1

Extruder support N

140 ... 321

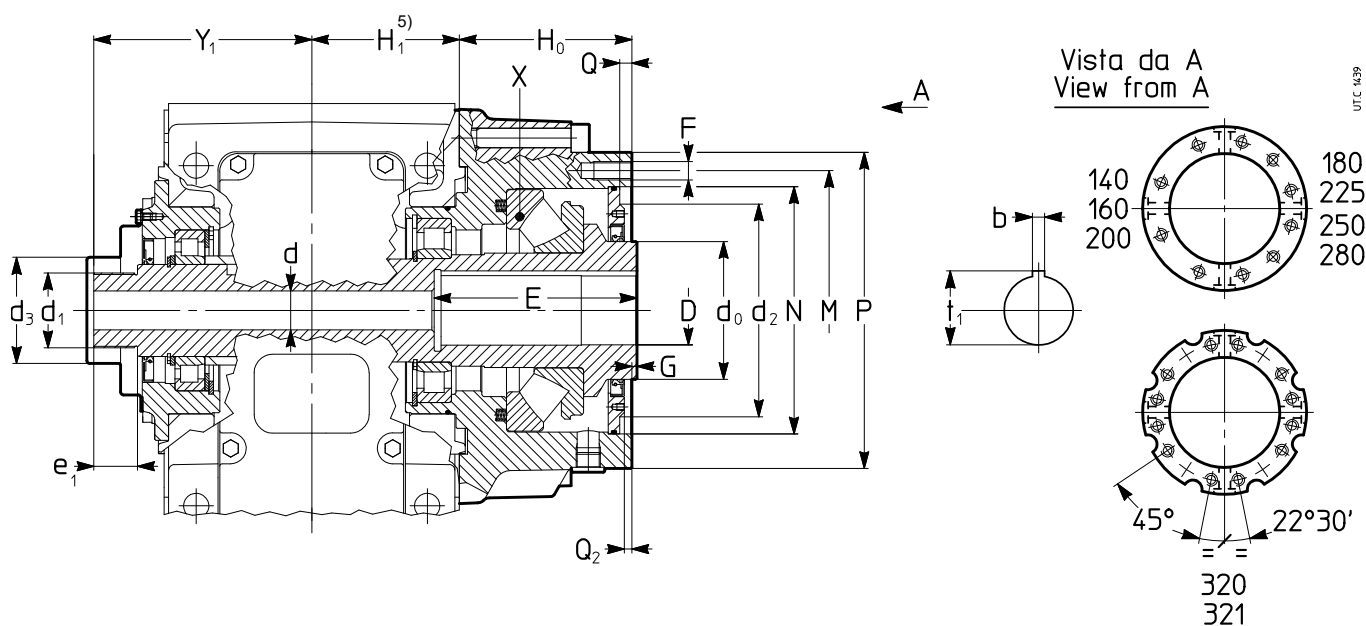

Size	Bearing		Design N																			
	X	C	D ¹⁾ ∅	E ¹⁾⁴⁾	b	d	d ₀	d ₁	d ₂	d ₃	e ₁	F ²⁾³⁾	G	H ₀	M ²⁾ ∅	N ²⁾ ∅	P ²⁾ ∅	Q	Q ₂	t ₁	Y ₁	
		kN	H7							≈						H7		0 +0,5			≈	
140	294 17E	633	40	103	12	34	110	M50 × 1,5	110	74	30	M16 ⁸⁾	1	131	208	180,5	240	8	8	43,3	165	
160	294 17E	633	50	118	14	34	110	M65 × 2	110	84	40	M16 ⁸⁾	1	131	208	180,5	240	8	8	53,8	191	
180	294 20E	863	60	133	18	34	120	M65 × 2	180	93	40	M16 ¹²⁾	1	150	243	215	275	10	6,5	64,4	190	
200	294 22E	1 010	70	133	20	43	130	M85 × 2	200	113	45	M20 ⁸⁾	1	164	278	243	318	10	8,5	74,9	212	
225	294 26E	1 380	80	158	22	43	160	M85 × 2	250	113	45	M20 ¹²⁾	1	182	318	283	358	10	5,5	85,4	224	
250	294 30E	1 610	90	158	25	43	200	M85 × 2	319	143	45	M24 ¹²⁾	1,5	222	400	358	450	12	10,5	95,4	251	
280	294 34E	2 020	100	188	28	43	200	M90 × 2	319	143	45	M24 ¹²⁾	1,5	222	400	358	450	12	10,5	106,4	267	
320, 321	294 40E	2 760	110	188	28	72	240	M120 × 2	361	173	45	M30 ¹²⁾	1,5	277	535	483	595	12	8	116,4	306	

1) Other D×E values available on request: consult us.

2) Other flanges available on request: consult us.

3) Working length of thread 2 · F.

4) E dimension includes machining relief and is often higher than the shank length; when the screw shoulder must be on hole bottom – upon technical approval; consult us –, state it in full in the designation (see ch. 3 on GX catalog).

5) For H₁ dimension, see pag. 20 ... 22 on GX catalog.

Different type of thrust bearings (294 ...) could be available in addition to the a.m. stated ones. In case these could be requested, contact Rossi S.p.A.

3.2

Extruder support H

100 ... 360

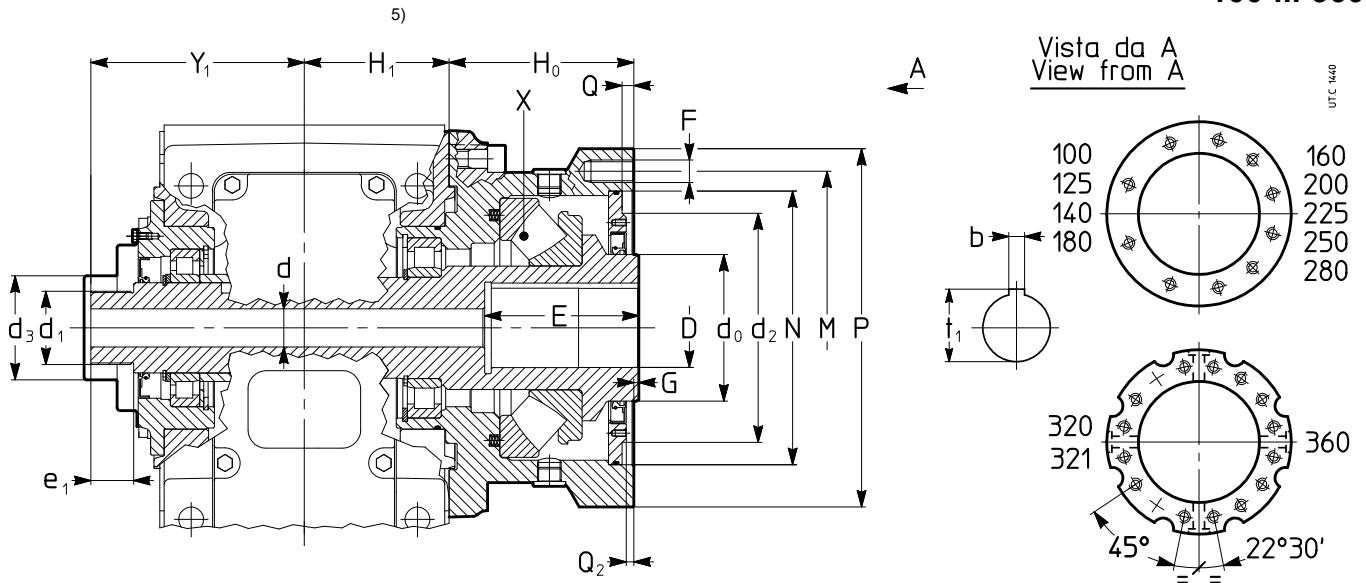

400 ... 451

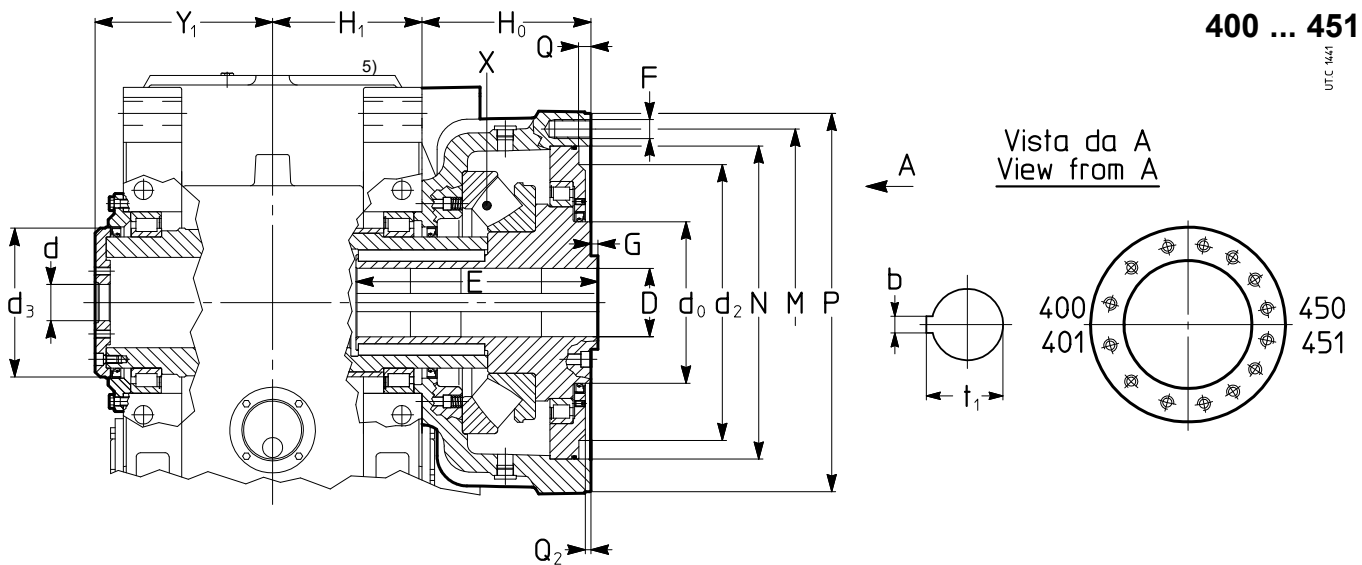

Size	Bearing		Design H																		
	X	C kN	D ¹⁾ ∅ H7	E ¹⁾⁴⁾ ∅	b	d	d ₀	d ₁	d ₂	d ₃	e ₁	F ²⁾³⁾	G	H ₀	M ²⁾ ∅	N ²⁾ ∅ H7	P ²⁾ ∅	Q	Q ₂	t ₁	Y ₁
100	294 12E	345	30	78	8	18	95	M35 ×1,5	95	59	25	M12 ⁸⁾	5	100	160	140	180	7	7	33,3	128
125	294 16E	575	40	103	12	27	110	M50 ×1,5	110	69	30	M14 ⁸⁾	1	120	208	180,5	240	8	8	43,3	148
140	294 18E	702	50	118	14	34	120	M50 ×1,5	180	74	30	M16 ⁸⁾	1	150	243	215	300	8	6,5	53,8	165
160	294 20E	863	60	133	18	34	120	M65 ×2	180	84	40	M16 ¹²⁾	1	150	243	215	300	8	6,5	64,4	191
180	294 22E	1 010	70	133	20	34	130	M65 ×2	200	93	40	M20 ⁸⁾	1	164	278	243	350	10	8,5	74,9	190
200	294 26E	1 380	80	158	22	43	160	M85 ×2	250	113	45	M20 ¹²⁾	1	182	318	283	380	10	5,5	85,4	212
225	294 30E	1 610	90	158	25	43	200	M85 ×2	272	113	45	M24 ¹²⁾	1	202	350	308	400	12	10,5	95,4	224
250	294 34E	2 020	100	188	28	43	200	M85 ×2	319	143	45	M24 ¹²⁾	1,5	222	400	358	450	12	10,5	106,4	251
280	294 38E	2 480	110	188	28	43	240	M90 ×2	344	143	45	M30 ¹²⁾	1,5	242	435	383	510	12	10,5	116,4	267
320, 321	294 48E	2 990	125	203	32	72	280	M120×2	361	173	45	M30 ¹²⁾	1,5	277	535	483	595	12	8	132,4	306
360	294 52E	3 510	140	203	36	72	280	M120×2	361	173	45	M30 ¹⁶⁾	1,5	277	535	483	595	12	8	148,4	325
4000, 4001	294 56E	4 310	135	393	36	72	320	-	563	295	-	M36 ¹⁶⁾	2	335	680	620	750	16	11,5	143,4	352
4500, 4501	294 64E	4 950	145	393	36	72	360	-	563	315	-	M36 ¹⁶⁾	2	335	680	620	750	16	11,5	153,4	352

See notes on previous page.

Technical features

Section contents

4.1	General	20
4.2	Thermal index of extruder support	20
4.3	Designs, dimensions, mounting positions, weight and oil quantity	21
4.4	Radial loads on high speed shaft end & gear reducer input face	21
4.5	Gearmotor input face	21
4.6	Lubrication	22
4.7	Plug position and dimension	23
4.8	Cooling systems	24
4.9	Plate heat exchanger with driven pump	26
4.10	Rear extraction of extruder shaft	30
4.11	Technical formulae	31
4.12	Gear selection form	32

4.1

General

For all technical data, service factor, sound level, thermal power max input speed into gear reducers / gearmotors, performances of gear reducers / gearmotors at different input speed we kindly ask you to refer to what stated into G catalog. To select the most correct service factor, as stated into G catalog, we recall your attention towards this additional table with coefficient to be used according to requested output speed of gear reducers / gearmotors.

These values have to be multiplied by the service factor indicated in G catalog.

n_2 min ⁻¹	
560 ÷ 355	1,25
355 ÷ 224	1,18
224 ÷ 140	1,12
140 ÷ 90	1,06
≤ 90	1,00

4.2

Thermal index of extruder support

Being now the lubrication in common between gear reducer and extruder support for all frame sizes, except from 400 to 451, the thermal index check of extruder support is no more so important as before, but it is always recommended to carry it on. In case this check is not satisfied, we will apply a cooling device.

Should it occur, contact us in order to decide the most suitable cooling device.

For a proper selection it's necessary to evaluate both the extruder support and the gear reducer thermal power as stated below.

Extruder support

It is necessary to evaluate the thermal power of the extruder support verifying that the thermal index stated in the table satisfies the following condition:

$$\text{thermal index} \geq \frac{n_2^{1,12} \cdot F_{ad} \cdot (D + d)}{40\,000\,000}$$

where:

n_2 [min⁻¹] speed of low speed shaft;

D, d [mm] external and internal diameters of thrust bearing (see following table);

F_{ad} [N] axial dynamic force.

T _{amb.} [°C]	Thermal index																				
	design N size								design H size												
	bearing 294... D + d								bearing 294... D + d												
	140	160	180	200	225	250	280	320, 321	100	125	140	160	180	200	225	250	280	320, 321	360	400, 401	450, 451
...17E 265	...17E 265	...20E 310	...22E 340	...26E 400	...30E 450	...34E 510	...40E 600	...12E 190	...16E 250	...18E 280	...20E 310	...22E 340	...26E 400	...30E 450	...34E 510	...38E 570	...48E 680	...52E 740	...56E 800	...64E 900	
10	300	300	400	500	630	950	950	1 500	150	236	355	355	450	560	710	950	1 060	1 500	1 500	2 120	2 120
20	265	265	355	450	560	850	850	1 320	132	212	315	315	400	500	630	850	950	1 320	1 320	1 900	1 900
30	236	236	315	400	500	750	750	1 180	118	190	280	280	355	450	560	750	850	1 180	1 180	1 700	1 700
40	200	200	265	335	425	630	630	1 000	100	160	236	236	300	375	475	630	710	1 000	1 000	1 400	1 400
50	160	160	212	265	335	500	500	800	80	125	190	190	236	300	375	500	560	800	800	1 120	1 120

Whenever the verification is not satisfactory use **water cooling, with coil** (consult us) or **independent cooling unit** with oil/water heat exchanger (see ch. 12).

On request, the product is supplied with the **calculation of thrust bearing life**, according to ISO 281, considering the load conditions (F axial dynamic, n_2) of Customer application.

Designs, dimensions, mounting positions, weights and oil quantities

Refer to G catalog, ch. 8, 10, 12 and 14.
Refer to H catalog, ch. 8 and 10 for sizes 4000 ... 4501.

Radial loads $Fr1$ [N] on high speed shaft end & gear reducer input face

Refer to G catalog, ch. 16.1.
Refer to H catalog, ch. 11.1.

Gearmotor input face

The gearmotor input face has a motor mounting flange (see in G catalog page 48 for maximum allowable bending moment values M_{bmax}) including bolts for standardized motor and a hollow high speed shaft provided for $d \geq 38$, with **axial cuts** and **hub clamp**.

The **keying system** with **key** and **hub clamp** ensures a high connection stability, easier installing and removal (absence of fretting corrosion), best alignment and compactness.



Important: always verify that

$$M_b \leq M_{bmax}$$

where:

$$M_b = G \cdot (X + HF) / 1000 \text{ [N m]}$$

G [N] motor weight

X [mm] distance between motor centre of gravity and flange surface

HF [mm] given in the table

Hollow high speed shaft with keyway, hub clamp (dynamically balanced) and axial cuts.

Refer to G catalog where M_b is already checked (see table on page 48).

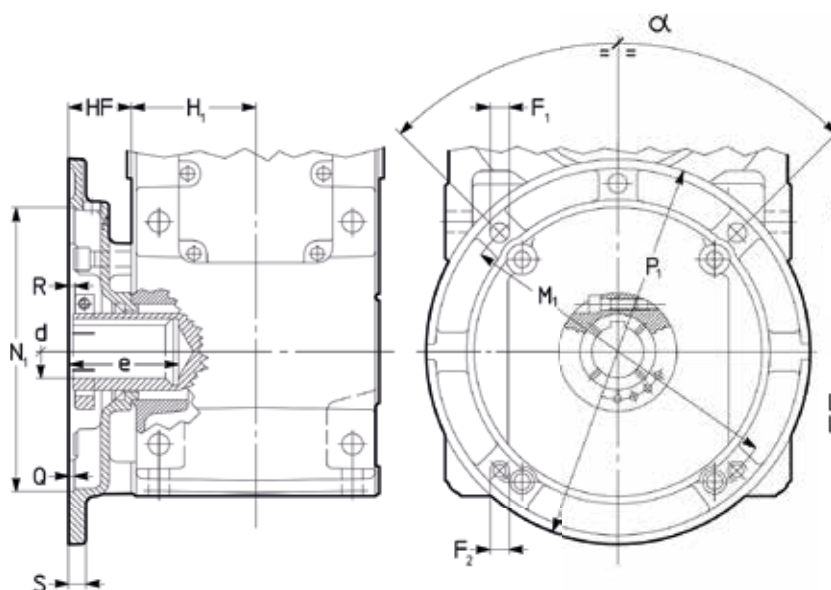

Hole		Hub clamb		Parallel key			Keyway				
d ¹⁾	e	Screw	M _S ³⁾	b	x	h	x	l*	b	t	t ₁
∅		2)	N m								±0,1
24	53	—	—	8	x	7	x	40	8	4	27,3
28	63	—	—	8	x	7	x	50	8	4	31,3
38	83	M8	25	10	x	8 ⁴⁾	x	70	10	5	40,2 ⁶⁾
42	113	M12	143	12	x	8	x	90	12	5	45,3
48	113	M12	143	14	x	9	x	90	14	5,5	51,8
55	113	M12	143	16	x	10	x	90	16	6	59,3
60	143	M12	143	18	x	11	x	125	18	7	64,4
65	143	M12	143	18	x	11	x	125	18	7	69,4
75	143	M12	143	20	x	12 ⁵⁾	x	125	20	7,5	79,9 ⁷⁾
80	173	M14	135	22	x	14	x	125	22	9	85,4

* Recommended length.

- 1) Tolerance: G6 for $d \leq 28$, F6 for $d \geq 38$.
- 2) UNI 5931-84 class 8.8 (12.9 for M12).
- 3) Tightening torque.
- 4) 10x7x70 for sizes. 100, 125 and 140.
- 5) 20x11x125 for sizes. 200 and 225.
- 6) Value **not** to standard.
- 7) For sizes 200 and 225 dimension $t_1 = 78,8$ (value **not** standard).

Hole	Flange	Gear reducer size																																										
		100					125					140					160, 180					200, 225					250, 280 ²⁾					320 ... 360 ²⁾												
d ¹⁾	P ₁	M ₁	N ₁	Q	F ₁	F ₂	R	S	HF	F ₁	F ₂	R	S	HF	F ₁	F ₂	R	S	HF	F ₁	F ₂	R	S	HF	F ₁	F ₂	R	S	HF	F ₁	F ₂	R	S	HF										
∅	∅	∅	∅ H7	∅	∅	∅	∅	∅	∅	∅	∅	∅	∅	∅	∅	∅	∅	∅	∅	∅	∅	∅	∅	∅	∅	∅	∅	∅	∅	∅	∅	∅	∅	∅	∅	∅								
24	200	165	130	4	11,5	M10	—	14	45																																			
28	250	215	180	5	14	14	—	14	45	14	M12	—	16	55																														
38	250	215	180	5	14	14	15	16	65	14	M12	15	16	55	12	M12	14	16	55																									
	300	265	230	5	14	14	15	16	65	14	14	18,5	16	60,5	M12	M12	15	16	55																									
42	350	300	250	6						18	18	20	18	75	M16	18	20	18	75	M16	M16	20	18	75	M14	M14	10	18	67															
48	350	300	250	6						18	18	20	18	75	M16	18	20	18	75	M16	M16	20	18	75	M14	M14	10	18	67															
55	400	350	300	6											M16	18	8	18	65					M16	M16	8	18	67	M16	M16	6,5	18	65											
60	400	350	300	6											M16	M16	34,5	20	97	M16	M16	32	20	95																				
	450	400	350	6											18	18	35	20	95	18	18	35,5	20	97	18	18	34,5	20	95															
65	400	350	300	6											M16	M16	22	20	97	M16	M16	22,5	20	95	M16	M16	17	20	85															
	450	400	350	6											18	18	26	20	97	18	18	23,5	20	95	M16	M16	17	20	85															
	550	500	450	6											18	18	22	22	97	18	18	23,5	22	95																				
75	450	400	350	6											18	18	26	20	97	18	18	23,5	20	95	M16	M16	17	20	85															
	550	500	450	6											18	18	22	22	97	18	18	23,5	22	95	18	18	23,5	22	95	18	18	23,5	22	95	18	18	23,5	22	95					
80	660	600	550	7																				22	22	27	25	115	22	22	28	25	115											

Note: $\alpha = 90$ for $P_1 \leq 400$; $\alpha = 45$ for $P_1 \geq 450$.

- 1) Tolerance: G6 for $d \leq 28$, F6 for $d \geq 38$.
- 2) For EN4U and EH4U consult us.

4.6

Lubrication

About plug positions and oil quantity, according to different mounting positions, see cat. G, ch. 8, 10, 12 and 14.
About frame sizes 4000 ... 4501, see cat. H, ch. 8 and 10.

For a complete motor options description see cat. TX motors of series HB.

Plug position and dimension

The scheme show plug types and positions for standard gear reducers. For non-standard design, consult us.
For sizes. 4000 ... 4501, consult us.

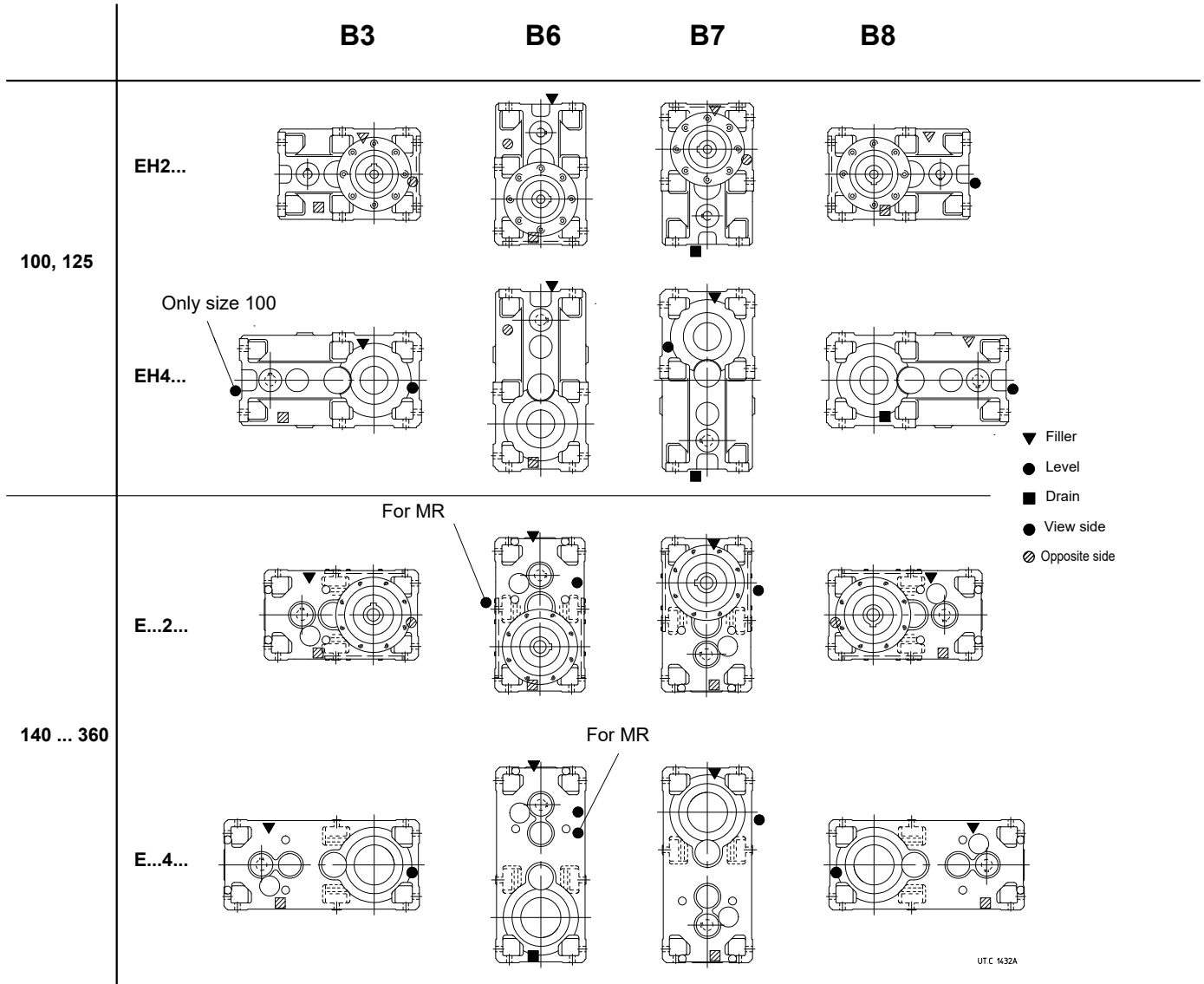

Threaded holes	Size					
	100	125	140	160 ... 225	250 ... 280	320 ... 360
Gear reducer	1/2" G	1/2" G	1/2" G	3/4" G	3/4" G	1" G
Extruder support	M16×1,5	M16×1,5	1/2" G	1/2" G	3/4" G	3/4" G

4.8

Cooling systems

4.8.1 Water cooling by coil (sizes 125 ... 360)

Gear reducers and gearmotors sizes 125 ... 360, excluding ICI train of gears and mounting positions V... with groove side towards the bottom, can be supplied with copper alloy coil for water cooling.

On request, available also stainless steel coil (AISI 316) or cupro-nickel; consult us.

Cooling water specifications:

- be not too hard ≤ 12 °F (French degrees) ;
- max temperature 20 °C;
- capacity 10 ÷ 20 dm³/min;
- pressure 0,2 ÷ 0,4 MPa (2 ÷ 4 bar).

A smooth metallic pipe (with external diameter **d** stated on table) is sufficient for the connection.

The load loss in the coil, according to the water flow and pressure, is of 0,6 ÷ 0,8 bar for diameter Ø d16 and 0,8 ÷ 1 bar for diameter Ød 12.

On request **thermostatic valve** which, automatically and without auxiliary supply need, permits water circulation when gear reducer oil reaches the set temperature; the valve sensor is equipped with immersion bulb. Mounting and setting, adjustable within 50 ÷ 90 °C, are Buyer's responsibility.

For ambient temperature lower than 0 °C consult us.

Supplementary description when ordering by **designation: water cooling by coil or water cooling by coil and thermostatic valve.**

Size	A	B	d	M [Nm]
125 ... 180	40	40	10	30
200 ... 280	50	40	12	30
320 ... 360	60	45	16	35

1) Values valid for B3 mounting position and U ... A design.
For other mounting positions and/or designs: consult us.

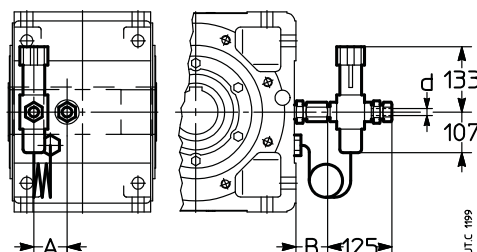

4.8.2 Water cooling

Gear reducers and gearmotors can be supplied with lubrication oil cooling by water.

Sizes 140 ... 360: inner and **removable** aluminium finned heat exchanger (for easier maintenance operations) mounted onto the gear reducer inspection cover.

Sizes 4000 ... 4501: **fixed** copper coil mounted onto the gear reducer housing.

Inner heat exchanger mounted onto gear reducer inspection cover.

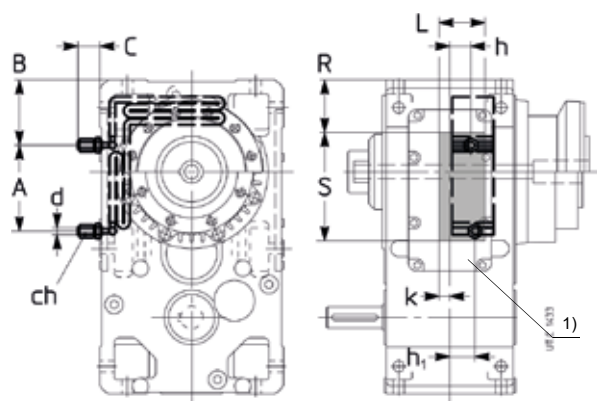

140 ... 360

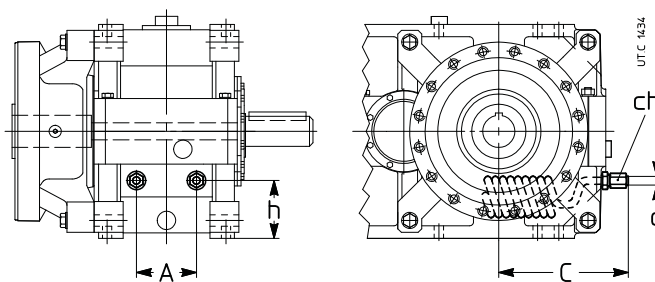

4000 ... 4501

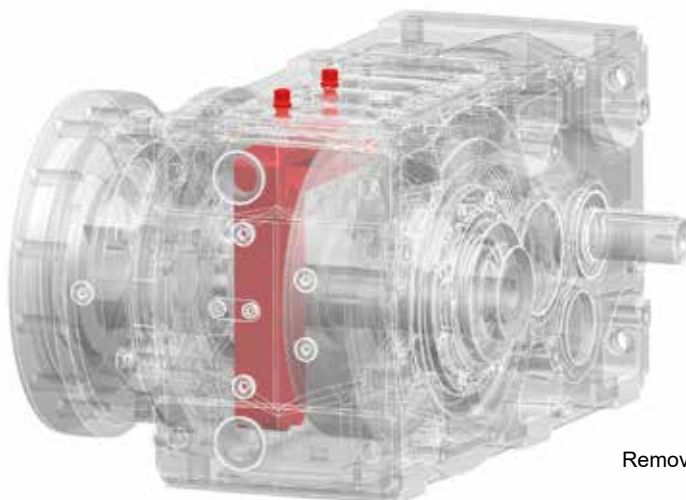

Removable inner heat exchanger

4.8.3 Independent cooling unit

An oil cooling system when coil cooling is not sufficient anymore (for thermal power verification see ch. 4). Consisting of oil/water heat exchanger, motor pump, analogic manometer, low pressure switch and remote controller of oil temperature (composed by a Pt100 probe and by a 2 set point signalling device) allowing the pump to start. Connections realised by a flexible pipes (type SAE 100 R1, maximum length 4 m) between gear reducer and cooling unit and the mounting of a 2 set point signalling device (separately supplied for the mounting on rail DIN EN 50022) are Buyer's responsibility. On request, several accessories are at disposal (thermometers, flowswitches, filters, etc., separately supplied; assembly is at Buyer's responsibility) in order to satisfy all functionality and safety needs.

About thermal factors, refer to G catalog.

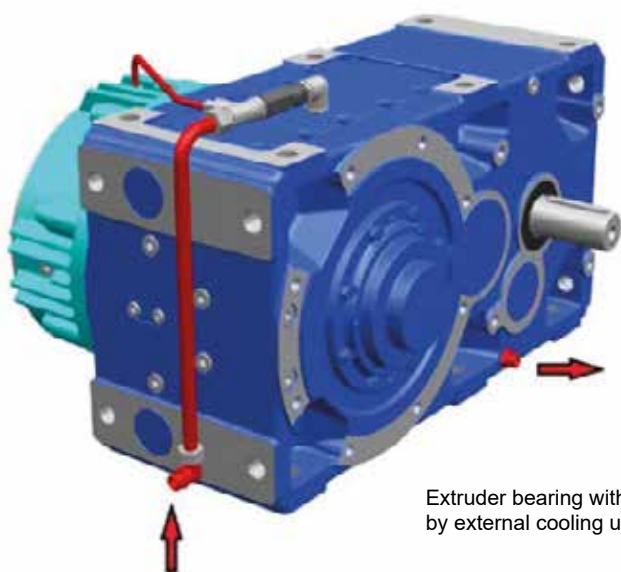

Extruder bearing with forced lubrication by external cooling unit

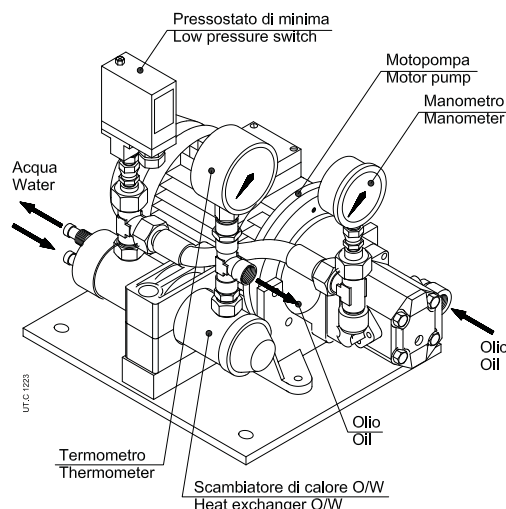

4.9

Plate heat exchanger with driven pump



For all other available accessories, refer to G catalog.

The system made of:

- Oil/water heat exchanger with stainless steel plates, brazed plates vacuum with copper ally, heat exchanger installed on board reducer.
- Volumetric pump
- Thermometer, pressure gauge, pressure switch
- Oil temperature probe Pt100

Accessories on request:

- Bi-metal type thermostat
- Flow switch
- Filter

The driven pump shall be mounted in place of the backstop device.

It is not possible to mount the backstop device in the same time with the driven pump.

- The maximum operating pressure of the exchanger is 30 bar.
- The operating temperature of the heat exchanger is between 0 °C and + 125 °C.
- The maximum difference between the temperatures of the two fluids is 100 °C.
- Nominal water flow: 10 - 20 dm³/min
- Maximum water flow: 50 dm³/min

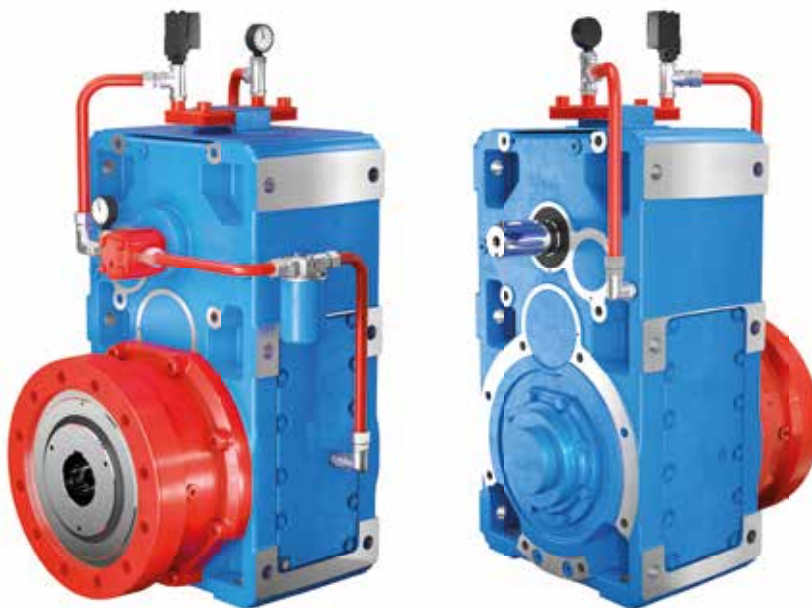
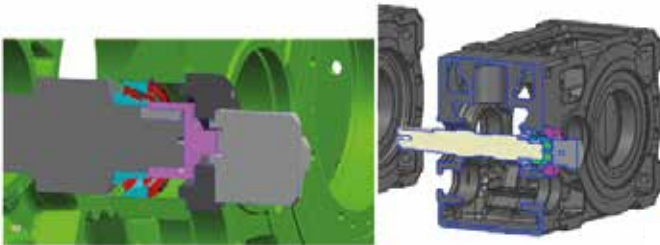

Outside water cooling by pump driven by gear reducer shaft and plate heat exchanger

When the machine on which it is installed is running at rated speed, it is necessary to check the exchanger's flow rate. This can be done easily by controlling its thermal jump that should not be too low (too high flow rate), nor too high (low flow rate). It is a good rule to consider a cooling water thermal jump of 10 °C when the inlet water temperature is 20 °C and a thermal jump of 5 °C with higher water temperatures.

Maximum water flow rate is 50 litres/min.

To obtain the maximum efficiency of the exchanger, the water flow must be counter-current with the oil flow.

Additional description when ordering by designation:

oil-water cooling unit UR O/W ..., possibly integrated, when required by the application, with description: "Forced lubrication ..." and the statement of bearings and/or gear pairs to be lubricated. For dimensions, accessories and further technical details, see specific literature.

For the heat exchanger power required by the independent cooling unit:

$$P_s \geq (P_1 - P_{t_N} \cdot f_{t_1} \cdot f_{t_2} \cdot f_{t_3} \cdot f_{t_4} \cdot f_{t_5}) \cdot (1 - \eta) \cdot K_1$$

where:

- P_s nominal power of unit [kW], i.e. the power dissipable with hot oil at approx. 80 °C and cooling air at 40 °C (O/A) or cooling water at 20 °C (O/W) with stated capacity (see next table);
- P_1 power at gear reducer input [kW] (consider the power installed when being uncertain about the power absorbed).
- P_{t_N} nominal thermal power of gear reducer [kW] (see ch. 4 of G and H cat.);
- f_{t_1} thermal factor according to input speed (see ch. 4 of G and H cat.);
- f_{t_2} thermal factor according to ambient temperature (see ch. 4 of G and H cat.);
- f_{t_3} thermal factor according to mounting position (see ch. 4 of G and H cat.);
- f_{t_4} thermal factor according to altitude (see ch. 4); for UR O/A derate also the exchanger power: multiply P_s by 0,85 (for 1 000 ÷ 2 500 m a.s.l.) or by 0,71 (for 2 500 ÷ 5 000 m a.s.l.);
- f_{t_5} thermal factor according to air speed on the housing (see ch. 4 of G and H cat.);
- η gear reducer efficiency (see ch. 6 of G and H cat.);
- $K_1 = 1,18$ takes into account the decrease of the exchanger efficiency due to dirt on the external surface.

		Technical data			Exchanger	
		Ps [kW]	n [min ⁻¹]	Pump Flow rate [dm ³ /min]		
UR O/W P	BA WA	5	1000	10	M18-10	
		7	1200	13		
		8	1500	16		
		10	1800	19		
		7	1000	14		
		9	1200	17		
		11	1500	21		
		14	1800	25		
		22	1000	16		
		27	1200	18		
	34	1500	21	M18-10		
	41	1800	24			
	BI	7	1000		14	M18-10
		9	1200		17	
		11	1500	21		
		14	1800	25		
		8	1000	16		
		10	1200	19		
		13	1500	24		
		15	1800	28		
13		1000	16	M18-20		
14		1200	19			
16	1500	24				
19	1800	28				

For all other available accessories, refer to G catalog.

At nominal speed, the pump flow rate in dm³/min must always be less than 1,2 times the amount of oil in the gear reducer:
pump flow rate [dm³/min] ≤ 1,2 × quantity of oil in gear reducer [dm³]

Pump directions of rotation

BA black arrow direction of rotation
WA white arrow direction of rotation
BI bidirectional direction of rotation

4.10

Rear extraction of extruder shaft

Note that this particular kind of extraction is only possible with the H extruder support and with this particular design the lubrication between gear reducer and extruder support will be separated and no more in common. For that it becomes very important to check the thermal capacity of extruder support.

Refer to table related to thermal index.

Design HA: fitting extruder screw using key

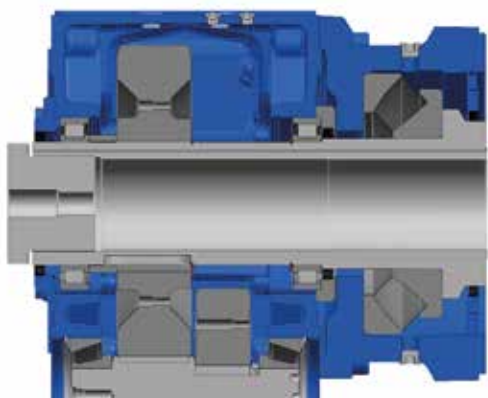
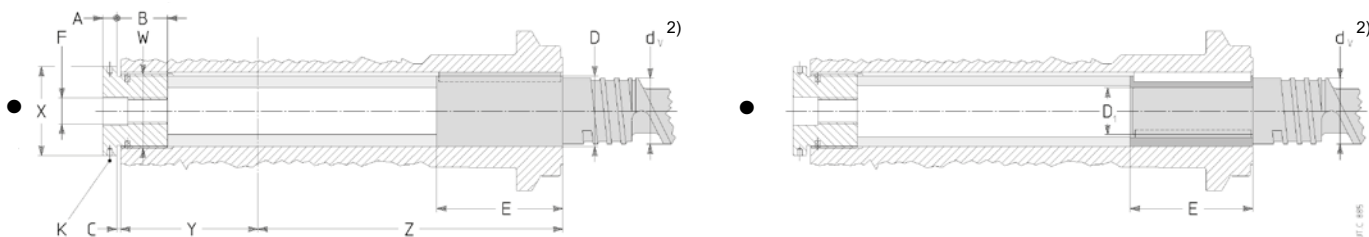

HA design: screw (with keyway)
extraction on the opposite side to
extruder

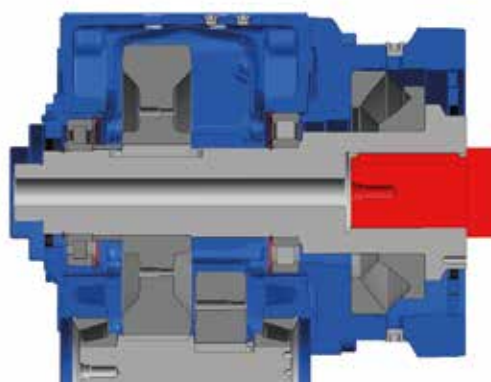

Screw shoulder on front face

2)

Design HB: fitting extruder screw using spline profile

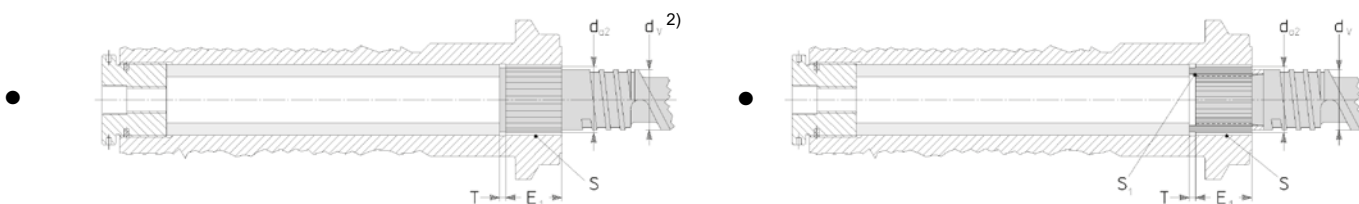

• Reference groove side (see cat. G).

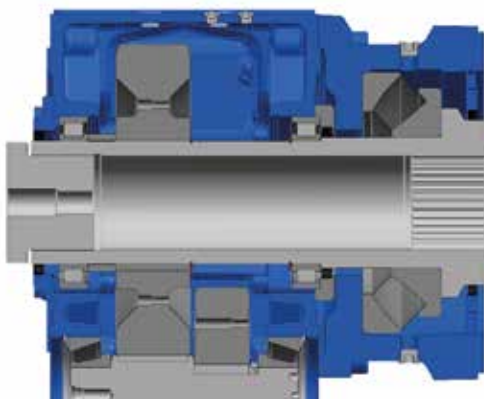

HB design: screw (spline) extraction on the opposite side to extruder

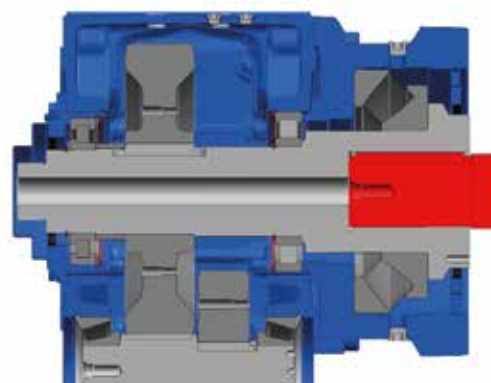

Ground bottom for screw support

Gear reducer size	Threaded bush						Hollow shaft/extruder screw spigot													
	A	B	C	F	K ¹⁾ ∅	X	W ∅	D ²⁾ ∅ max H7	E max	D ₁ ∅ max H7	E ₁	Y	L	L ₁ max	S max DIN 5480	d _{a2} ²⁾ ∅	S ₁ ³⁾ max DIN 5480	T	V ₁ H7	Z
125	15	38	3	M 24 × 2	6 × 8	68	M 55 × 1,5	52	105	35	40	110	253,5	13	50 × 2	46	35 × 2	6	52	224,5
140	15	42	3	M 24 × 2	6 × 8	78	M 62 × 1,5	60	105	40	48	125	285,5	15	60 × 2	52	40 × 2	6	60	254,5
160	18	48	3	M 24 × 2	6 × 8	88	M 70 × 1,5	67	130	45	52	136	312,5	17	65 × 3	59	45 × 2	6	67	279,5
180	18	53	3	M 24 × 2	6 × 8	100	M 80 × 1,5	75	130	52	60	150	327,5	19	75 × 3	69	55 × 2	6	75	293,5
200	24	64	4	M 36 × 3	8 × 11	118	M 95 × 2	90	150	63	72	167	368	22	90 × 3	84	65 × 3	8	90	341
225	24	74	4	M 36 × 3	8 × 11	140	M 110 × 2	105	180	75	85	180	378	26	105 × 4	97	75 × 3	8	105	361
250	24	86	6	M 36 × 3	8 × 11	155	M 125 × 3	120	210	85	95	206	438,5	30	120 × 4	112	90 × 3	11	120	418,5
280	30	96	6	M 36 × 3	10 × 14	175	M 140 × 3	135	230	95	108	222	451,5	34	135 × 4	127	100 × 3	11	135	438,5
320, 321	30	108	8	M 56 × 4	10 × 14	190	M 155 × 4	150	260	110	120	254	540	38	150 × 5	140	110 × 4	13,5	150	519,5
360	30	126	8	M 56 × 4	10 × 14	225	M 185 × 4	170	300	125	150	273	511	45	180 × 5	170	135 × 5	13,5	180	519,5

1) N. 4 holes for sizes. 125 ... 250, n. 6 holes for sizes. 280 ... 360.

2) d_i dimensions must not be higher than (0,94 ÷ 0,97) · D or (0,94 ÷ 0,97) · d_{2a}.

* Grey objects are on Buyer's care.

Frame size	With Technical System units	With SI units
starting or stopping time as a function of an acceleration or deceleration, of a starting or braking torque	$t = \frac{v}{a} \text{ [s]}$ $t = \frac{Gd^2 \cdot n}{375 \cdot M} \text{ [s]}$	$t = \frac{J \cdot \omega}{M} \text{ [s]}$
velocity in rotary motion	$v = \frac{\pi \cdot d \cdot n}{60} = \frac{d \cdot n}{19,1} \text{ [m/s]}$	$v = \omega \cdot r \text{ [m/s]}$
angular velocity	$n = \frac{60 \cdot v}{\pi \cdot d} = \frac{19,1 \cdot v}{d} \text{ [min}^{-1}\text{]}$	$\omega = \frac{v}{r} \text{ [rad/s]}$
acceleration or deceleration as a function of starting or stopping time		$a = \frac{v}{t} \text{ [m/s}^2\text{]}$
angular acceleration or deceleration as a function of a starting or stopping time, of a starting or braking torque	$\alpha = \frac{n}{9,55 \cdot t} \text{ [rad/s}^2\text{]}$ $\alpha = \frac{39,2 \cdot M}{Gd^2} \text{ [rad/s}^2\text{]}$	$\alpha = \frac{\omega}{t} \text{ [rad/s}^2\text{]}$ $\alpha = \frac{M}{J} \text{ [rad/s}^2\text{]}$
starting or stopping distance as a function of an acceleration or deceleration, of a final or initial velocity		$s = \frac{a \cdot t^2}{2} \text{ [m]}$ $s = \frac{v \cdot t}{2} \text{ [m]}$ $w = \frac{\alpha \cdot t^2}{2} \text{ [rad]}$
starting or stopping angle as a function of an angular acceleration or deceleration, of a final or initial angular velocity	$\varphi = \frac{n \cdot t}{19,1} \text{ [rad]}$	$\varphi = \frac{\omega \cdot t}{2} \text{ [rad]}$
mass	$m = \frac{G}{g} \left[\frac{\text{kgf s}^2}{\text{m}} \right]$	m è l'unità di massa [kg]
weight (weight force)	G è l'unità di peso (forza peso) [kgf]	$G = m \cdot g \text{ [N]}$
force in vertical (lifting), horizontal, inclined motion of translation (μ = coefficient of friction; φ = angle of inclination)	$F = G \text{ [kgf]}$ $F = \mu \cdot G \text{ [kgf]}$ $F = G (\mu \cdot \cos \varphi + \sin \varphi) \text{ [kgf]}$	$F = m \cdot g \text{ [N]}$ $F = \mu \cdot m \cdot g \text{ [N]}$ $F = m \cdot g (\mu \cdot \cos \varphi + \sin \varphi) \text{ [N]}$
dynamic moment Gd^2 , moment of inertia J due to a motion of translation (numerically $J = \frac{Gd^2}{4}$)	$Gd^2 = \frac{365 \cdot G \cdot v^2}{n^2} \text{ [kgf m}^2\text{]}$	$J = \frac{m \cdot v^2}{\omega^2} \text{ [kg m}^2\text{]}$
torque as a function of a force, of a dynamic moment or of a moment of inertia, of a power	$M = \frac{F \cdot d}{2} \text{ [kgf m]}$ $M = \frac{Gd^2 \cdot n}{375 \cdot t} \text{ [kgf m]}$ $M = \frac{716 \cdot P}{n} \text{ [kgf m]}$	$M = F \cdot r \text{ [N m]}$ $M = \frac{J \cdot \omega}{t} \text{ [N m]}$ $M = \frac{P}{\omega} \text{ [N m]}$
work, energy in motion of translation, in rotary motion	$W = \frac{G \cdot v^2}{19,6} \text{ [kgf m]}$ $W = \frac{Gd^2 \cdot n^2}{7160} \text{ [kgf m]}$	$W = \frac{m \cdot v^2}{2} \text{ [J]}$ $W = \frac{J \cdot \omega^2}{2} \text{ [J]}$
power in motion of translation, in rotary motion	$P = \frac{F \cdot v}{75} \text{ [CV]}$ $P = \frac{M \cdot n}{716} \text{ [CV]}$	$P = F \cdot v \text{ [W]}$ $P = M \cdot \omega \text{ [W]}$
power available at the shaft of a single-phase motor ($\cos \varphi$ = power factor)	$P = \frac{U \cdot I \cdot \eta \cdot \cos \varphi}{736} \text{ [CV]}$	$P = U \cdot I \cdot \eta \cdot \cos \varphi \text{ [W]}$
power available at the shaft of a three-phase motor	$P = \frac{U \cdot I \cdot \eta \cdot \cos \varphi}{425} \text{ [CV]}$	$P = 1,73 \cdot U \cdot I \cdot \eta \cdot \cos \varphi \text{ [W]}$

Note. Acceleration or deceleration are understood constant; motion of translation and rotary motion are understood rectilinear and circular respectively.

4.12

Gear selection form

Date	Agent
Customer name	
Customer reference	
Annual purchased quantity	

SCREW

Screw diameter DS [mm]			
Working pressure [bar]			
Shank (include drawing if unusual)	Cylindrical (standard)	diameter [mm] :	
	Splined		
Shank length E [mm]			
Contact area type (see attached drawing)	OPTION A		OPTION B

MOTOR

Nominal power kW]	
Nominal speed [min-1]	
Ambient Temperature [°C]	
Max speed (constant power) [min-1]	
Motor position (support side "U" / opposite side "Z")	

CONNECTION WITH GEARBOX

Coupling	(no other information required)	
gearmotor (data required also for bell housing & coupling)	Shaft diameter [mm]	
	Shaft length [mm]	
	Flange diameter [mm]	
	Weight [kg]	
	Total length (without shaft) [mm]	
Belts & pulleys	belts type and number	
	motor pulley diameter [mm]	
	gear reducer pulley diameter [mm]	

GEAR REDUCER

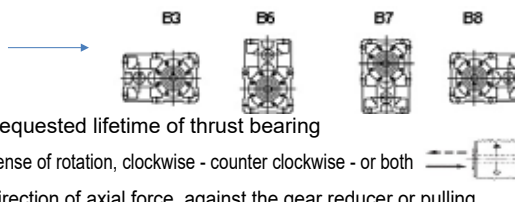
Helical		Bevel helical	
Transmission ratio			
Mounting position			
Requested Torque by the application [Nm]			
Lh = [h]			
Direction		Requested lifetime of thrust bearing	
Direction		Sense of rotation, clockwise - counter clockwise - or both	
		Direction of axial force, against the gear reducer or pulling	

NON-STANDARD FEATURES (please provide us with a drawing)

Extruder support flange (see attached drawing)	P=	M=	N=	G=
Fixing threaded holes	No.	M....X.....		
Screw extraction design				
Others				

OPTION A

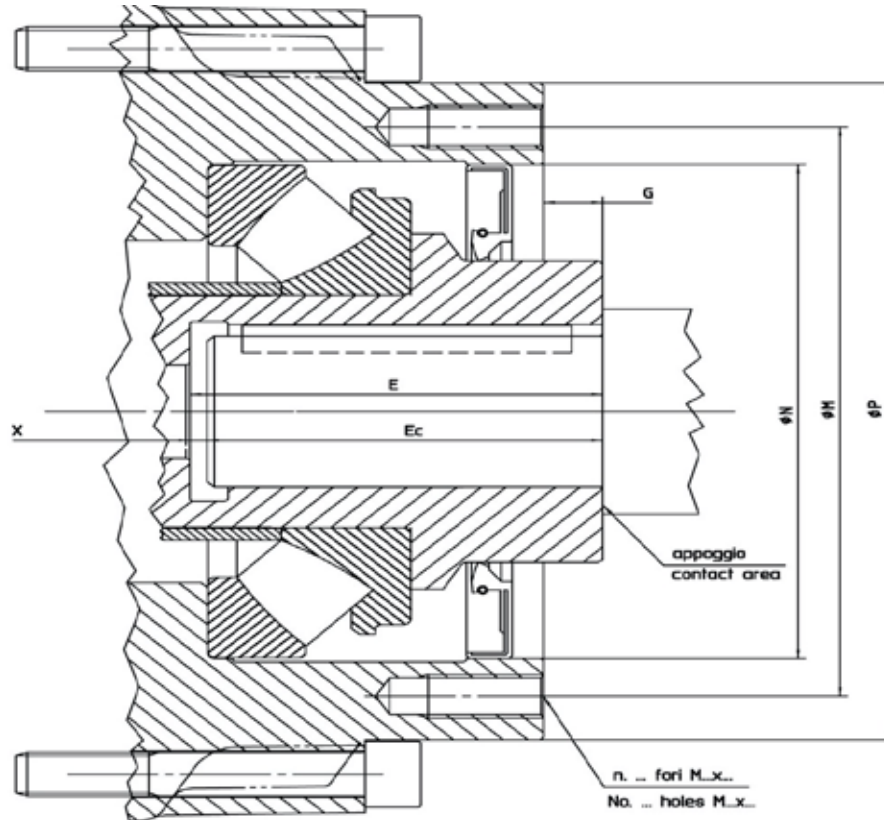

OPTION B

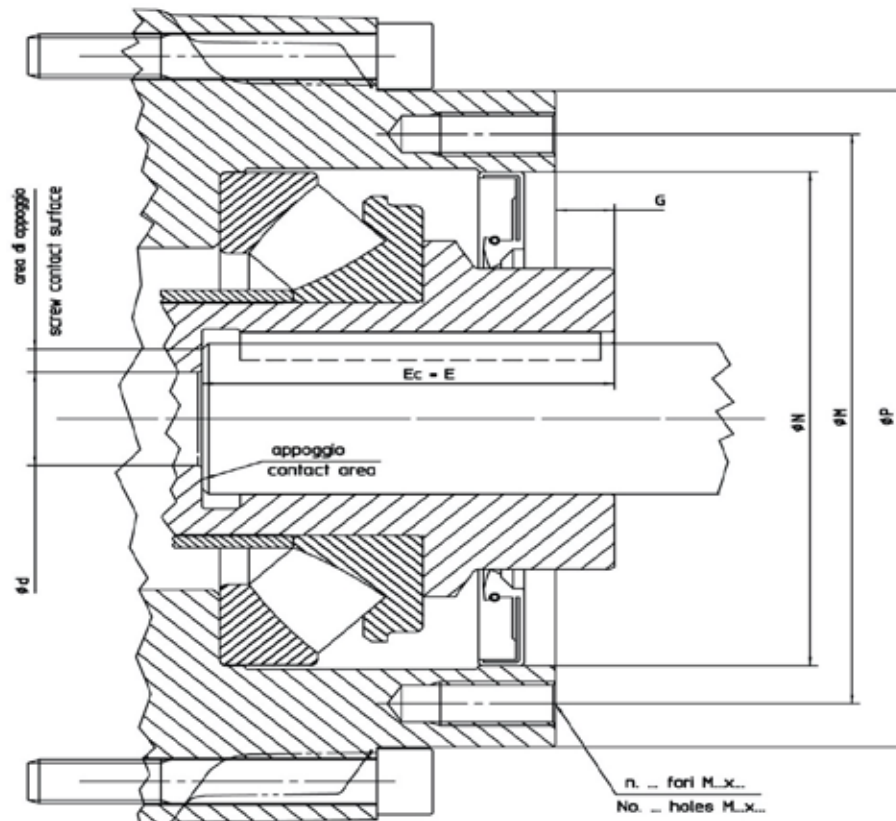

Notes

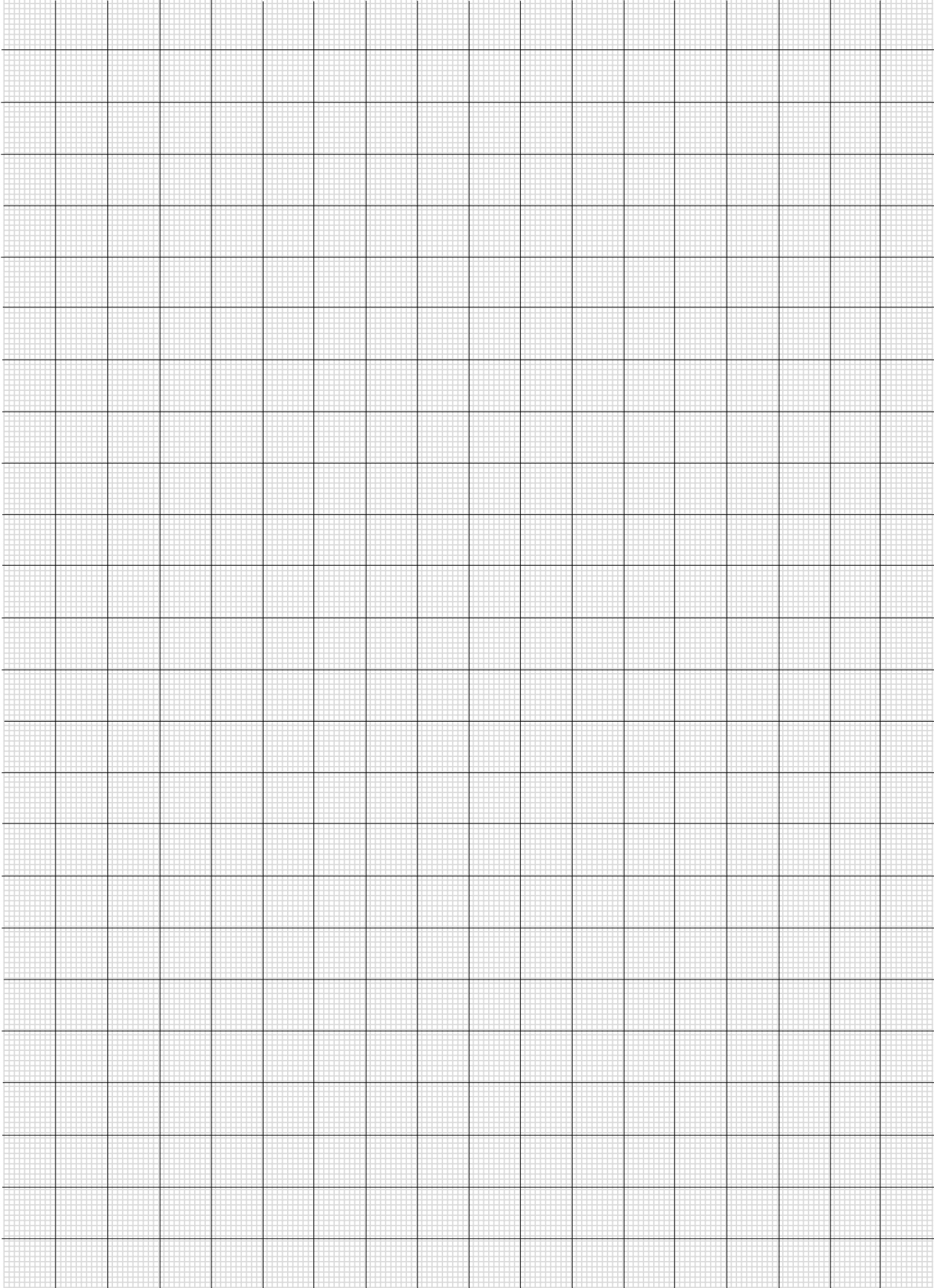

Notes

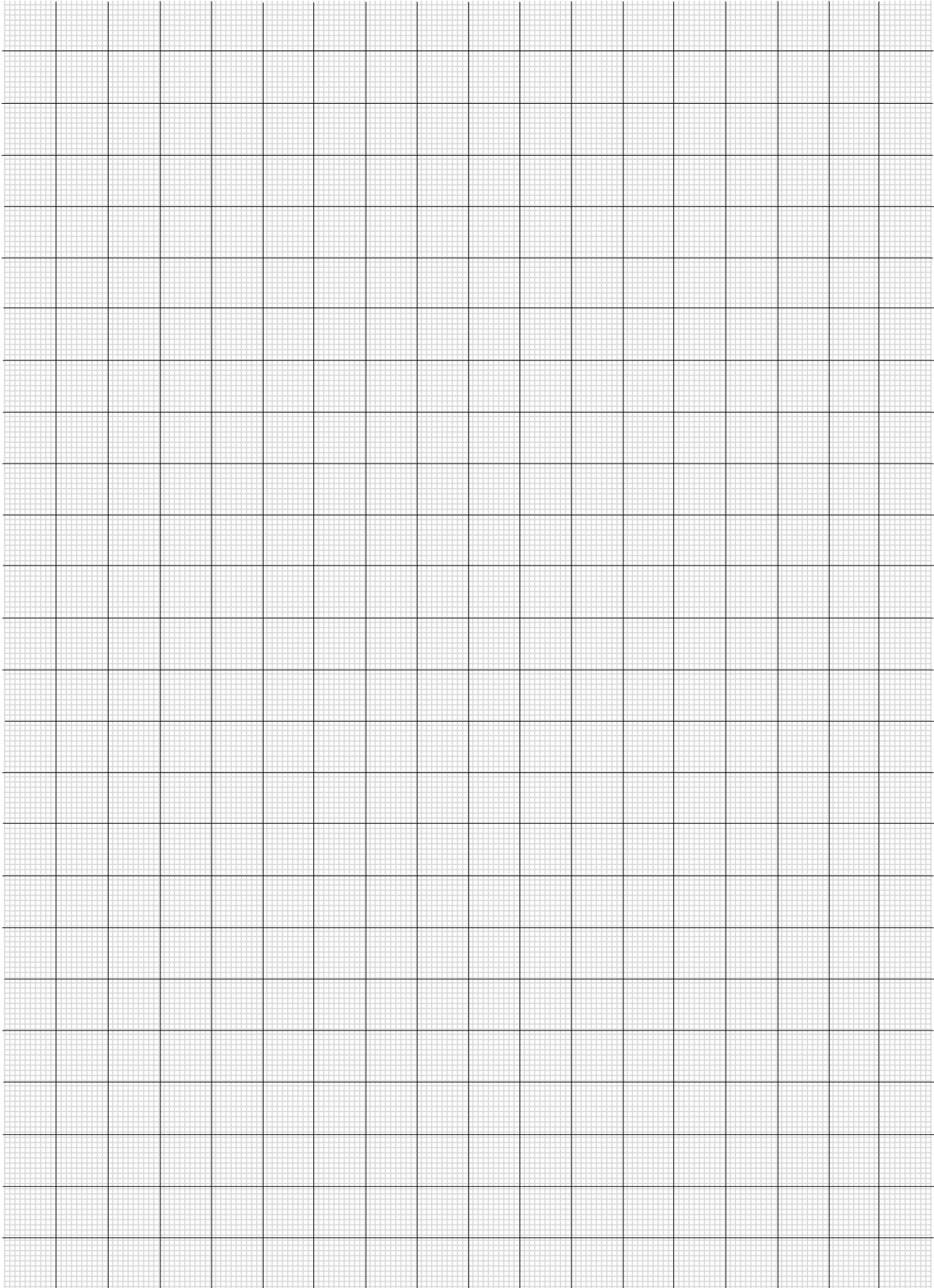

Notes

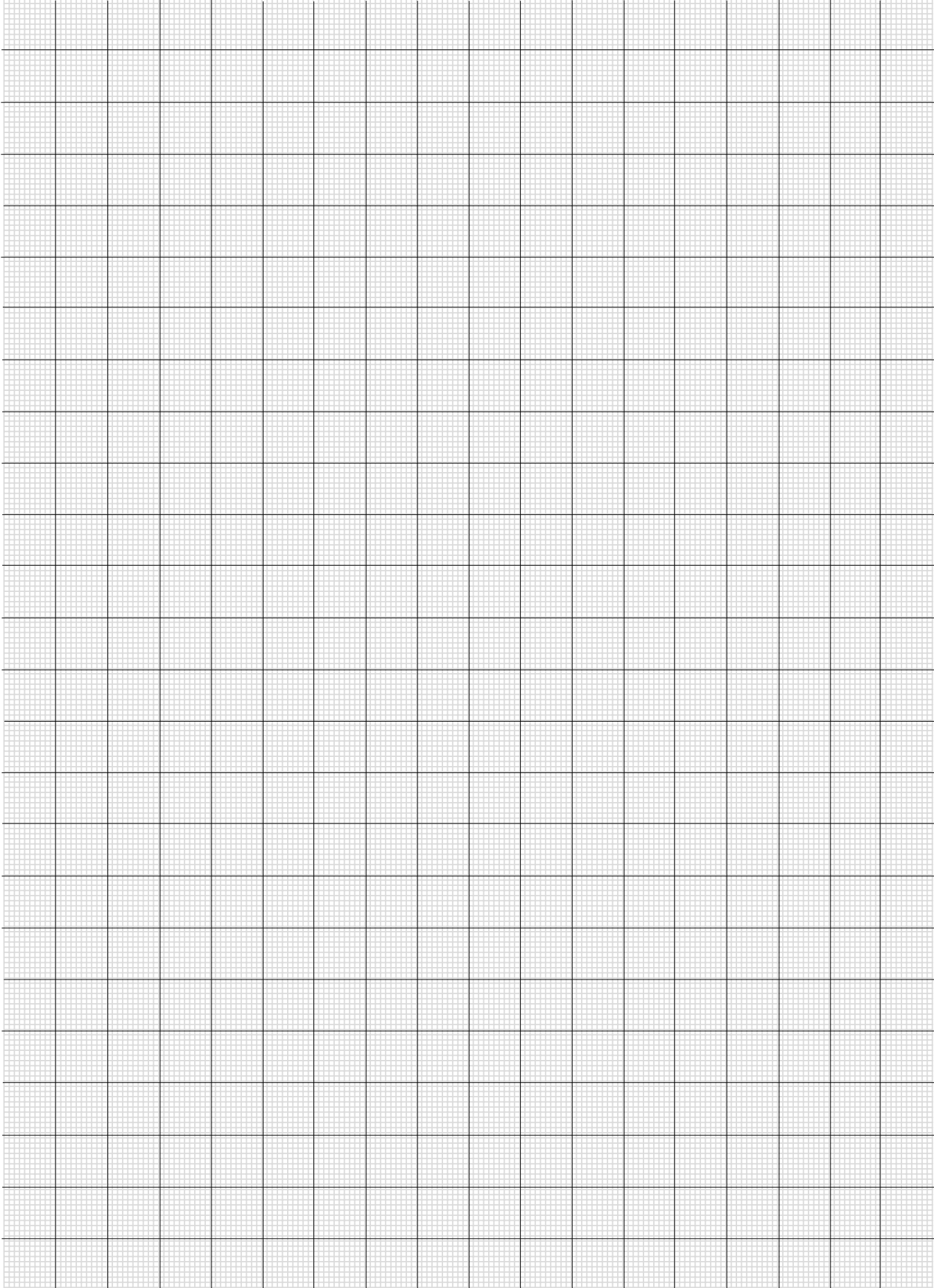



Solutions for
an evolving
industry

HEADQUARTERS

Rossi S.p.A.
Via Emilia Ovest 915/A
41123 Modena - Italy

info@rossi.com
www.rossi.com

© Rossi S.p.A. Rossi reserves the right to make any modification whenever to this publication contents. The information given in this document only contains general descriptions and/or performance features which may not always specifically reflect those described.

2632.BRO.EXT-21.09-0-EN