



# Recycling & Water Treatment

[rossi.com](http://rossi.com)





# Recycling & Water treatment

Recycling & Water treatment is a spearhead sector not only for the world economy, but for society as a whole. Our skills in process engineering encompass all the aspects of separation in the water sector, including water treatment and the disposal and recycling of solid waste.

Thanks to a vast range of gear reducers, gearmotors, and accessories you will keep water treatment facilities up and running without downtime. We offer flexible solutions to reduce energy consumption, ensuring greater efficiency.



Recycling & Water treatment



# Recycling

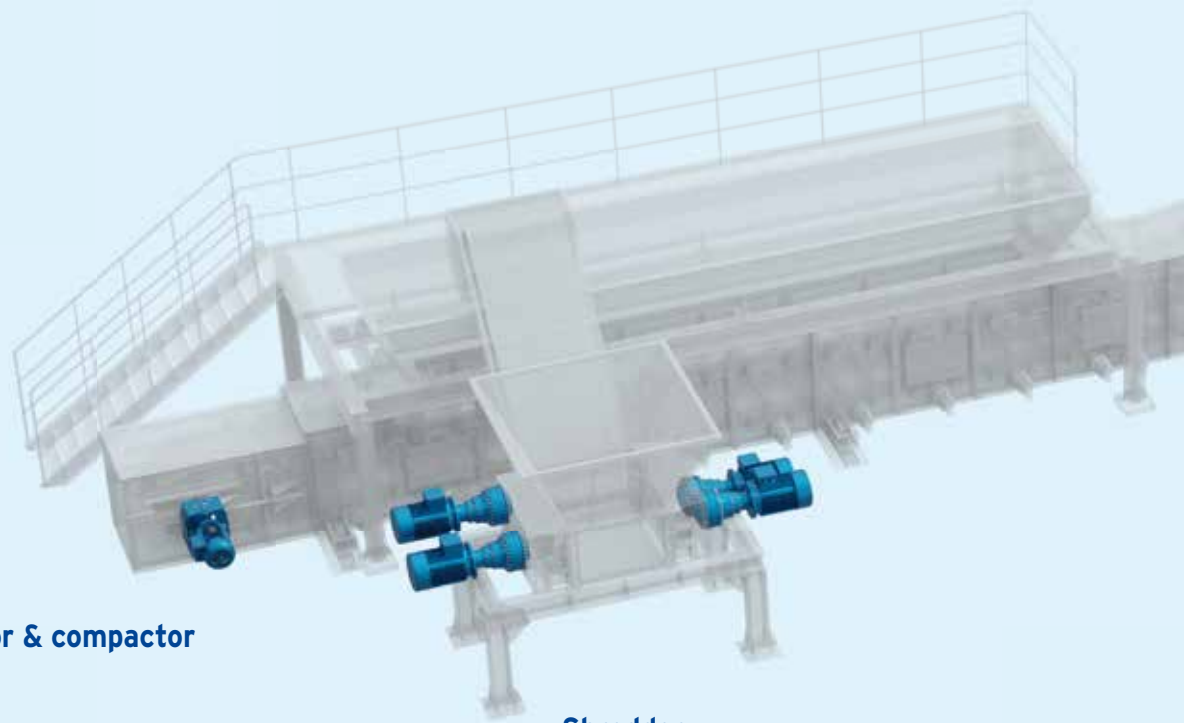

Conveyor & compactor

Shredder



Mobile shredder



Scan the QR code to  
watch the video

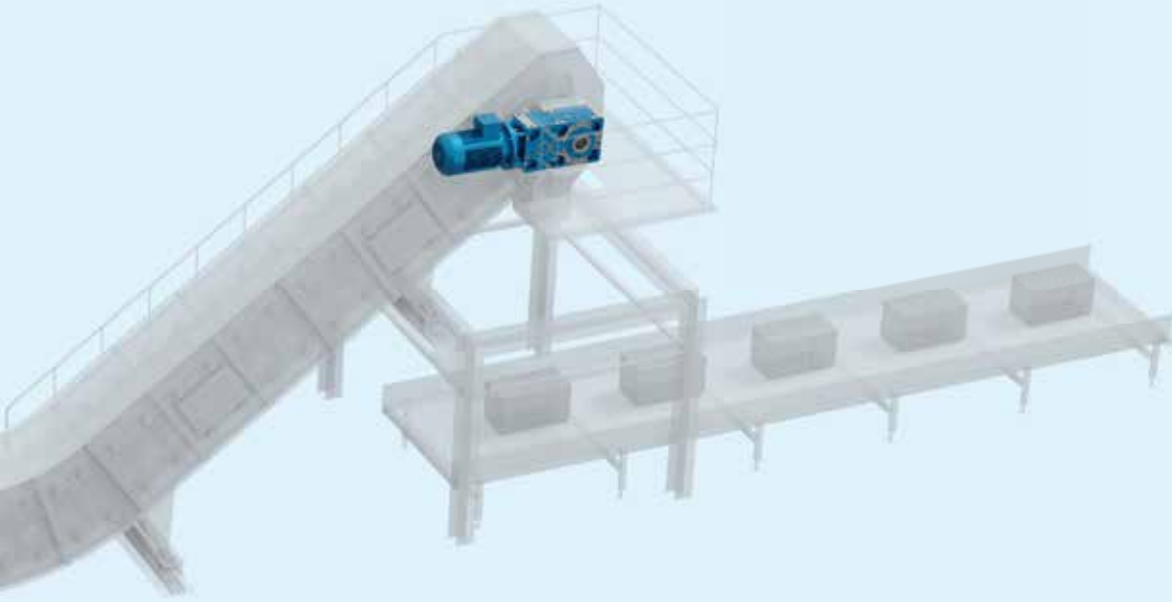

**Screw compactor**

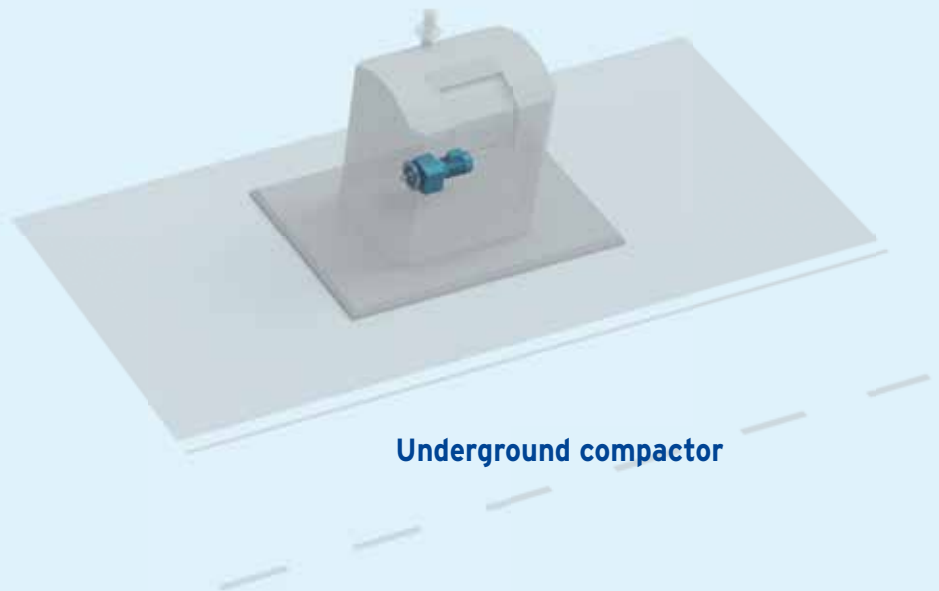

**Underground compactor**



# Conveyor & Compactor



**Helical & Bevel helical G series**

- Backstop device available
- Metric and inches shafts available
- C4, C5 class surface protection according to UNI EN 12944-2 standard available



**Worm A series**

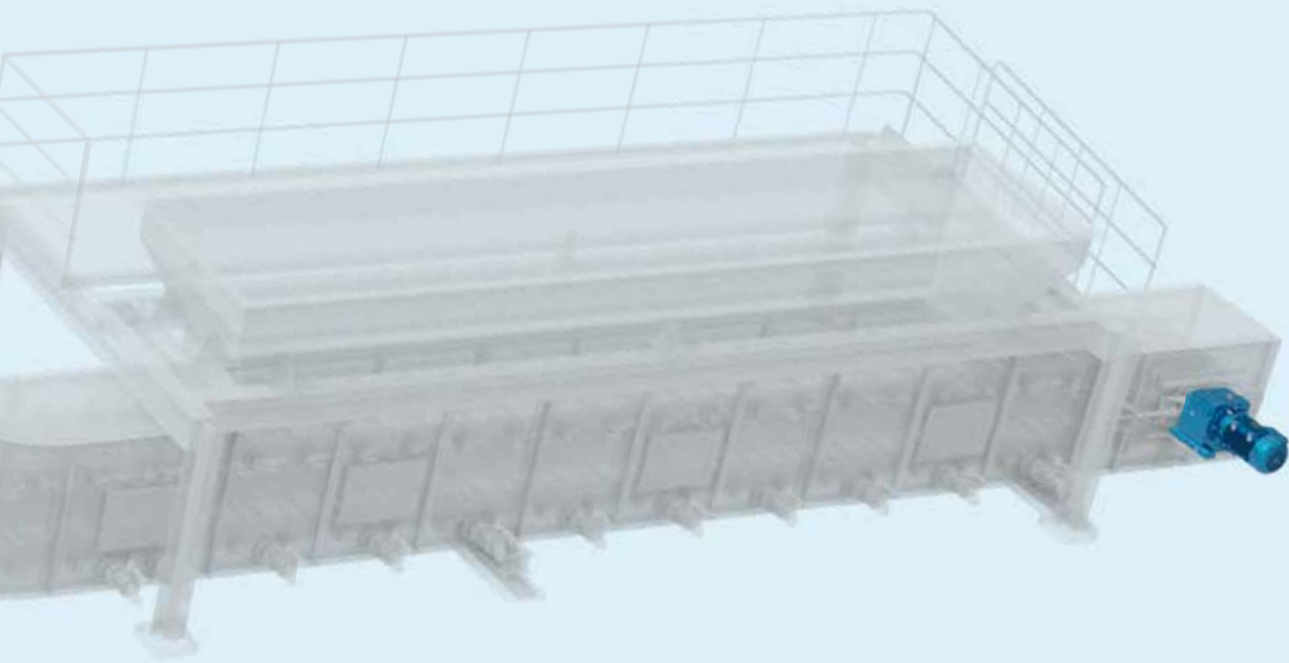

**Coaxial E series**



**Helical inline iFIT series**

# Mobile shredder

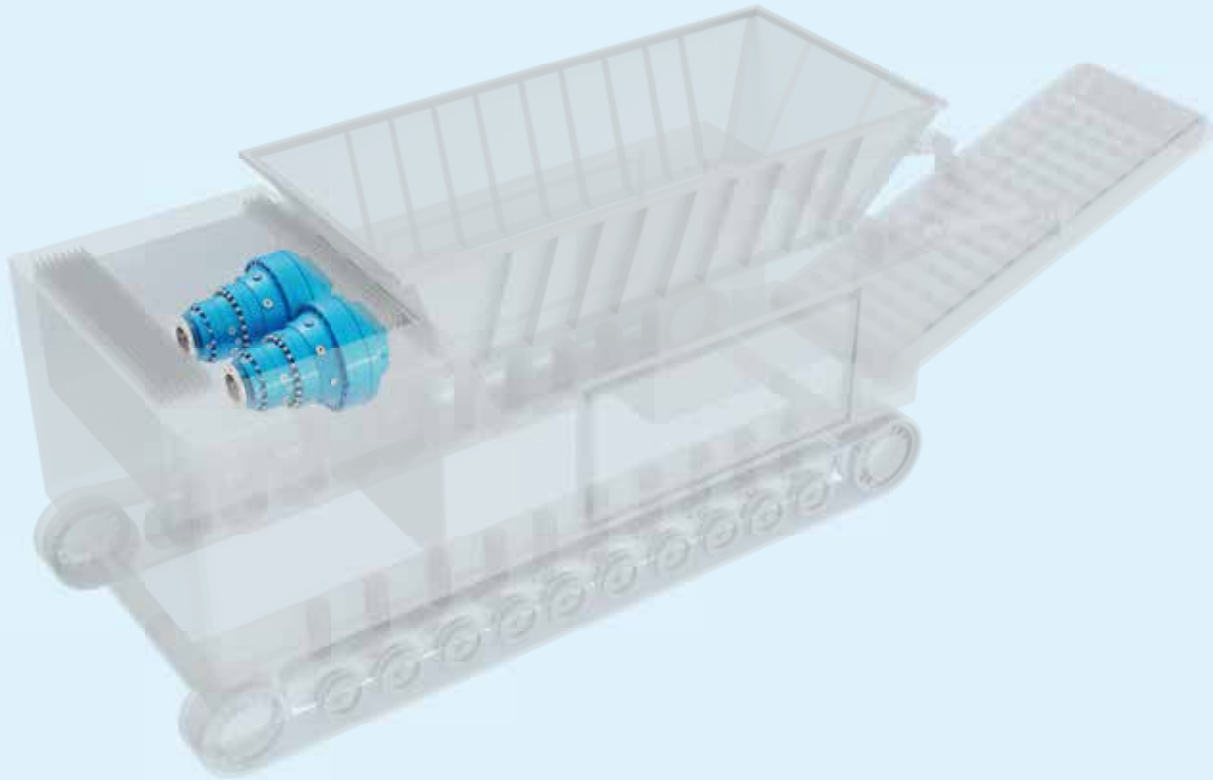

## Planetary EP series

- Compact solution
- High torque density 4 satellites



# Screw compactor

Helical inline iFIT series



Planetary EP series

# Underground compactor



Helical inline iFIT series



Planetary EP series

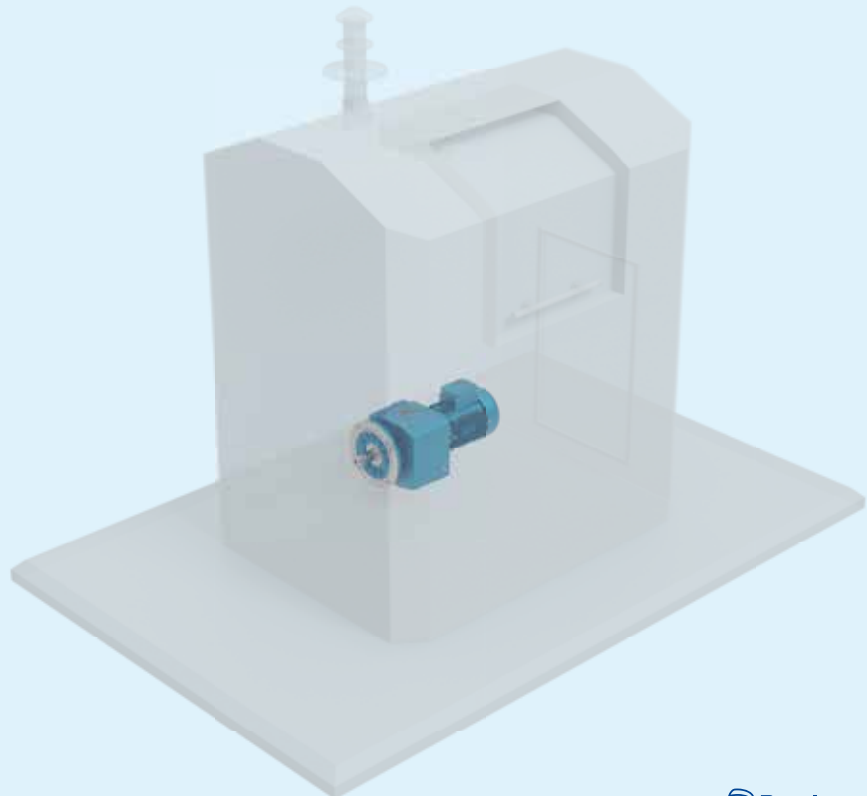

# Shredder

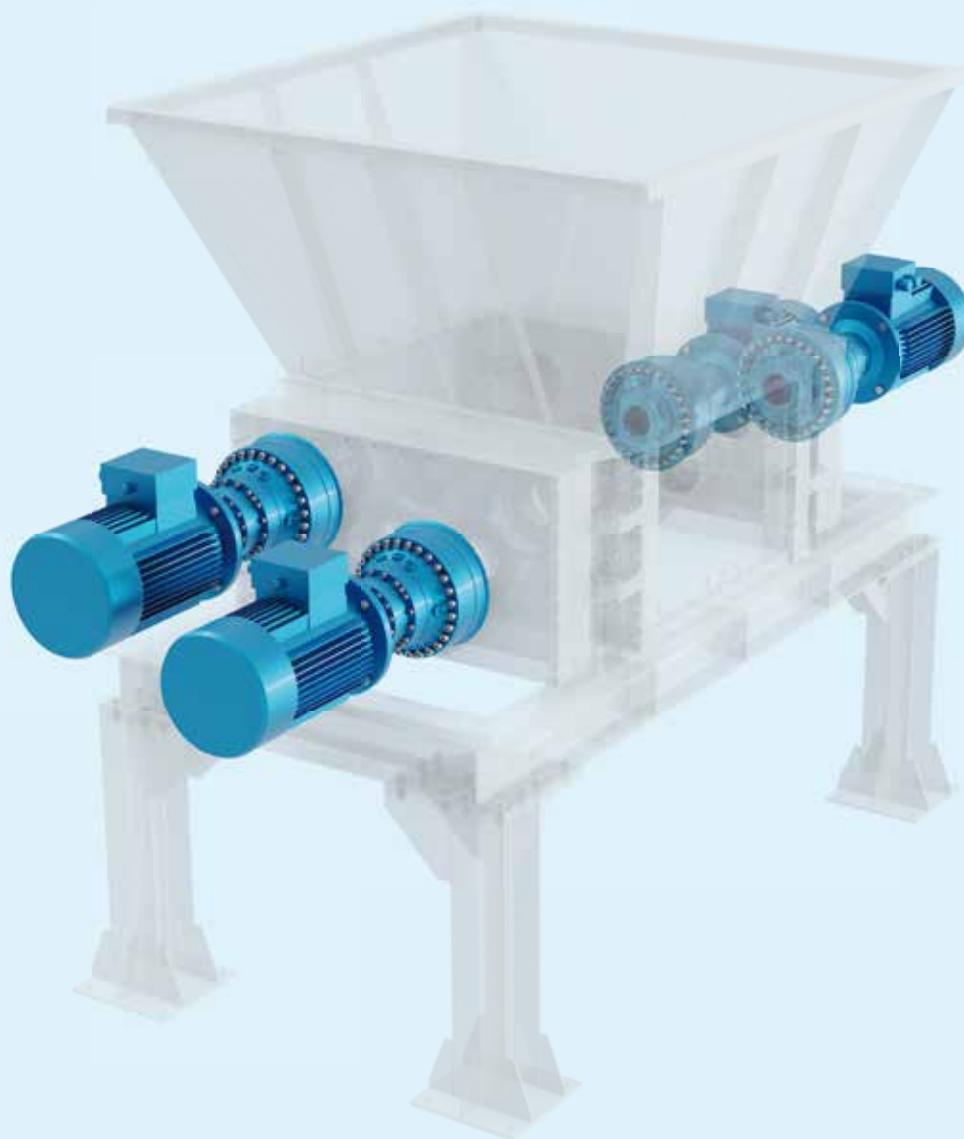

## Helical & Bevel helical G series

- Single piece housing with high structural stiffness
- Flexible mounting arrangements
- High shock load resistance



## Helical & Bevel helical H series

- Customized solutions on request, starting from a modular design
- Torque capacity to 8,850,000 lb in available
- Spheroidal cast iron housing suited for horizontal and vertical mounting
- High shock load resistance



## Planetary EP series

- Modular design
- High torque density
- Torque capacity to 26,500,000 lb in available
- High shock load resistance



# Water treatment

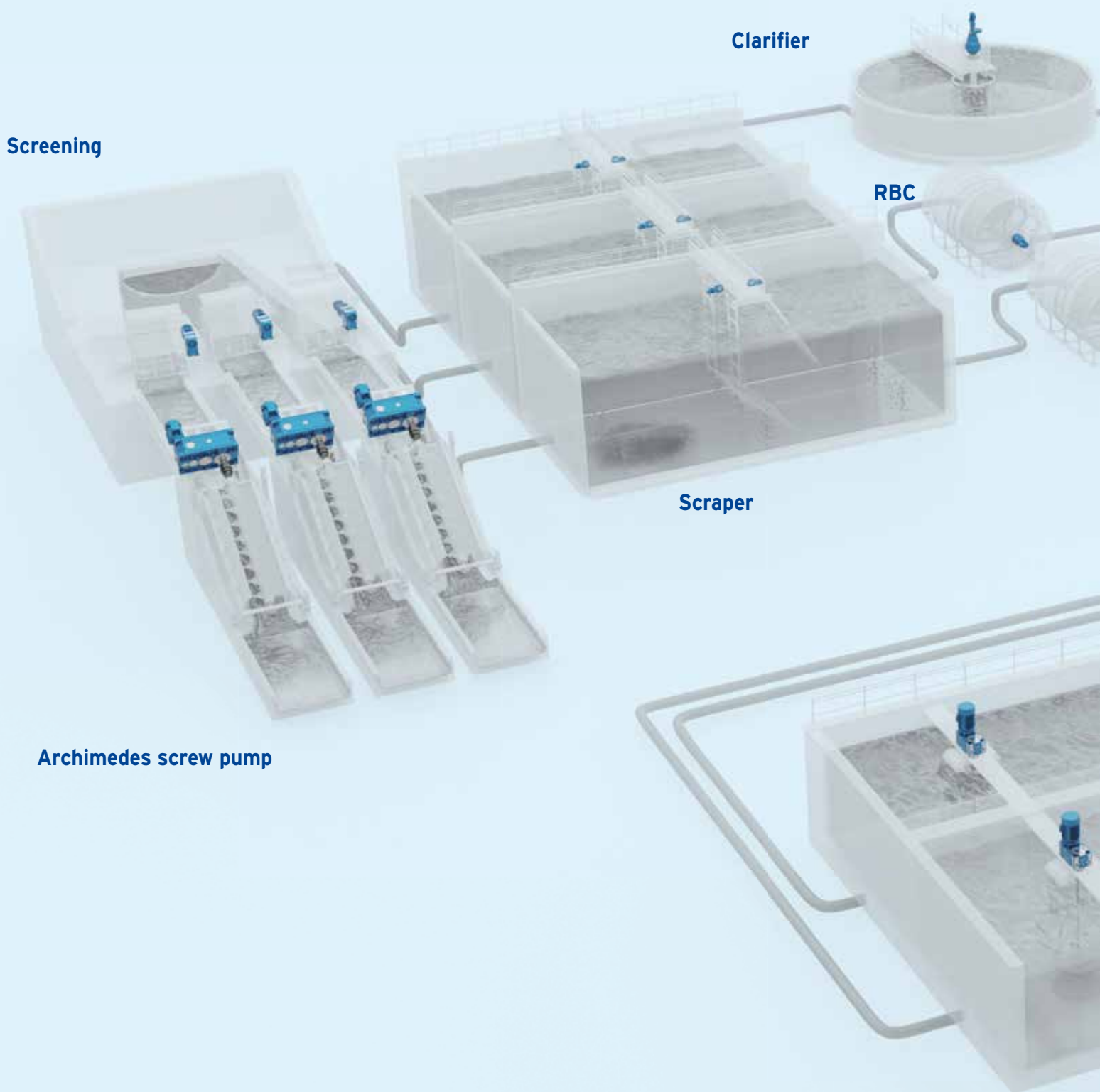

Archimedes screw pump



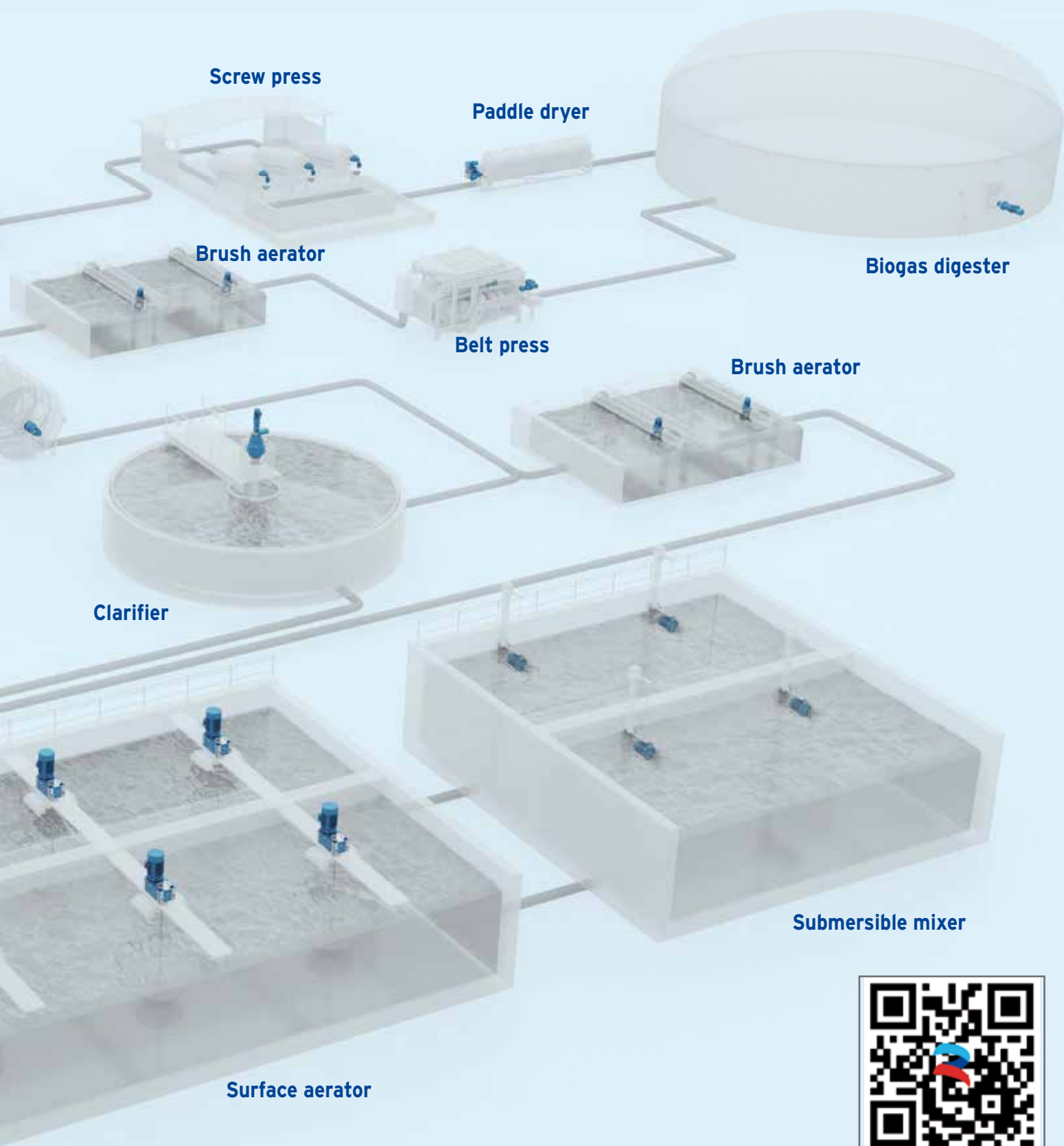

Scan the QR code to watch the video

# Archimedes screw pump

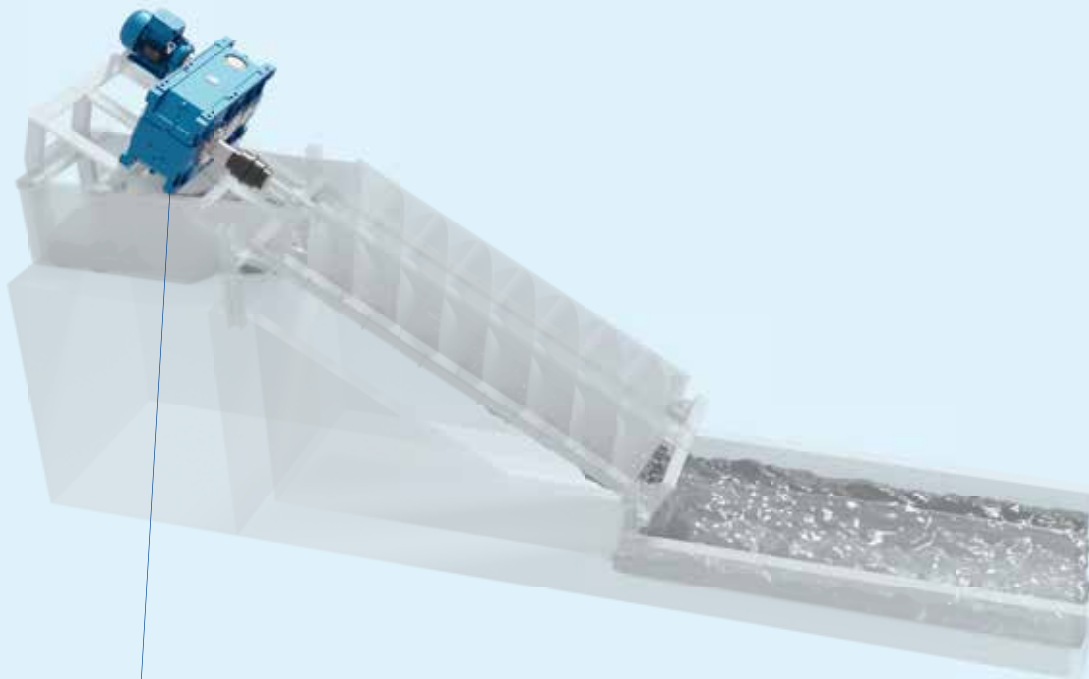

## Helical & Bevel helical G series

- High resistance in harsh conditions
- Premium bearing load capacity
- Premium sealing options
- C4 and C5 class surface protection according to UNI EN 12944-2 available
- Customized solutions available on request
- Suitable for foot mounting

## Helical & Bevel helical H series

- Nominal torque up to 8,850,000 lb in
- High resistance in harsh conditions
- Premium bearing load capacity
- Premium sealing options
- C4 and C5 class surface protection according to UNI EN 12944-2 available
- Customized solutions available on request
- Suitable for foot mounting



# Screening

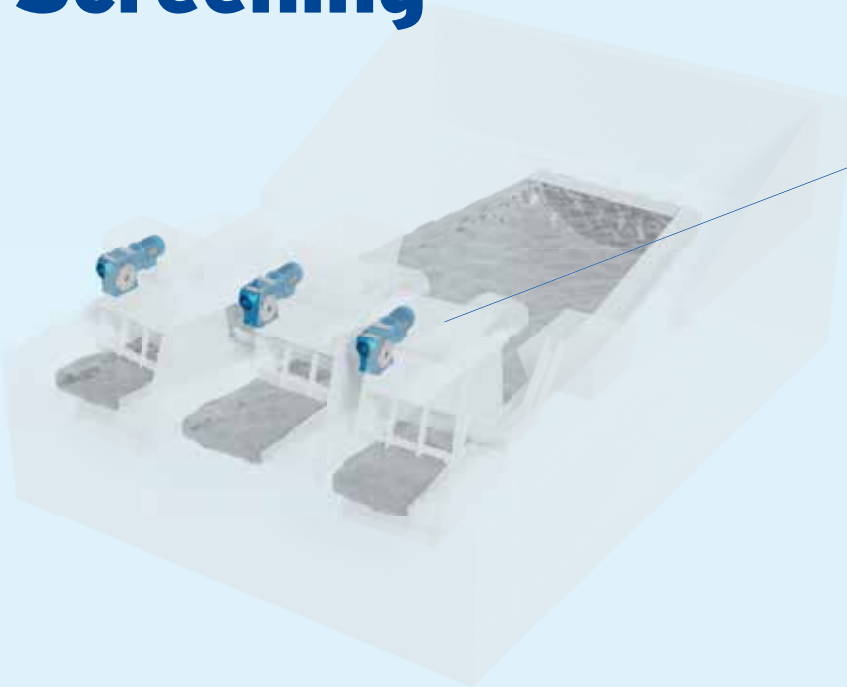

## Worm A series

- Suitable for shaft and flange mounting



## Planetary EP series

- Suitable for shaft and flange mounting

# Belt press

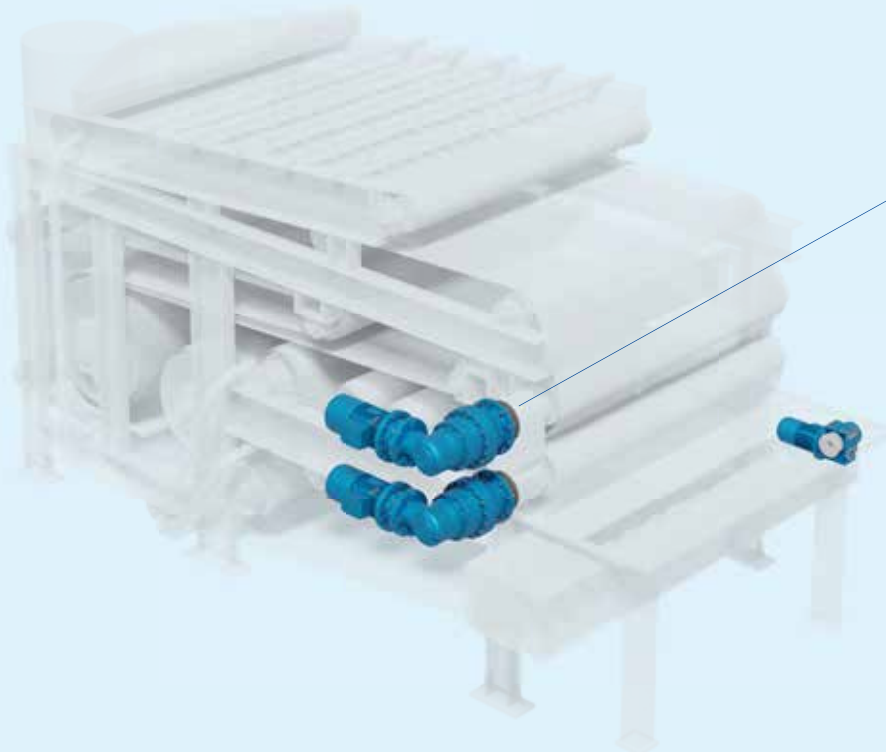

## Planetary EP series

- Modular design
- High flexibility in layout and mounting position
- Large number of output shaft types
- High resistance in harsh and dusty environments
- High torque density

# Scraper

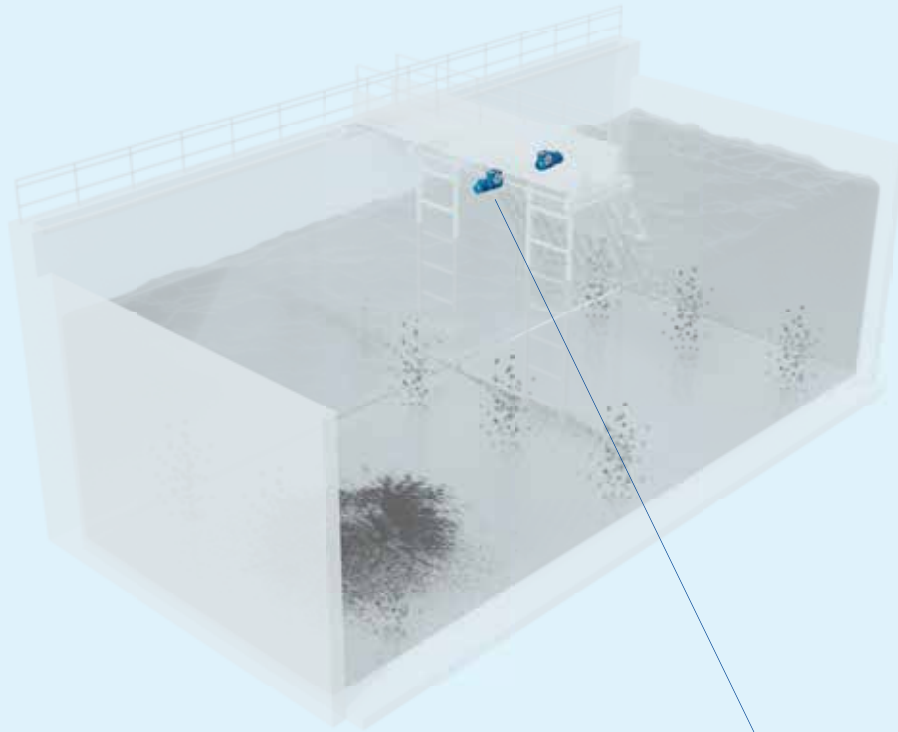

## Helical & Bevel helical G series

- Standard hollow low speed shaft (metric or inches)
- High resistance in harsh conditions
- Premium bearing load capacity
- Premium sealing options
- C4 and C5 class surface protection according to UNI EN 12944-2 available
- Customized solutions available on request



## Worm A series

- Standard hollow low speed shaft
- High resistance in harsh conditions
- Premium bearing load capacity
- Premium sealing options
- C4 and C5 class surface protection according to UNI EN 12944-2 available
- Customized solutions available on request

# Clarifier

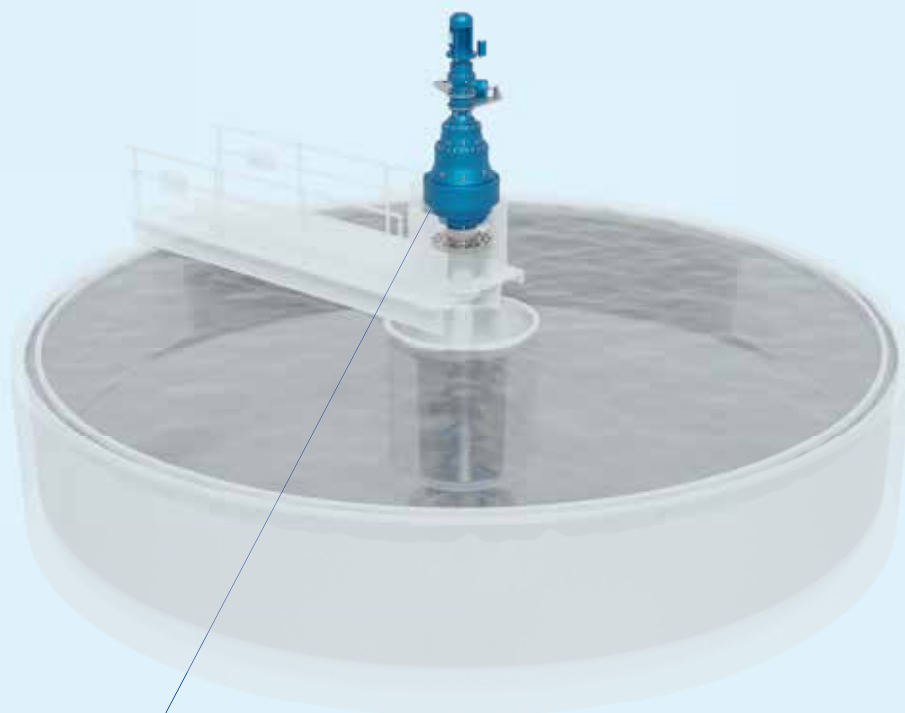

## Planetary EP series

- Complete drive solution
- Modular design with unlimited reduction ratios, theoretically unlimited reduction ratios (1:30 000)
- Nominal torque up to 26,500,000 lb in
- High resistance in harsh conditions
- Premium bearing load capacity
- Premium sealing
- Easy solution to mount a load cell
- Torque limiter available
- Wheel flange option

## Slewing drives EPS series

- Standard or customized slewing gearbox available
- Double centering or front flange solution
- Loose or integral slewing pinion
- Direct connection to hydraulic or electric motor (IEC or NEMA)

## Helical & Bevel helical G series

# Surface aerator

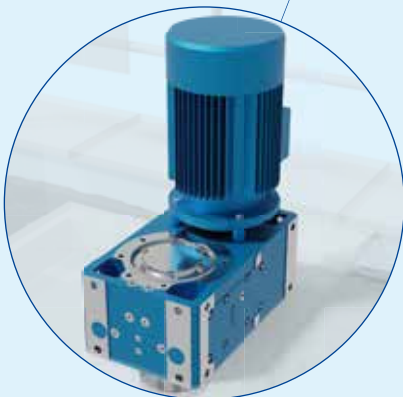
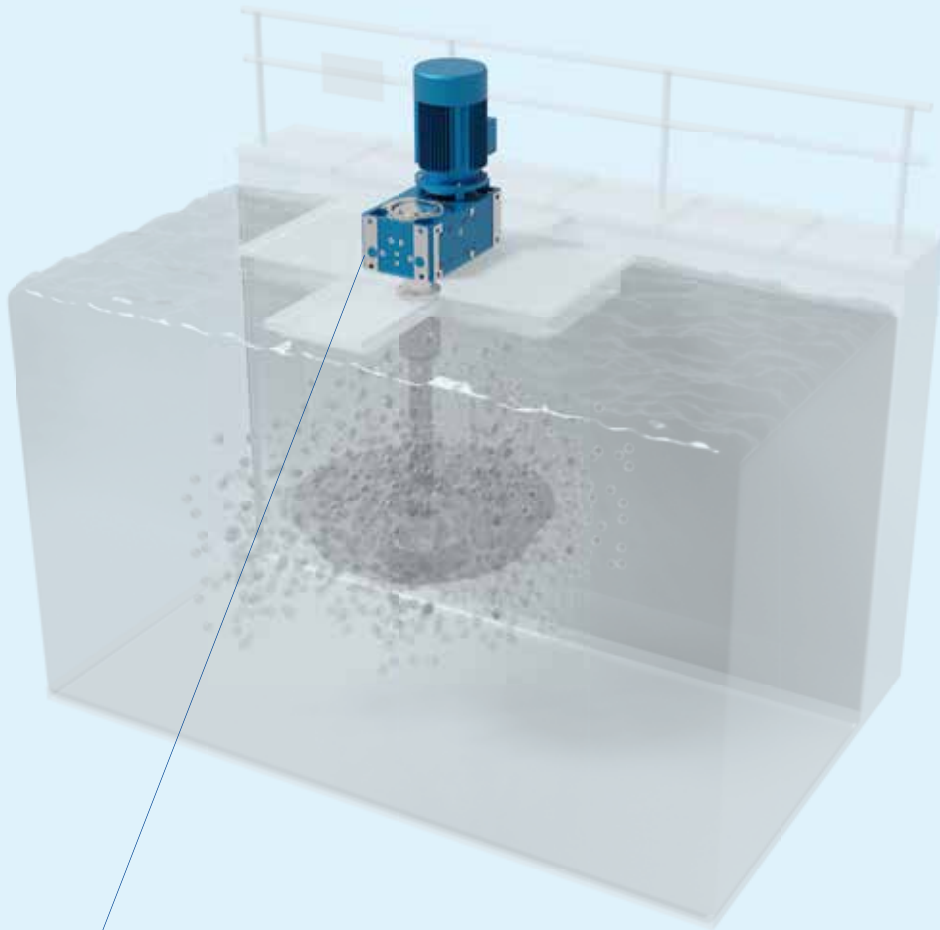

## Helical & Bevel helical G series

- Dry well available
- Design for agitators available
- Large radial load capacity
- Metal plugs
- Premium sealing
- C4 and C5 class surface protection according to UNI EN 12944-2 available

## Planetary EP series

- Large radial load capacity
- Ground gears: low noise
- Metal plugs
- Premium sealing
- C4 and C5 class surface protection according to UNI EN 12944-2 available

## Helical inline iFIT series

- Drop-in design to major competitors brands
- Metric or inches output shafts
- Foot or flange mounting design
- Compact electric motors as standard
- Input IEC or NEMA adapter available

# Brush aerator

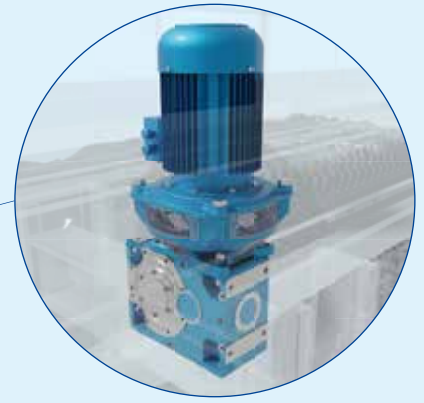
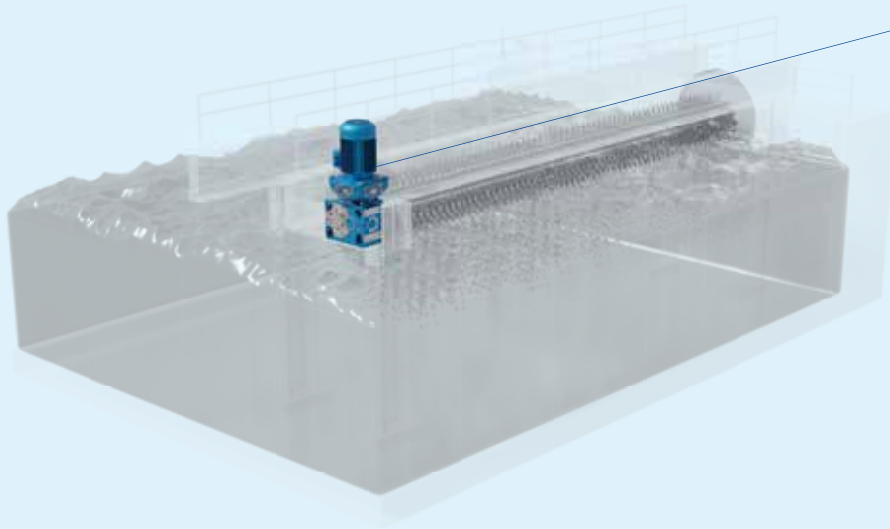

## Helical & Bevel helical G series

- Bell housing made of spheroidal cast iron for IEC and NEMA electric motors
- Flexible coupling available
- Standard heavy duty radial load capacity

# Submersible mixer

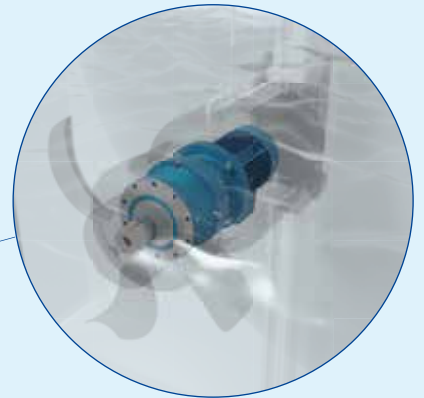
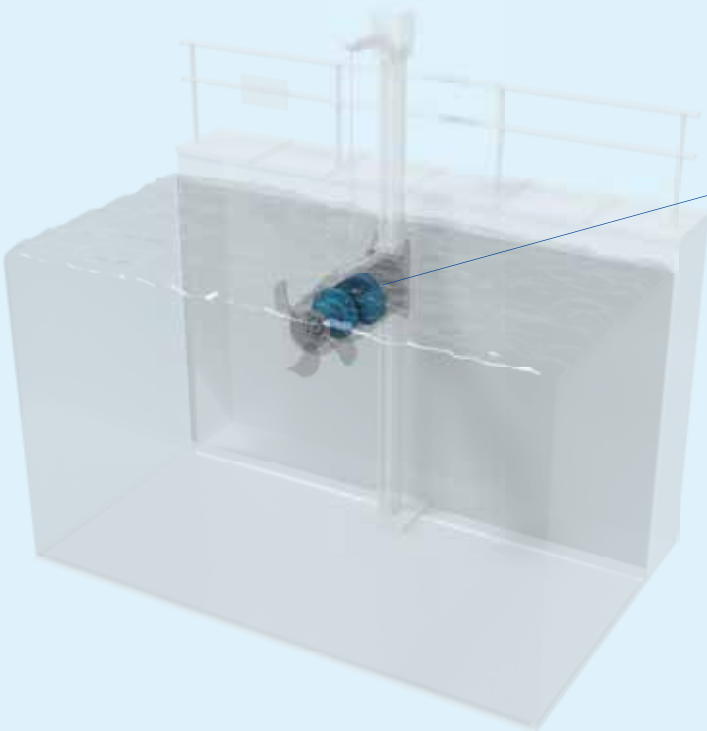

## Planetary EP series

- Very compact solution
- Ground gears

# Screw press

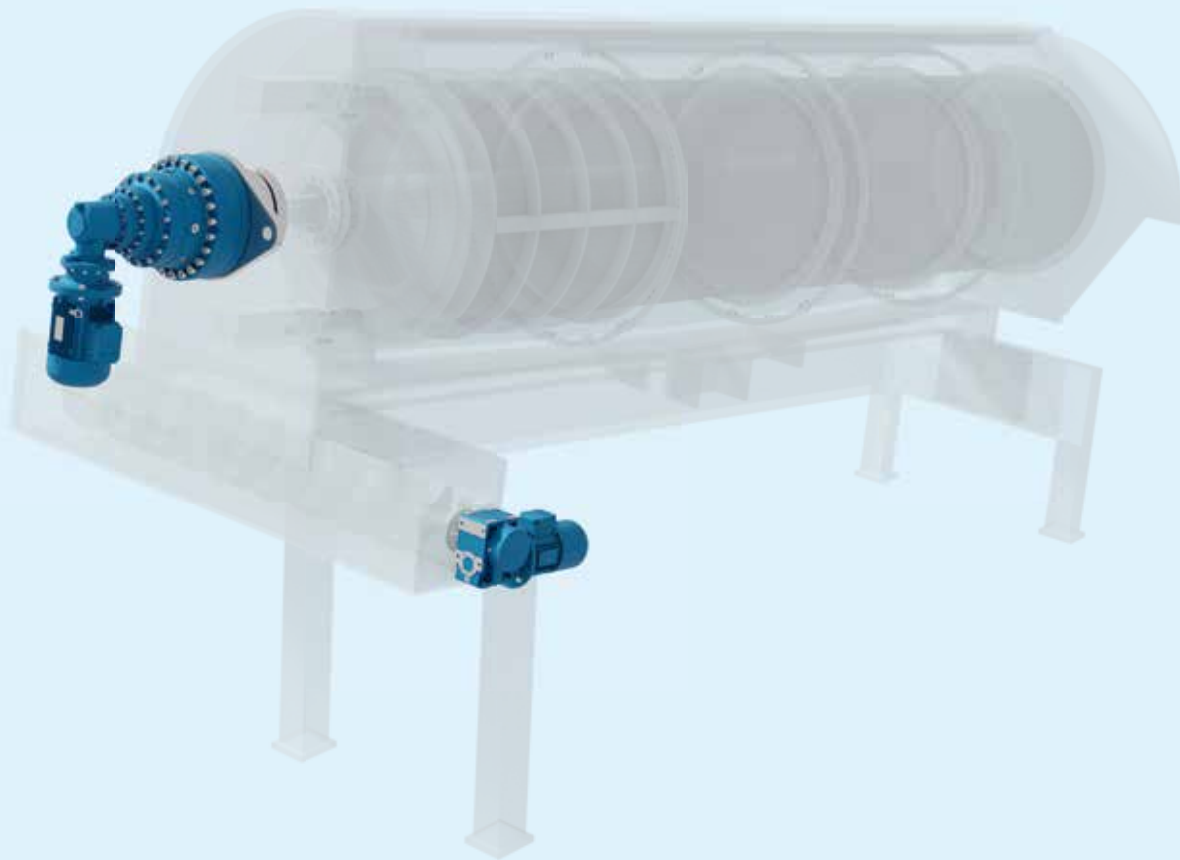

## Planetary EP series

- High resistance in harsh and dusty environments
- High torque density
- Standardized or customized torque arms for shaft mounting available



## Helical & Bevel helical G series



# Rotating biological contactor



**Helical combined unit**

**Planetary EP series**

- Large number of shaft mounted solutions
- Hollow shaft + shrink disc
- Hollow shaft with keyway for easy mounting
- Integral wheel flange option available

# Hose pump

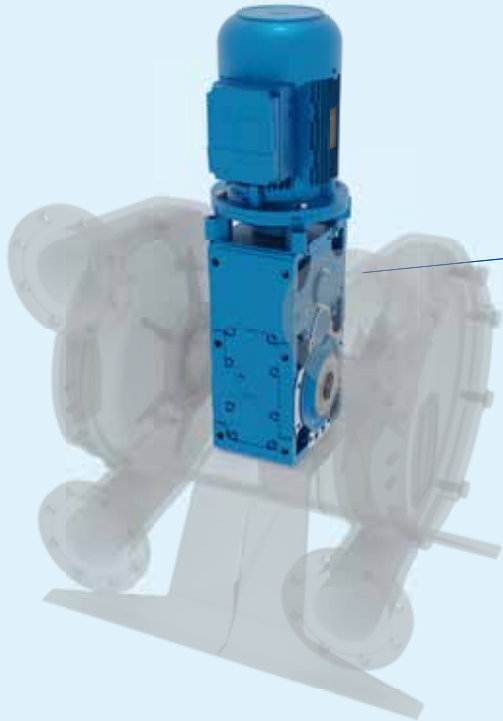

## Bevel helical G series

- High resistance in harsh conditions
- Premium bearing load capacity
- Premium sealing options
- C4 and C5 class surface protection according to UNI EN 12944-2
- ATEX certification on request

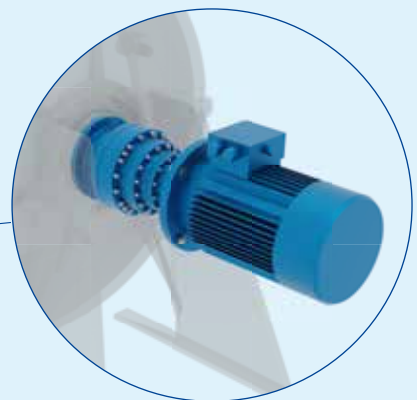
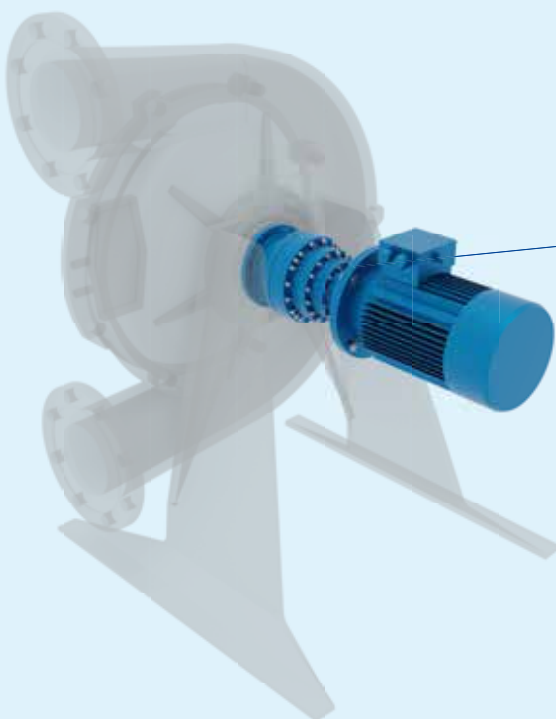

## Planetary EP series

- Large number of output shaft types
- High resistance in harsh and dusty environments
- High torque density
- Labyrinth seals available
- ATEX certification on request

# Paddle dryer

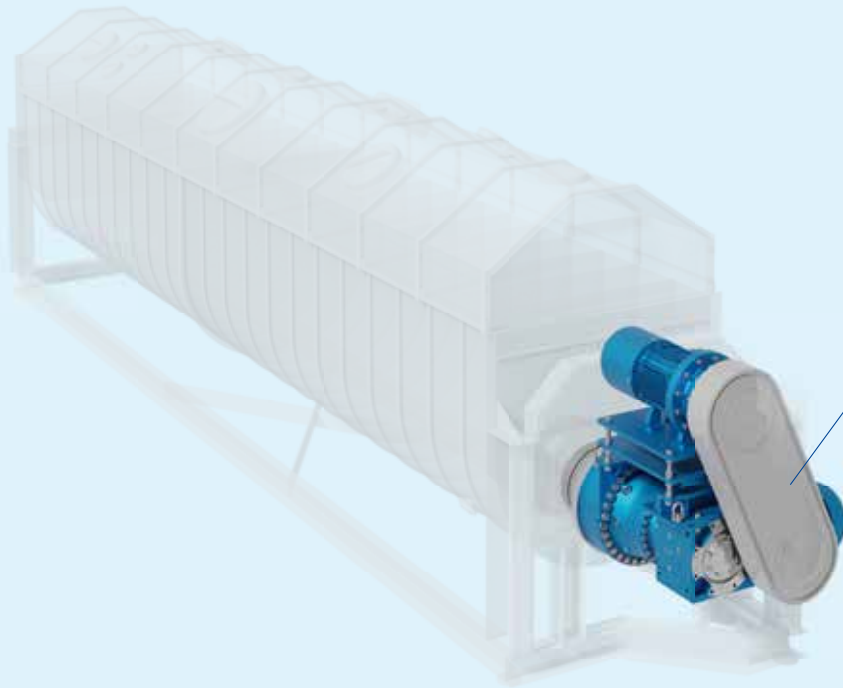

## Combined planetary EP series

- Bespoke compact solution available: a completely modular combined planetary + helical gearbox
- Large thermal capacity
- Torque capacity to 26,500,000 lb in available
- High resistance in harsh conditions
- High torque density

### G Series

#### Helical & bevel helical gear reducers & gearmotors

20 sizes 40 ... 401

Nominal torque ( $T_{N2}$ ) up to 900,000 lb in

Transmission ratio ( $i_N$ ) 2 ... 160

##### Features

- Single piece cast or ductile iron housings available. Machine face on all 4 sides
- Wide range of sizes & ratios available
- Suitable for NEMA or IEC motor inputs
- Extended housing design for large center to center distance requirements
- Case carburized gear sets
- Helical gear pairs with ground profile
- Ground GLEASON spiral bevel gear set
- Bell housing for IEC and NEMA motors available
- Bell housing with or without elastic coupling available
- Optional synthetic oil for food industry

##### Benefits

- Modular design allows for flexibility in mounting positions
- Minimum maintenance requirements
- High performance and reliability
- Strength and reliability for heavy duty applications



### H Series

#### Helical & bevel helical gear reducers

12 sizes 4,000 ... 8,001

Nominal torque ( $M_{N2}$ ) up to 8,850,000 lb in

Transmission ratio ( $i_N$ ) 8 ... 315

##### Features

- Universal spheroidal cast iron housing suited for horizontal and vertical mounting having integral feet
- Two-piece housing with stiffening ribs for high structural stiffness and high oil capacity
- 12 sizes, train of gears solutions and non-standard designs
- Helical gear units with 2 and 3 gear stages
- Bevel helical gear units with 1, 2 and 3 gear stages
- Case hardened and hardened gear pairs
- Helical gear pairs with ground profile
- GLEASON spiral bevel gear pairs with ground profile

##### Benefits

- One of the widest torque range from a single supplier
- Customized solutions on request starting from a standard modular design
- Short delivery times
- Optimized design for heavy industry applications
- Wide range of accessories available



## EP Series

### Planetary gear reducers & gearmotors

24 sizes 001 ... 3,000

Nominal torque ( $T_{N2}$ ) up to 26,550,000 lb in

Transmission ratio ( $i_N$ ) 3.55 ... to unlimited

#### Features

- Multiple input stages in inline or right angle configurations
- Modular design
- Suitable with NEMA, IEC motors or hydraulic input
- Final stage gear set case carburized & ground with nitriding on internal sun gears
- Cylindrical spur gear with ground profile
- GLEASON spiral bevel gear pairs with ground profile
- Very compact size
- Wide range of accessories and non-standard designs
- Low backlash, enhanced stiffness and heavy duty bearings as a standard
- Improved lubrication system
- Wide range of hydraulic brakes
- Optional synthetic oil for food industry

#### Benefits

- Easy and functional flange, foot, or shaft-mounting design
- High torque transmitted
- Extended range of transmission ratios



## EP Combined Units Series

### Combined planetary gear reducers & gearmotors

24 sizes 001 ... 3,000

Nominal torque ( $M_{N2}$ ) up to 26,550,000 lb in

Transmission ratio ( $i_N$ ) according to Customer's requirements

#### Features

- Planetary drives combined with other Rossi products to optimize performances
- Possible combinations with standard Rossi products utilizing planetary drives in conjunction with worm, inline, helical or bevel drive/gearmotors

#### Benefits

- Flexibility and adaptability to specific application needs
- Large thermal capacity
- High torque density
- Unlimited reduction ratios available



### EP Slewing Series

Planetary Slewing drives

10 sizes 007 ... 250

Nominal torque ( $M_{N2}$ ) up to 3,540,000 lb in

Transmission ratio ( $i_N$ ) 12.5 ... 2,800

Excellent specific series from the standard EP series

#### Additional features

- 10 modular sizes
- 3 different output supports: Dual pilot flange (R), Dual compact pilot design (S), single pilot flange (H)
- Loose or integral slewing pinions available
- Wide range of hydraulic brakes

#### Additional benefits

- Wide range of drives allows for very high performance while being cost-efficient



### A Series

Worm gear reducers & gearmotors

14 sizes 32 ... 250

Nominal torque ( $T_{N2}$ ) up to 71,000 lb in

Transmission ratio ( $i_N$ ) 7 ... 16,000

#### Features

- Universal mounting with integral feet on the housing and B14 flanges
- Rigid and precise cast iron single piece housing
- Forced ventilation for high thermal power dissipation (size > 100)
- Worm wheels made of nickel bronze with high performance capability. High load capacity and wear resistance
- Wide range of accessories and non-standard designs
- Optional synthetic oil for food industry

#### Benefits

- Universal mounting positions
- High performance and reliability
- Smooth and precise running, reduced and constant backlash
- Extremely quiet and constant performance even in the hardest applications





## **iFit** iC Series

### Helical inline gearmotors

8 sizes iC 27 ... iC 97

Nominal torque ( $M_{N2}$ ) up to 30,000 lb in

Transmission ratio ( $i_N$ ) 3.4 ... 290



## **iFit** iO Series

### Bevel helical gearmotors

7 sizes iO 37 ... iO 97

Nominal torque ( $M_{N2}$ ) up to 32,300 lb in

Transmission ratio ( $i_N$ ) 5.4 ... 197



## **iFit** iP Series

### Parallel shaft helical gearmotors

8 sizes iP 27 ... iP 97

Nominal torque ( $M_{N2}$ ) up to 43,100 lb in

Transmission ratio ( $i_N$ ) 3.77 ... 281.71



#### Features

- Fully interchangeable with market standards
- 100% Italian manufacturing
- Full range with robust cast iron housing
- Gear precision as per DIN/ISO/AGMA 6 or better
- New IE2, IE3 compact electric motors
- High quality sealing solutions
- Round shaped, smooth housing surface
- Higher Torque than competitor brands

#### Benefits

- "Plug & Play" with no re-engineering costs
- Superior quality, minimum maintenance
- High performance and reliability: minimum deformation, no gearing misalignment, no vibration, and low noise level
- Energy saving, low noise level, reduced backlash
- Premium efficiency, long lifetime and no oil leakage
- Wash down capability.
- Up to 12% higher torque ratings than market standard

### E Series

#### Coaxial gear reducers & gearmotors

16 sizes 32 ... 180

Nominal torque ( $T_{N2}$ ) up to 90,000 lb in

Transmission ratio ( $i_N$ ) 4 ... 6,300

#### Features

- Universal mounting with lower/upper feet and B5 flange integral to the housing
- Rigid and precise cast iron single piece housing with high structural stiffness
- Helical tooth design with ground & carburized gearing
- Wide range of sizes
- Standard IEC motor input adapter
- Optional synthetic oil for food industry

#### Benefits

- Long life
- Minimum maintenance requirements
- High performance and great reliability
- Strength and reliability for heavy duty applications



### AS Standardfit Series

#### Worm gearmotors

6 sizes 118 ... 742

Nominal torque ( $T_{N2}$ ) up to 6,000 lb in

Transmission ratio ( $i_N$ ) 6 ... 75

#### Features

- Mounting with lower integral feet and B14 flanges on 2 faces integral on the housing
- Rigid and precise cast iron single piece housing
- Worm wheels made of nickel bronze with controlled phosphor content to achieve improved performance, a high load capacity, great reliability and wear resistance
- No thermal limitation
- Tapered roller bearings on worm shaft
- Motor mounting flange integral to the housing

#### Benefits

- Interchangeability with major manufacturers
- High performance and greater reliability
- Smooth and quiet running



## TX Series

### Premium line electric asynchronous three-phase motors and brake motors

Sizes - IEC frames 63 to 315

Horsepower capacity 1/8 to 150HP

2, 4, 6 Pole motors available

#### Features

- IEC standard motors
- Protection: IP 55 standard, up to IP 66 on request
- IE3 Energy efficiency
- Standard and safety brake (AC. DC)
- Optional complex executions available (encoders, axial cooling, increased protection, etc.)

#### Benefits

- Compactness and flexibility
- Suitable for running with inverter
- Reduced environmental impact and energy saving



## dDrive Inverter Series

### Decentralized Drive

Sizes A, B, C

3/4HP to 10HP available

Supply Voltage 3x200V AC...480V AC

280V DC...680V DC

Rated current 1.7A...16.5A

#### Features

- Decentralized Frequency Inverter
- Designed for Rossi IE2, IE3 electric motors
- Aluminum Housing IP 65
- Sensorless Vector Control
- Safe Torque Off (STO)
- Configurable I/O's board and internal PLC
- A large number of field buses available
- Bluetooth Interface

#### Benefits

- Reduced electric cabinet dimension and cooling systems
- Compact solution of inverter, motor, and gearbox
- Suitable for hard environmental operating conditions
- No need of motor encoder for speed control
- High Safety Performance Level (up to PL E)
- To develop your own dedicated control functions
- Ease integration with existing automation controllers
- Fast and smart inverter parametrization access



# Gear reducers and gearmotors

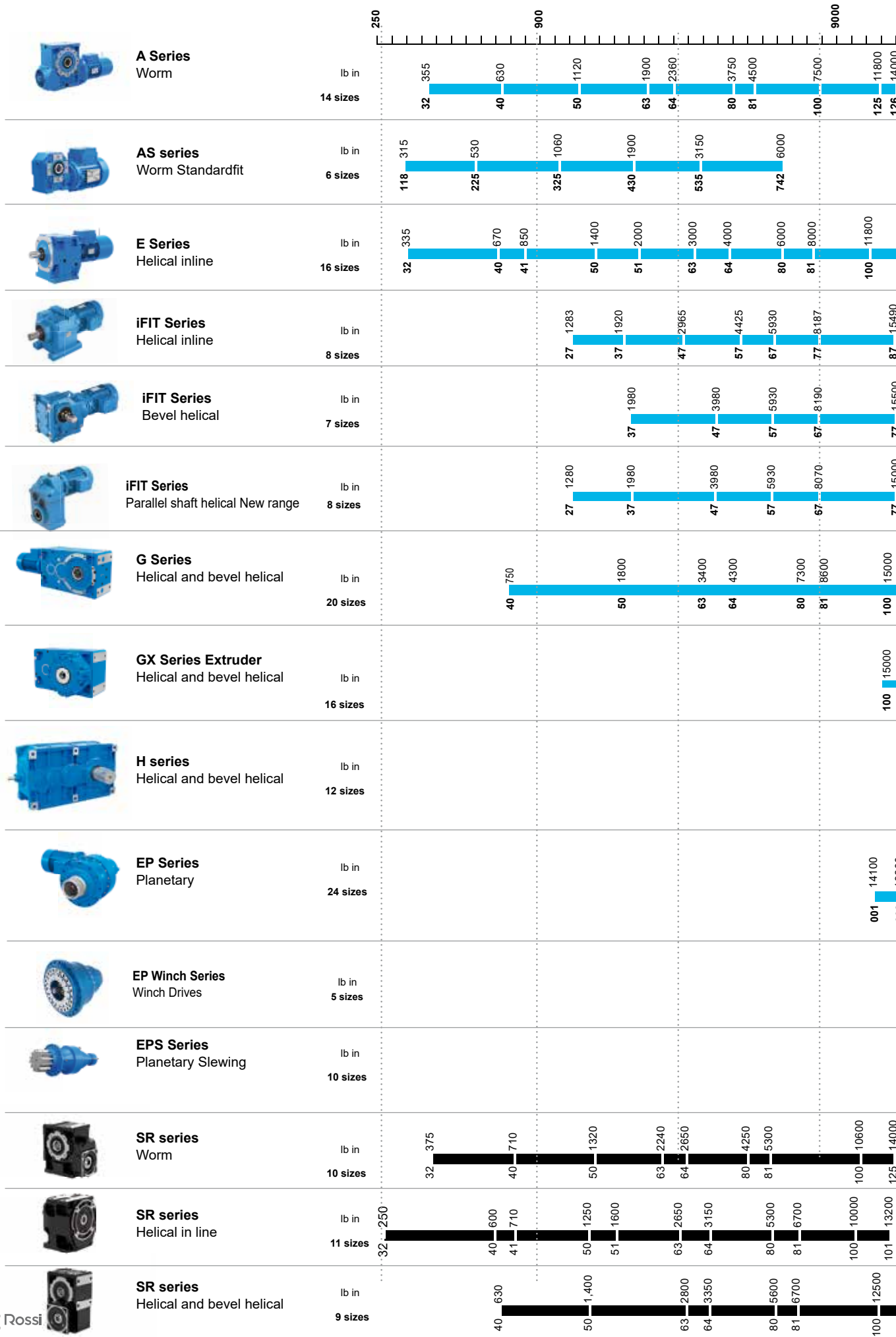

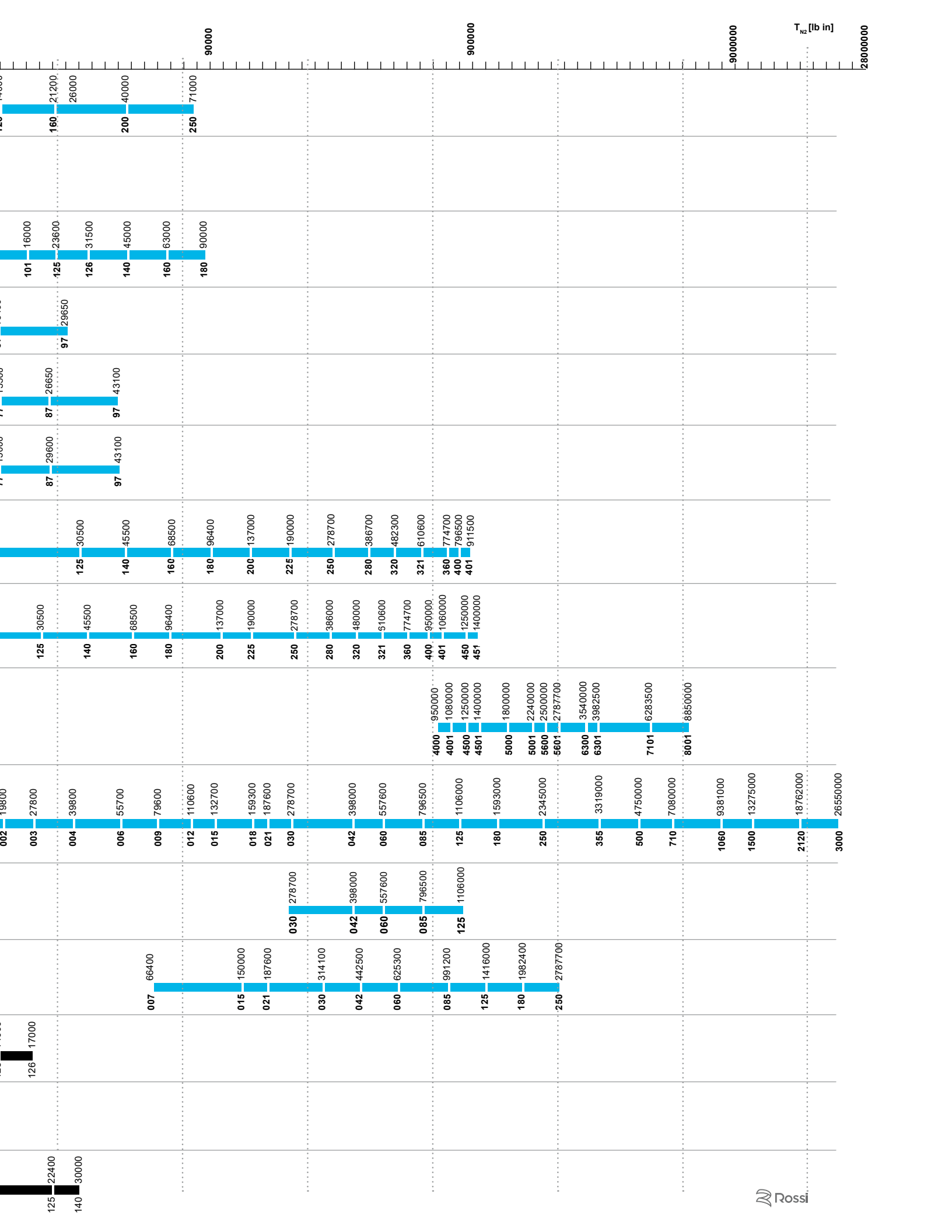





CLARIFIER  
EPS SERIES



PADDLE DRYER  
EP SERIES



BRUSH AERATOR  
G SERIES

**We deliver  
reliable  
solutions  
worldwide**



SECONDARY CLARIFIER  
EP SERIES



PRIMARY CLARIFIER  
G SERIES



BRUSH AERATORS  
G SERIES





RBC  
EP SERIES



BRUSH AERATOR  
G SERIES



SURFACE AERATOR  
G SERIES



ARCHIMEDES SCREW PUMP  
G SERIES



SCREENING  
A SERIES





# Solutions for an evolving industry

In the global marketplace, our customers, investors, partners value our products and services for two reasons: excellence and reliability. At Rossi we utilize change as a strategic lever for our growth. "Solutions for an evolving industry" fully

expresses our corporate philosophy: We are a flexible and dynamic reality, able to satisfy all requirements of a continuously evolving industrial world, thanks to our innovative solutions.

- Cutting-edge manufacturing
- Specialized housing machining
- Extensive systematic controls
- Experience and know-how
- Excellence and innovation
- Reliable customer support.

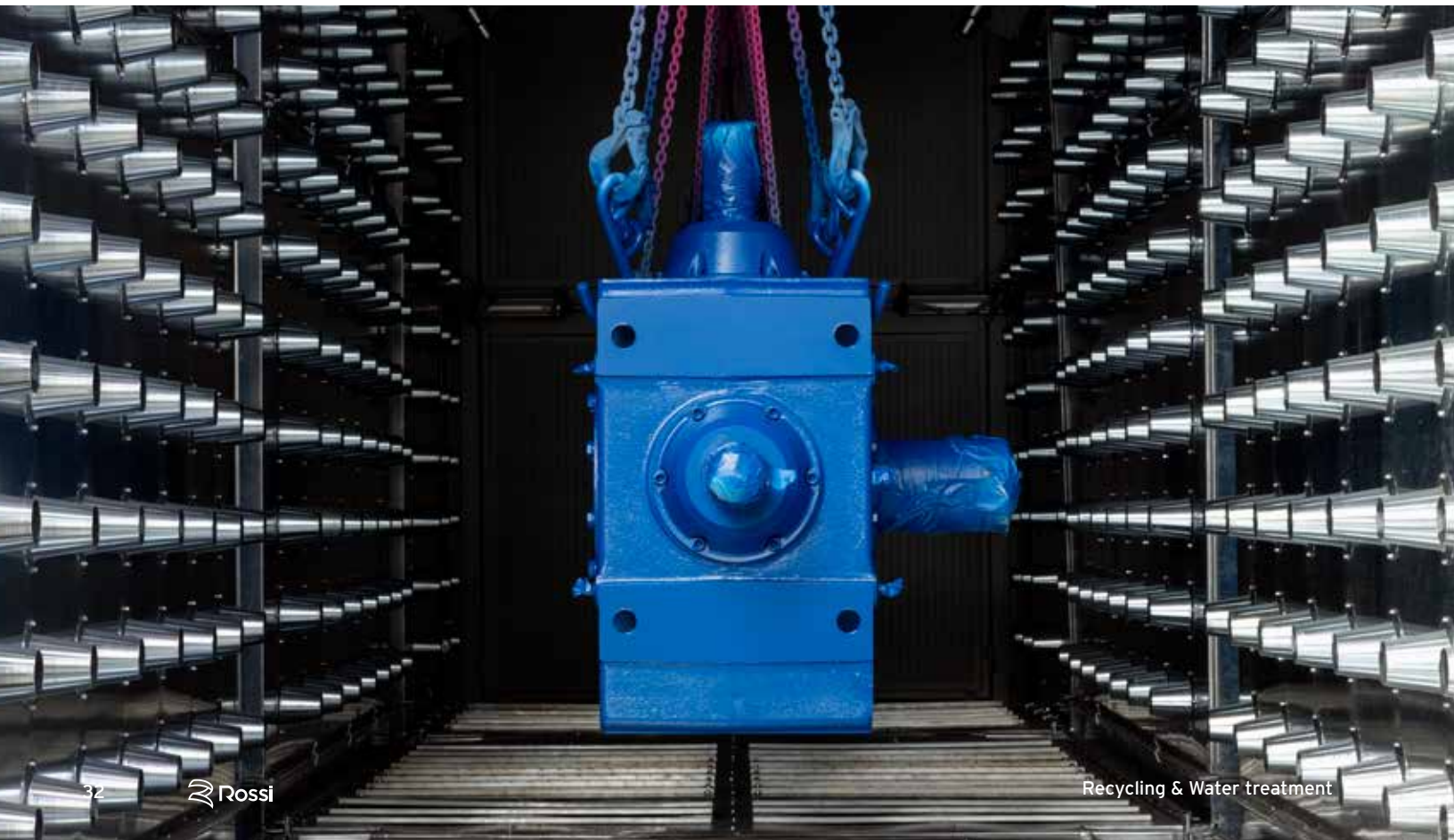

# We have a solution for every segment

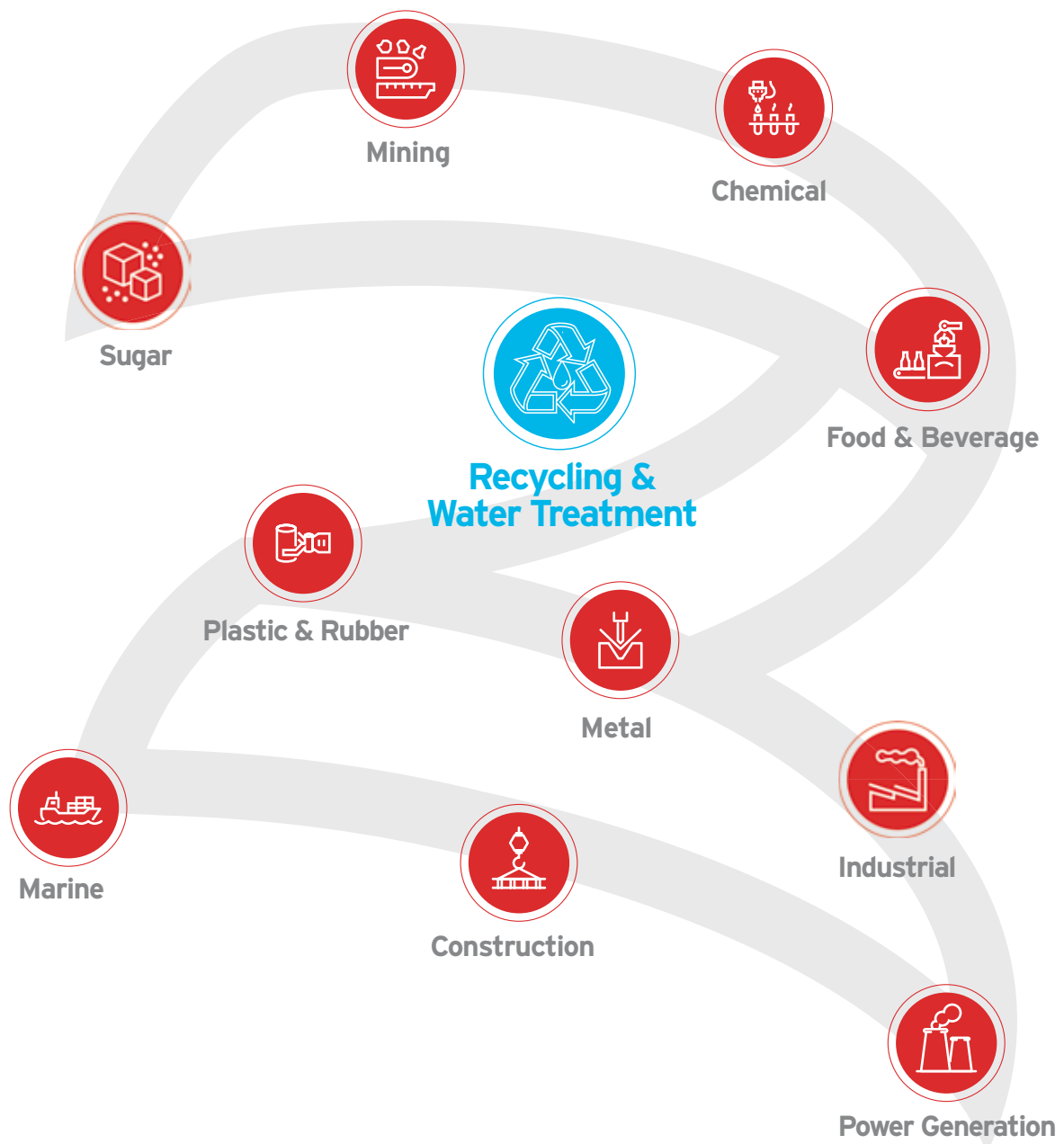

# Global presence local service



## Local support

Sales, customer service,  
technical support, spare parts



## 18 branches\*



## Worldwide distribution network\*



\*All contacts available on [www.rossi.com](http://www.rossi.com)

 Main offices

 Affiliated companies

 Production facilities/Assembly plants

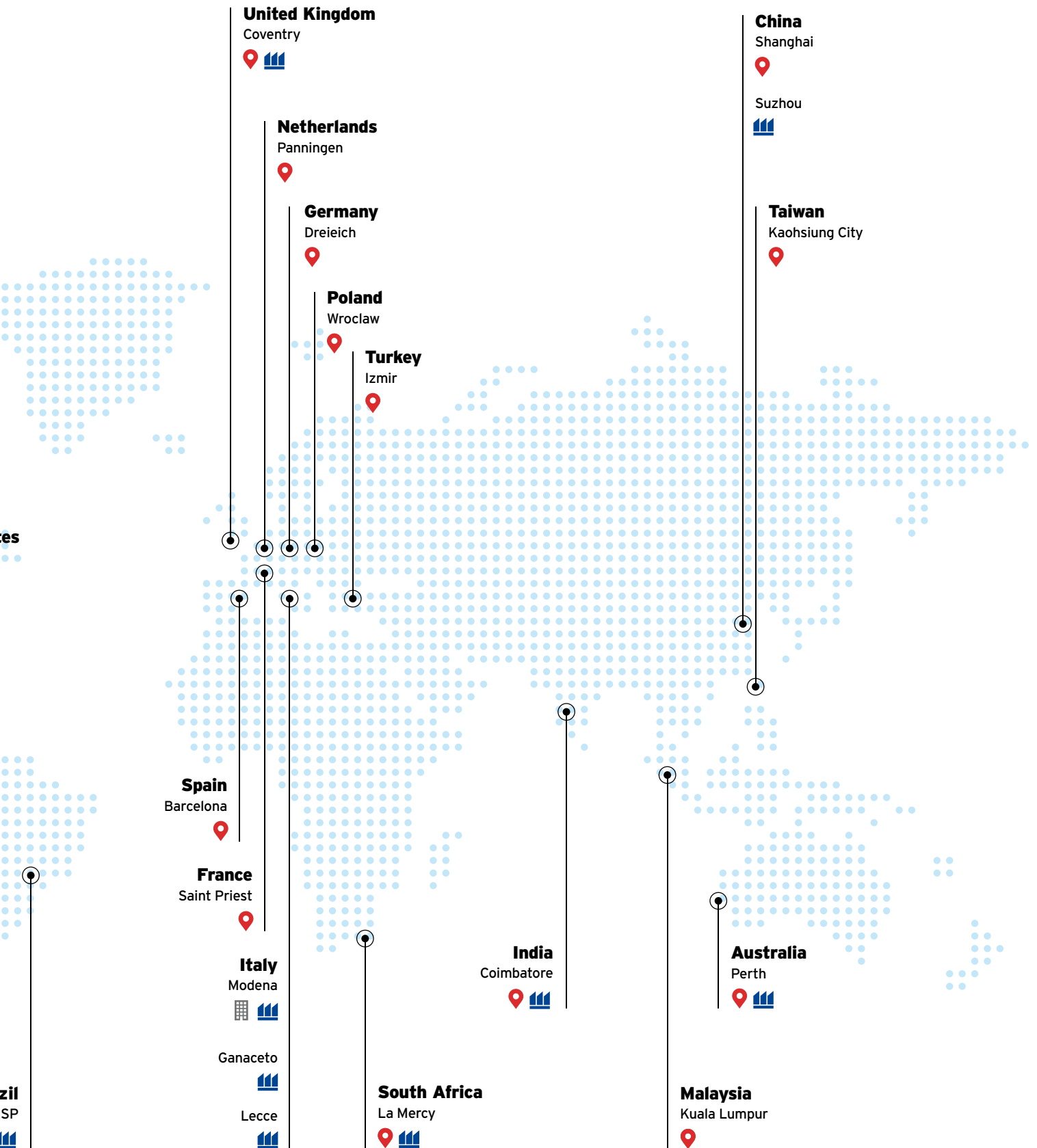

# Key figures



over **1,000** people around the world



**5,000** customers worldwide



**70** years of experience



**50** million euros investments in new technologies and methodologies to improve manufacturing efficiency



**18** affiliated companies



**5** production facilities



**8** assembly plants

## After-sale service



Highly trained mechanics and support teams can ensure a fast and efficient after-sale service providing support worldwide.



Our new space is your gateway to a world of information, assistance, and seamless access to the solutions you need. Whether you're an end user, distributor, or OEM partner you will find a personalized area to explore and manage all things related to your Rossi products.

Visit us at  
[www.rossi.com](http://www.rossi.com)



# Quality

## 3 years warranty\*



Our drive is to innovate and boost operations by manufacturing performing, precise, reliable and high-quality products all over the world. We are always one step forward in offering and developing solutions that can satisfy an unlimited number of application needs, even in the most demanding conditions.

\* As per our warranty terms.

## System certifications

ISO  
9001:2015

ISO  
14001:2015

ISO  
45001:2023

## Product certifications





Solutions for  
an evolving  
industry

**Rossi North America**  
3355 Martin Farm Road, Suite #400  
Suwanee, GA 30024

Phone - 1 800 931-2044  
Fax - 1 678- 288-3658

[info.northamerica@rossi.com](mailto:info.northamerica@rossi.com)  
[www.rossi.com/northamerica](http://www.rossi.com/northamerica)

© Rossi S.p.A. Rossi reserves the right to make any modification whenever to this publication contents. The information given in this document only contains general descriptions and/or performance features which may not always specifically reflect those described.

2623.BRO.RWT-24.04-0-US