

# BH series



**Motor bell housings**

[rossi.com](http://rossi.com)



# Contents

<b>1</b>	<b>General information</b>	<b>4</b>
	1.1 Design features	6
	1.2 Designation	7
	1.3 Assembly instructions	7
	1.4 Verifications	8
<b>2</b>	<b>Selection tables</b>	<b>10</b>
	2.1 Main dimensions	12
	R 2I motor bell housing for IEC standard motors	
	R 2I motor bell housing for NEMA standard motors	13
	R 3I motor bell housing for IEC standard motors	14
	R 3I motor bell housing for NEMA standard motors	15
	R CI motor bell housing for IEC standard motors	16
	R CI motor bell housing for NEMA standard motors	17
	R C2I motor bell housing for IEC standard motors	18
	R C2I motor bell housing for NEMA standard motors	19

1

# General information

## Section contents

1.1	Design features	6
1.2	Designation	7
1.3	Assembly instructions	7
1.4	Verifications	8

## 1.1

### Design features

#### General information

The scope of this catalog is to present our range of motor bell housings designed to fit Rossi G series helical and bevel helical gearboxes with motors.

The production planning includes the connection of electric motors with gear reducers by means of flexible coupling.

Connection available for:

- IEC standard electric motors, mounting position IM B5, from size 132 to size 315.
- NEMA standard electric motors, TC flange, from size N180TC to size N440TC

Connection available for gear reducers, helical and bevel helical type, from size 125 to size 360.

#### Available executions:

##### Helical gearboxes:

2I - 3I / UP2A std

2I - 3I / UP2D Consult us

##### Bevel helical gearboxes:

CI - C2I / UO2A std

CI - C2I / UO2V std

CI - C2I / UO2H std with BH fitted on extension 1

CI - C2I / UO2H std with BH fitted on extension 2

CI / UO2D std with BH fitted on extension 2

**BH bell housing not available** for following non-standard designs:

- Independent cooling fan (except double extension high speed shaft)
- ATEX design
- Labyrinth seals on high input shaft

**When selecting a gearbox with bell housing it is recommended to verify the service factor of the selected drives on the basis of motor power and motor speed and in accordance with gearbox nominal performances stated on G catalog.**

**To assure the proper reliability to the gearbox, according to the application, please consult instructions stated on Rossi G cat. Cap. 3 - Service factor.**

#### Housing

Housings are designed to deliver optimal strength and stiffness performance. They are equipped as standard with inspection windows to ensure high reliability.

They are made of nodular cast iron suitable for a range of temperature between -20°C and +50°C . It is also possible to supply solutions for environment conditions that exceed these values. In case please contact us.

#### Coupling

Flexible couplings are the standard solution provided.

Design temperature: -30°C / +50°C . We can also provide various types of couplings (geared, flexible all-steel, etc.) for applications with environmental conditions exceeding the aforementioned temperature limits, as well as for ATEX environments. Please contact us for more information.

#### BH 65×550

MOTOR FRAME	
(Ød × ØP) N180 ... N440 TC	IEC frame size 132 ... 315 NEMA frame size; TC = T shaft C flange
BELL HOUSING	

#### Housing

Thoroughly clean and degrease all mating surfaces. Screws class 8.8 or 10.9, where indicated, must be used to fit bell housing to the gearbox.



Use 10.9 screws tightened to the torque values specified for 8.8 screws. A torque wrench must be used. Do not apply lubricants that could alter the friction coefficient, as this may lead to overloading the screws. Always check the tightening torque after the first few hours of operation. Motor connection bolts are always included.

#### Coupling

It is crucial to ensure that the initial axial and radial alignment is as precise as possible. This will help accommodate changes in operating conditions and ensure the coupling's long-term reliability and trouble-free performance.

Assembly of "Half-coupling" motor side (in case of motor assembling not realized by Rossi) :

- Remove the rubber components.
- Connect the hub to the motor shaft using the spacer provided, placing it between the motor shaft shoulder and the coupling hub.

It is recommended to heat the hub (up to a maximum of 80°C) during assembly to facilitate installation.

- Re-assemble the rubber components.

To ensure reliable coupling performance, it is recommended to use electric motors with mating tolerances that meet the accuracy standards specified in IEC 60072-1.

For the assembly of non-standard couplings, feasibility must be verified. In such cases, please refer to the specific supplier documentation.

## 1.4

### Verifications

#### Maximum bending torque

Verify that the static bending torque ( $M_b$ ) generated by the motor weight on the counter flange of the gear reducer is lower than the maximum allowable value ( $M_{bmax}$ ) specified in the following pages:

$$M_b < M_{bmax}$$

where:

$$M_b = G \cdot (X + E) / 1\,000 \text{ [N m]}$$

G [N] motor weight; numerically nearly equal to motor mass, expressed in kg, multiplied by 10

X [mm] distance from motor center of gravity to motor flange surface

E [mm] supplied in the following pages, according to gear reducer and motor size

Very long and thin motors, even if their bending torques are within the prescribed limits, may generate abnormal vibrations during operation. In such cases, it is necessary to provide additional motor support as outlined in the motor's specific documentation.

Higher-than-permissible loads may occur in dynamic applications where the gearmotor is subjected to translation, rotation, or oscillation (e.g., shaft mounting arrangements). Please consult us for a detailed analysis of each specific case.

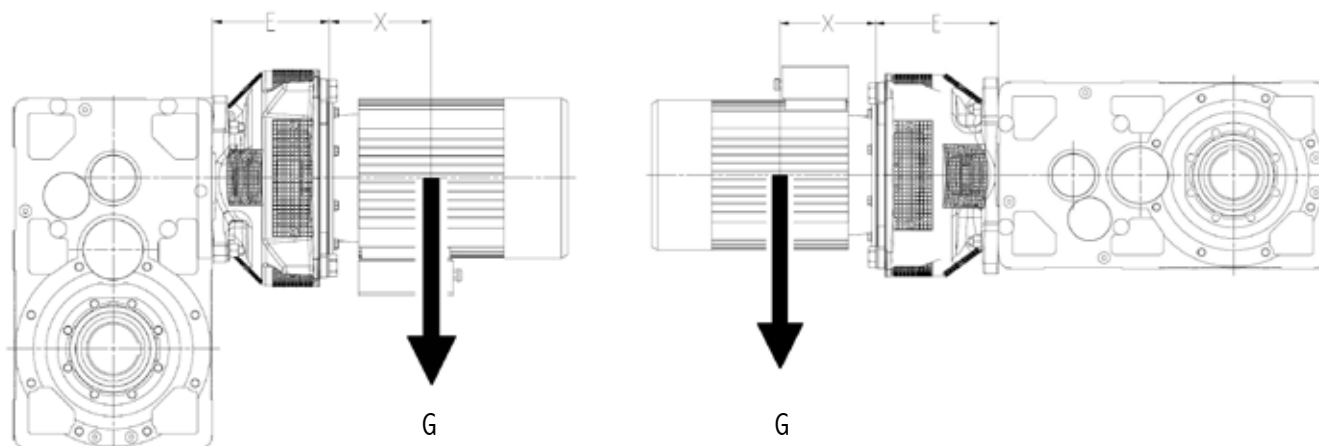

blank page

# Selection tables

## Section contents

2.1	Main dimensions	12
	R 2I motor bell housing for IEC standard motors	12
	R 2I motor bell housing for NEMA standard motors	13
	R 3I motor bell housing for IEC standard motors	14
	R 3I motor bell housing for NEMA standard motors	15
	R CI motor bell housing for IEC standard motors	16
	R CI motor bell housing for NEMA standard motors	17
	R C2I motor bell housing for IEC standard motors	18
	R C2I motor bell housing for NEMA standard motors	19

## 2.1

### Main dimensions

#### R 2I motor bell housing for IEC standard motors

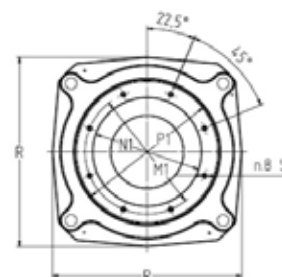
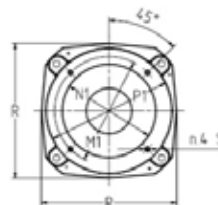
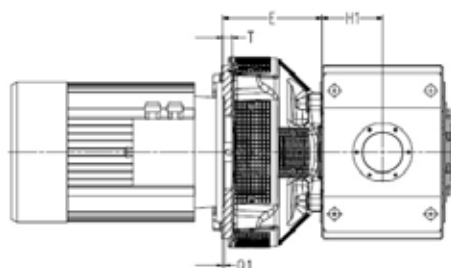

## 2I

160 ... 200

225 ... 315

Gear reducer size	Motor frame B5	E	P1 ∅	M1 ∅	N1 ∅ G7	Q1	T	S	R	M <sub>bmax</sub> N m 2)	Δm kg	Designation
140	160	230	360	300	250	6	34	M16	435	1500	52	BH42×350
	180	230	360	300	250	6	34	M16	435		52	BH48×350
	200	230	410	350	300	6	34	M16	435		52	BH55×400
	225	300	460	400	350	6	38	M16	610		110	BH60×450
160, 180	160	260	360	300	250	6	34	M16	435	3400	59	BH42×350
	180	260	360	300	250	6	34	M16	435		59	BH48×350
	200	260	410	350	300	6	34	M16	435		59	BH55×400
	225	300	460	400	350	6	38	M16	610		111	BH60×450
	250	300	560	500	450	6	38	M16	610		113	BH65×550
	280	300 <sup>1)</sup>	560	500	450	6	38	M16	610		119	BH75×550
200, 225	180	260	360	300	250	6	34	M16	435	6800	59	BH48×350
	200	260	410	350	300	6	34	M16	435		59	BH55×400
	225	320	460	400	350	6	38	M16	610		131	BH60×450
	250	320	560	500	450	6	38	M16	610		133	BH65×550
	280	320	560	500	450	6	38	M16	610		139	BH75×550
	315	352 <sup>1)</sup>	660	600	550	9	57	M22*	660		160	BH80×660 BH90×660
250, 280	225	320	460	400	350	6	38	M16	610	12000	131	BH60×450
	250	320	560	500	450	6	38	M16	610		133	BH65×550
	280	358	560	500	450	6	38	M16	610		160	BH75×550
	315	352	660	600	550	9	57	M22*	660		160	BH80×660 BH90×660
320, 321	280	358	560	500	450	6	38	M16	610	25000	160	BH75×550
	315	388	660	600	550	9	57	M22*	660		180	BH80×660 BH90×660
360	280	358	560	500	450	6	38	M16	610	25000	160	BH75×550
	315	388	660	600	550	9	57	M22*	660		180	BH80×660 BH90×660

\* Working length of thread 1.5 S.

1) Possible combination upon usable key length verification at shear and specific pressure.

2) Max bending torque page 8.

For available executions see page 6.

## R 2l motor bell housing for NEMA standard motors, T shaft, C flange

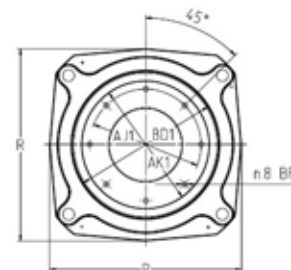
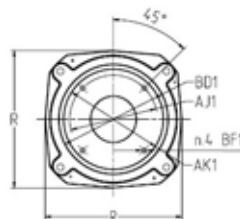
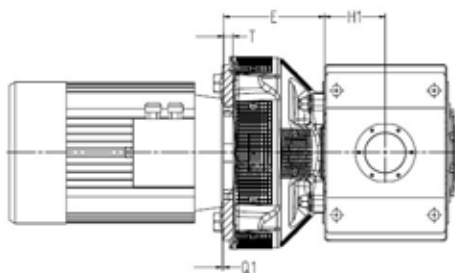

2l

N210TC ... 320TC

N360TC ... 440TC

Gear reducer size	NEMA motor frame	E	NEMA C-FACE Input side						R	$M_{bmax}$ N m 2)	$\Delta m$ kg	Designation
			BD1 $\varnothing$ in	AJ1 $\varnothing$ in	AK1 $\varnothing$ in G7	Q1 in	T in	BF1 in				
140	N210TC	213	9.251	7.25	8.5	0.213	0.614	0.551	335	1500	34	BHN210TC
	N250TC	230	9.251	7.25	8.5	0.213	1.339	0.551	435		58	BHN250TC
	N280TC	230	11.417	9	10.5	0.213	1.339	0.551	435		58	BHN280TC
	N320TC	230	-	11	12.5	0.213	1.339	0.669	435		58	BHN320TC
160, 180	N250TC	291	9.251	7.25	8.5	0.213	1.339	0.551	435	3400	58	BHN250TC
	N280TC	260	11.417	9	10.5	0.213	1.339	0.551	435		62	BHN280TC
	N320TC	291	-	11	12.5	0.213	1.339	0.669	435		58	BHN320TC
	N360TC	300 <sup>1)</sup>	15.945	11	12.5	0.213	1.496	0.669	610		123	BHN360TC
200, 225	N280TC	260	11.417	9	10.5	0.213	1.339	0.551	435	6800	62	BHN280TC
	N320TC	335	-	11	12.5	0.213	1.339	0.669	435		67	BHN320TC
	N360TC	320	15.945	11	12.5	0.213	1.496	0.669	610		143	BHN360TC
	N400TC	320	15.945	11	12.5	0.213	1.496	0.669	610		151	BHN400TC
250, 280	N360TC	320	15.945	11	12.5	0.213	1.496	0.669	610	12000	143	BHN360TC
	N400TC	358	15.945	11	12.5	0.213	1.496	0.669	610		172	BHN400TC
	N440TC	358	18.307	14	16	0.213	1.496	0.669	610		181	BHN440TC
320, 321	N400TC	461	15.945	11	12.5	0.213	1.496	0.669	610	25000	214	BHN400TC
	N440TC	461	18.307	14	16	0.213	1.496	0.669	610		221	BHN440TC
360	N400TC	461	15.945	11	12.5	0.213	1.496	0.669	610	25000	214	BHN400TC
	N440TC	461	18.307	14	16	0.213	1.496	0.669	610		221	BHN440TC

1) Possible combination upon usable key length verification at shear and specific pressure.

2) Max bending torque page 8.

For available executions see page 6.

## R 3I motor bell housing for IEC standard motors

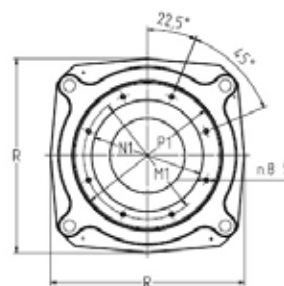
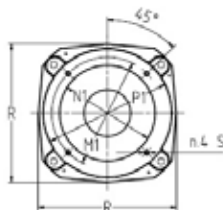
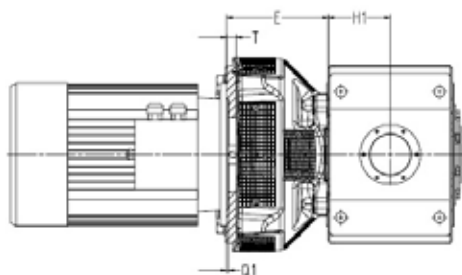

132 ... 200

225 ... 315

3I

Gear reducer size	Motor frame	E		P1	M1	N1	Q1	T	S	R	M <sub>bmax</sub>	Δm	Designation
		$i_N \leq 63$	$i_N \geq 71$	∅	∅	∅					N m	kg	
140	132	213	155	310	265	230	5	16	M12	335	1500	31	BH38×300
	160	230	-	360	300	250	6	34	M16	435		52	BH42×350
	180	230	-	360	300	250	6	34	M16	435		52	BH48×350
160, 180	160	230	230	360	300	250	6	34	M16	435	3400	52	BH42×350
	180	230	-	360	300	250	6	34	M16	435		52	BH48×350
	200	230	-	410	350	300	6	34	M16	435		52	BH55×400
	225	300	-	460	400	350	6	38	M16	610		110	BH60×450
200, 225	160	260	260	360	300	250	6	34	M16	435	6800	59	BH42×350
	180	260	260	360	300	250	6	34	M16	435		59	BH48×350
	200	260	260	410	350	300	6	34	M16	435		59	BH55×400
	225	320	-	460	400	350	6	38	M16	610		131	BH60×450
	250	320	-	560	500	450	6	38	M16	610		136	BH65×550
	280	320	-	560	500	450	6	38	M16	610		142	BH75×550
250, 280	200	270	270	410	350	300	6	34	M16	435	12000	80	BH55×400
	225	320	320	460	400	350	6	38	M16	610		131	BH60×450
	250	320	320	560	500	450	6	38	M16	610		133	BH65×550
	280	320	-	560	500	450	6	38	M16	610		139	BH75×550
	315	352 <sup>1)</sup>	-	660	600	550	9	57	M22*	660		159	BH80×660 BH90×660
320, 321	225	358	358	460	400	350	6	38	M16	610	25000	152	BH60×450
	250	358	358	560	500	450	6	38	M16	610		157	BH65×550
	280	358	358	560	500	450	6	38	M16	610		163	BH75×550
	315	390	390 <sup>1)</sup>	660	600	550	9	57	M22*	660		187	BH80×660 BH90×660
360	225	358	358	460	400	350	6	38	M16	610	25000	152	BH60×450
	250	358	358	560	500	450	6	38	M16	610		157	BH65×550
	280	358	358	560	500	450	6	38	M16	610		163	BH75×550
	315	390	390 <sup>1)</sup>	660	600	550	9	57	M22*	660		187	BH80×660 BH90×660

\* Working length of thread 1.5 S.

1) Possible combination upon usable key length verification at shear and specific pressure.

2) Max bending torque page 8.

For available executions see page 6.

## R 3I motor bell housing for NEMA standard motors, T shaft, C flange

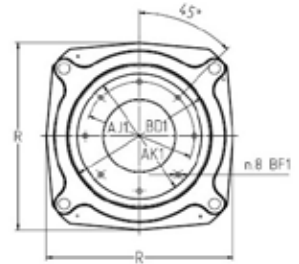
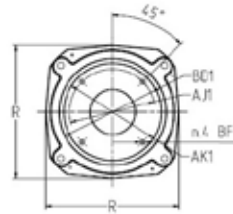
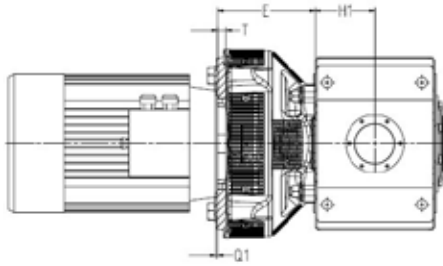

### 3I

N180TC ... 320TC

N360TC ... 440TC

Gear reducer size	NEMA motor frame	E		NEMA C-FACE Input side						R	M <sub>bmax</sub> N m 2)	Δm kg	Designation
		$i_N \leq 63$	$i_N \geq 71$	BD1	AJ1	AK1	Q1	T	BF1				
				∅ in	∅ in	∅ in G7	in	in	in				
140	N180TC	155	155	9.251	7.25	8.5	0.213	0.614	0.551	335	1500	30	BHN180TC
	N210TC	213	155	9.251	7.25	8.5	0.213	0.614	0.551	335		34	BHN210TC
	N250TC	230	-	9.251	7.25	8.5	0.213	1.339	0.551	435		58	BHN250TC
	N280TC	230	-	11.417	9	10.5	0.213	1.339	0.551	435		58	BHN280TC
160, 180	N180TC	-	155	9.251	7.25	8.5	0.213	0.614	0.551	335	3400	30	BHN180TC
	N210TC	213	213	9.251	7.25	8.5	0.213	0.614	0.551	335		34	BHN210TC
	N250TC	230	230	9.251	7.25	8.5	0.213	1.339	0.551	435		58	BHN250TC
	N280TC	230	230	11.417	9	10.5	0.213	1.339	0.551	435		58	BHN280TC
	N320TC	230	-	-	11	12.5	0.213	1.339	0.669	435		58	BHN320TC
	N360TC	300	-	15.945	11	12.5	0.213	1.496	0.669	610		124	BHN360TC
200, 225	N210TC	-	236	9.251	7.25	8.5	0.213	0.614	0.551	335	6800	41	BHN210TC
	N250TC	260	260	9.251	7.25	8.5	0.213	1.339	0.551	435		64	BHN250TC
	N280TC	260	260	11.417	9	10.5	0.213	1.339	0.551	435		64	BHN280TC
	N320TC	335	260	-	11	12.5	0.213	1.339	0.669	435		67	BHN320TC
	N360TC	320	-	15.945	11	12.5	0.213	1.496	0.669	610		143	BHN360TC
	N400TC	320	-	15.945	11	12.5	0.213	1.496	0.669	610		151	BHN400TC
250, 280	N250TC	-	270	9.251	7.25	8.5	0.213	1.339	0.551	435	12000	84	BHN250TC
	N280TC	270	270	11.417	9	10.5	0.213	1.339	0.551	435		84	BHN280TC
	N320TC	270	270	-	11	12.5	0.213	1.339	0.669	435		84	BHN320TC
	N360TC	320	320	15.945	11	12.5	0.213	1.496	0.669	610		143	BHN360TC
	N400TC	320	320	15.945	11	12.5	0.213	1.496	0.669	610		151	BHN400TC
	N440TC	358 <sup>1)</sup>	-	18.307	14	16	0.213	1.496	0.669	610		181	BHN440TC
320, 321	N320TC	346	270	-	11	12.5	0.213	1.339	0.669	435	25000	98	BHN320TC
	N360TC	358	358	15.945	11	12.5	0.213	1.496	0.669	610		164	BHN360TC
	N400TC	358	358	15.945	11	12.5	0.213	1.496	0.669	610		181	BHN400TC
	N440TC	358	358 <sup>1)</sup>	18.307	14	16	0.213	1.496	0.669	610		181	BHN440TC
360	N320TC	346	270	-	11	12.5	0.213	1.339	0.669	435	25000	98	BHN320TC
	N360TC	358	358	15.945	11	12.5	0.213	1.496	0.669	610		164	BHN360TC
	N400TC	358	358	15.945	11	12.5	0.213	1.496	0.669	610		181	BHN400TC
	N440TC	358	358 <sup>1)</sup>	18.307	14	16	0.213	1.496	0.669	610		181	BHN440TC

1) Valid for motor 447/9TC - Possible combination upon usable key length verification at shear and specific pressure.

2) Max bending torque page 8.

For available executions see page 6.

## R CI motor bell housing for IEC standard motors

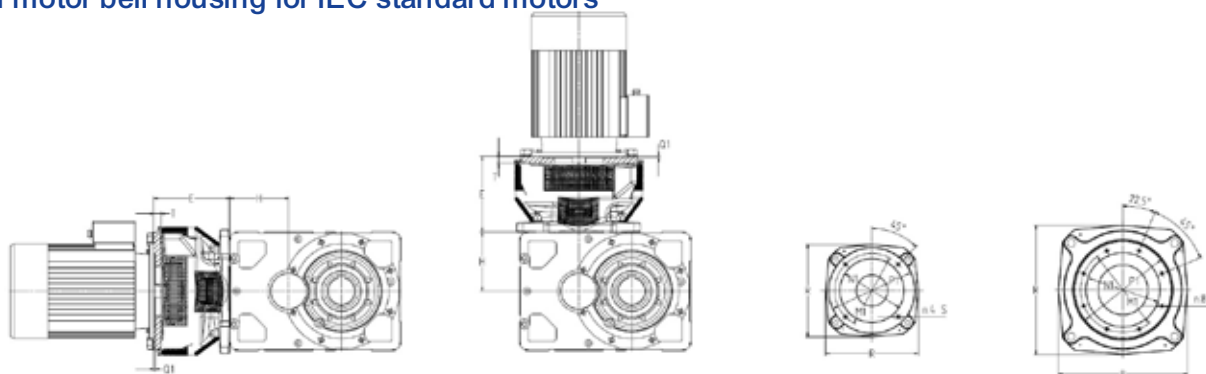

### CI

132 ... 200

225 ... 315

Gear reducer size	Motor frame	E						P1 ø	M1 ø	N1 ø	Q1	T	S	R	M <sub>bmax</sub> N m 2)	Δm kg	Designation
		UO2A / UO2A sin 3)			UO2V / UO2V sin 3)												
125	132	$i_N \leq 8$	$9 \leq i_N \leq 16$	$i_N \geq 18$	$i_N \leq 8$	$9 \leq i_N \leq 16$	$i_N \geq 18$	310	265	230	5	16	M12	335	1500	31	BH38×300
	160	291	230	230	291	230	230	360	300	250	6	34	M16	435		52	BH42×350
	180	291	230	230	291	230	230	360	300	250	6	34	M16	435		52	BH48×350
	200	291	230 <sup>1)</sup>	-	291	230 <sup>1)</sup>	-	410	350	300	6	34	M16	435		52	BH55×400
140	132	$i_N \leq 9$	$10 \leq i_N \leq 16$	$i_N \geq 18$	$i_N \leq 9$	$10 \leq i_N \leq 16$	$i_N \geq 18$	310	265	230	5	16	M12	335	1500	31	BH38×300
	160	291	230	230	291	230	230	360	300	250	6	34	M16	435		52	BH42×350
	180	291	230	230	291	230	230	360	300	250	6	34	M16	435		52	BH48×350
	200	291	230 <sup>1)</sup>	-	291	230 <sup>1)</sup>	-	410	350	300	6	34	M16	435		52	BH55×400
160	160	$i_N \leq 8$	$9 \leq i_N \leq 16$	$i_N \geq 18$	$i_N \leq 8$	$9 \leq i_N \leq 16$	$i_N \geq 18$	360	300	250	6	34	M16	435	3400	52	BH42×350
	180	291	291	291	291	291	291	360	300	250	6	34	M16	435		52	BH48×350
	200	335	291	260	335	291	260	410	350	300	6	34	M16	435		65	BH55×400
	225	422	300	300	422	300	300	460	400	350	6	38	M16	610		137	BH60×450
180	160	$i_N \leq 9$	$10 \leq i_N \leq 16$	$i_N \geq 18$	$i_N \leq 9$	$10 \leq i_N \leq 16$	$i_N \geq 18$	360	300	250	6	34	M16	435	3400	52	BH42×350
	180	291	291	291	291	291	291	360	300	250	6	34	M16	435		52	BH48×350
	200	335	291	260	335	291	260	410	350	300	6	34	M16	435		65	BH55×400
	225	422	300	300	422	300	300	460	400	350	6	38	M16	610		137	BH60×450
200	160	$i_N \leq 8$	$9 \leq i_N \leq 16$	$i_N \geq 18$	$i_N \leq 8$	$9 \leq i_N \leq 16$	$i_N \geq 18$	360	300	250	6	34	M16	435	6800	65	BH42×350
	180	-	-	335	-	-	335	360	300	250	6	34	M16	435		65	BH48×350
	200	-	335	335	-	335	335	410	350	300	6	34	M16	435		65	BH55×400
	225	-	422	320	-	422	320	460	400	350	6	38	M16	610		137	BH60×450
	250	422	422	320	422	422	320	560	500	450	6	38	M16	610		144	BH65×550
	280	422	320	320 <sup>1)</sup>	422	320	320 <sup>1)</sup>	560	500	450	6	38	M16	610		150	BH75×550
225	160	$i_N \leq 9$	$10 \leq i_N \leq 16$	$i_N \geq 18$	$i_N \leq 9$	$10 \leq i_N \leq 16$	$i_N \geq 18$	360	300	250	6	34	M16	435	6800	65	BH42×350
	180	-	-	335	-	-	335	360	300	250	6	34	M16	435		65	BH48×350
	200	-	335	335	-	335	335	410	350	300	6	34	M16	435		65	BH55×400
	225	-	422	320	-	422	320	460	400	350	6	38	M16	610		137	BH60×450
	250	422	422	320	422	422	320	560	500	450	6	38	M16	610		144	BH65×550
	280	422	320	320 <sup>1)</sup>	422	320	320 <sup>1)</sup>	560	500	450	6	38	M16	610		150	BH75×550
250	200	$i_N \leq 10$	$11,2 \leq i_N \leq 16$	$i_N \geq 18$	$i_N \leq 10$	$11,2 \leq i_N \leq 16$	$i_N \geq 18$	410	350	300	6	34	M16	435	12000	91	BH55×400
	225	-	-	346	-	-	346	460	400	350	6	38	M16	610		153	BH60×450
	250	-	358	358	-	358	358	560	500	450	6	38	M16	610		153	BH65×550
	280	461	358	358	461	358	358	560	500	450	6	38	M16	610		160	BH75×550
	315	493	390 <sup>1)</sup>	390 <sup>1)</sup>	493	390 <sup>1)</sup>	390 <sup>1)</sup>	660	600	550	9	57	M22*	660		180	BH80×660 BH90×660
280	200	$i_N \leq 11,2$	$12,5 \leq i_N \leq 16$	$i_N \geq 18$	$i_N \leq 11,2$	$12,5 \leq i_N \leq 16$	$i_N \geq 18$	410	350	300	6	34	M16	435	12000	91	BH55×400
	225	-	-	346	-	-	346	460	400	350	6	38	M16	610		153	BH60×450
	250	-	358	358	-	358	358	560	500	450	6	38	M16	610		153	BH65×550
	280	461	358	358	461	358	358	560	500	450	6	38	M16	610		160	BH75×550
	315	493	390 <sup>1)</sup>	390 <sup>1)</sup>	493	390 <sup>1)</sup>	390 <sup>1)</sup>	660	600	550	9	57	M22*	660		180	BH80×660 BH90×660
320, 321	280	$i_N \leq 10$	$11,2 \leq i_N \leq 16$	$i_N \geq 18$	$i_N \leq 10$	$11,2 \leq i_N \leq 16$	$i_N \geq 18$	560	500	450	6	38	M16	610	25000	200	BH75×550
	315	493	493	493	493	493	493	660	600	550	9	57	M22*	660		227	BH80×660 BH90×660
360	280	$i_N \leq 11,2$	$12,5 \leq i_N \leq 16$	$i_N \geq 18$	$i_N \leq 11,2$	$12,5 \leq i_N \leq 16$	$i_N \geq 18$	560	500	450	6	38	M16	610	25000	200	BH75×550
	315	493	493	493	493	493	493	660	600	550	9	57	M22*	660		227	BH80×660 BH90×660

## R CI motor bell housing for NEMA standard motors, T shaft, C flange

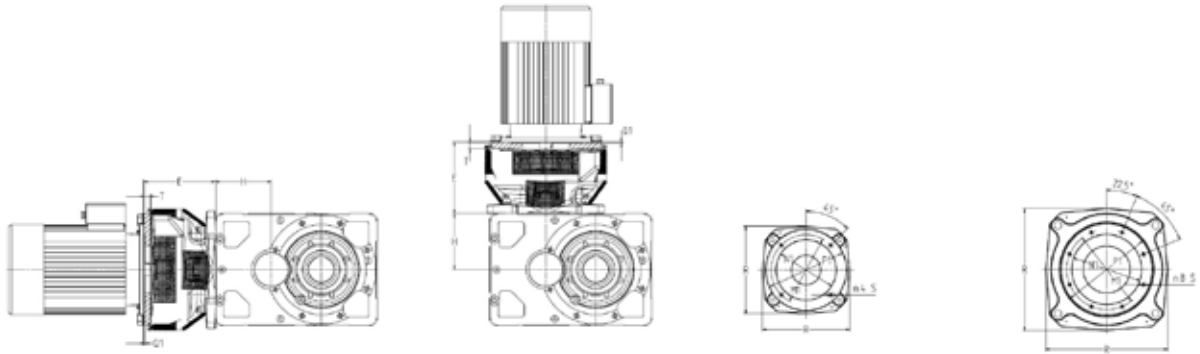

### CI

### N180TC ... 320TC

### N360TC ... 440TC

Gear reducer size	NEMA motor frame	E						NEMA C-FACE Input side						R	M <sub>bmax</sub> N m 3)	Δm kg	Designation	
		UO2A / UO2A sin 4)			UO2V / UO2V sin 4)			BD1	AJ1	AK1	Q1	T	BF1					
		i <sub>N</sub> ≤ 8	9 ≤ i <sub>N</sub> ≤ 16	i <sub>N</sub> ≥ 18	i <sub>N</sub> ≤ 8	9 ≤ i <sub>N</sub> ≤ 16	i <sub>N</sub> ≥ 18	∅ in	∅ in	∅ G7 in	in	in	in					
125	N180TC	i <sub>N</sub> ≤ 8	9 ≤ i <sub>N</sub> ≤ 16	i <sub>N</sub> ≥ 18	i <sub>N</sub> ≤ 8	9 ≤ i <sub>N</sub> ≤ 16	i <sub>N</sub> ≥ 18	9.251	7.25	8.5	0.213	0.614	0.551	335	1500	34	BHN180TC	
	N210TC	-	213	213	-	213	213	9.251	7.25	8.5	0.213	0.614	0.551				34	BHN210TC
	N250TC	291	230	230	291	230	230	9.251	7.25	8.5	0.213	1.339	0.551				58	BHN250TC
	N280TC	291	291	291	291	291	291	11.417	9	10.5	0.213	1.339	0.551				58	BHN280TC
	N320TC	291	291 <sup>1)</sup>	-	291	291 <sup>1)</sup>	-	-	11	12.5	0.213	1.339	0.669				58	BHN320TC
140	N180TC	i <sub>N</sub> ≤ 9	10 ≤ i <sub>N</sub> ≤ 16	i <sub>N</sub> ≥ 18	i <sub>N</sub> ≤ 9	10 ≤ i <sub>N</sub> ≤ 16	i <sub>N</sub> ≥ 18	9.251	7.25	8.5	0.213	0.614	0.551	335	1500	34	BHN180TC	
	N210TC	-	213	213	-	213	213	9.251	7.25	8.5	0.213	0.614	0.551				34	BHN210TC
	N250TC	291	230	230	291	230	230	9.251	7.25	8.5	0.213	1.339	0.551				58	BHN250TC
	N280TC	291	291	291	291	291	291	11.417	9	10.5	0.213	1.339	0.551				58	BHN280TC
	N320TC	291	291 <sup>1)</sup>	-	291	291 <sup>1)</sup>	-	-	11	12.5	0.213	1.339	0.669				58	BHN320TC
160	N210TC	i <sub>N</sub> ≤ 8	9 ≤ i <sub>N</sub> ≤ 16	i <sub>N</sub> ≥ 18	i <sub>N</sub> ≤ 8	9 ≤ i <sub>N</sub> ≤ 16	i <sub>N</sub> ≥ 18	9.251	7.25	8.5	0.213	0.614	0.551	335	3400	41	BHN210TC	
	N250TC	-	-	236	-	-	236	9.251	7.25	8.5	0.213	1.339	0.551				435	BHN250TC
	N280TC	-	291	291	-	291	291	11.417	9	10.5	0.213	1.339	0.551				435	BHN280TC
	N320TC	335	291	335	335	291	335	-	11	12.5	0.213	1.339	0.669				435	BHN320TC
	N360TC	422	300	300	422	300	300	15.945	11	12.5	0.213	1.496	0.669				610	BHN360TC
180	N210TC	i <sub>N</sub> ≤ 9	10 ≤ i <sub>N</sub> ≤ 16	i <sub>N</sub> ≥ 18	i <sub>N</sub> ≤ 9	10 ≤ i <sub>N</sub> ≤ 16	i <sub>N</sub> ≥ 18	9.251	7.25	8.5	0.213	0.614	0.551	335	3400	41	BHN210TC	
	N250TC	-	-	236	-	-	236	9.251	7.25	8.5	0.213	1.339	0.551				435	BHN250TC
	N280TC	-	291	291	-	291	291	11.417	9	10.5	0.213	1.339	0.551				435	BHN280TC
	N320TC	335	291	335	335	291	335	-	11	12.5	0.213	1.339	0.669				435	BHN320TC
	N360TC	422	300	300	422	300	300	15.945	11	12.5	0.213	1.496	0.669				610	BHN360TC
200	N250TC	i <sub>N</sub> ≤ 8	9 ≤ i <sub>N</sub> ≤ 16	i <sub>N</sub> ≥ 18	i <sub>N</sub> ≤ 8	9 ≤ i <sub>N</sub> ≤ 16	i <sub>N</sub> ≥ 18	9.251	7.25	8.5	0.213	1.339	0.551	435	6800	64	BHN250TC	
	N280TC	-	-	335	-	-	335	11.417	9	10.5	0.213	1.339	0.551				435	BHN280TC
	N320TC	-	335	335	-	335	335	-	11	12.5	0.213	1.339	0.669				435	BHN320TC
	N360TC	-	422	320	-	422	320	15.945	11	12.5	0.213	1.496	0.669				610	BHN360TC
	N400TC	422	422	320	422	422	320	15.945	11	12.5	0.213	1.496	0.669				610	BHN400TC
225	N250TC	i <sub>N</sub> ≤ 9	10 ≤ i <sub>N</sub> ≤ 16	i <sub>N</sub> ≥ 18	i <sub>N</sub> ≤ 9	10 ≤ i <sub>N</sub> ≤ 16	i <sub>N</sub> ≥ 18	9.251	7.25	8.5	0.213	1.339	0.551	435	6800	64	BHN250TC	
	N280TC	-	-	335	-	-	335	11.417	9	10.5	0.213	1.339	0.551				435	BHN280TC
	N320TC	-	335	335	-	335	335	-	11	12.5	0.213	1.339	0.669				435	BHN320TC
	N360TC	-	422	320	-	422	320	15.945	11	12.5	0.213	1.496	0.669				610	BHN360TC
	N400TC	422	422	320	422	422	320	15.945	11	12.5	0.213	1.496	0.669				610	BHN400TC
250	N320TC	i <sub>N</sub> ≤ 10	11,2 ≤ i <sub>N</sub> ≤ 16	i <sub>N</sub> ≥ 18	i <sub>N</sub> ≤ 10	11,2 ≤ i <sub>N</sub> ≤ 16	i <sub>N</sub> ≥ 18	-	11	12.5	0.213	1.339	0.669	435	12000	94	BHN320TC	
	N360TC	-	-	461	-	-	461	15.945	11	12.5	0.213	1.496	0.669				610	BHN360TC
	N400TC	-	461	461	-	461	461	15.945	11	12.5	0.213	1.496	0.669				610	BHN400TC
	N440TC	461	461 <sup>1)2)</sup>	461 <sup>1)2)</sup>	461	461 <sup>1)2)</sup>	461 <sup>1)2)</sup>	18.307	14	16	0.213	1.496	0.669				610	BHN440TC
	N320TC	i <sub>N</sub> ≤ 11,2	12,5 ≤ i <sub>N</sub> ≤ 16	i <sub>N</sub> ≥ 18	i <sub>N</sub> ≤ 11,2	12,5 ≤ i <sub>N</sub> ≤ 16	i <sub>N</sub> ≥ 18	-	11	12.5	0.213	1.339	0.669				435	12000
N360TC	-	-	461	-	-	461	15.945	11	12.5	0.213	1.496	0.669	610	BHN360TC				
N400TC	-	461	461	-	461	461	15.945	11	12.5	0.213	1.496	0.669	610	BHN400TC				
N440TC	461	461 <sup>1)2)</sup>	461 <sup>1)2)</sup>	461	461 <sup>1)2)</sup>	461 <sup>1)2)</sup>	18.307	14	16	0.213	1.496	0.669	610	BHN440TC				
320, 321	N440TC	i <sub>N</sub> ≤ 10	11,2 ≤ i <sub>N</sub> ≤ 16	i <sub>N</sub> ≥ 18	i <sub>N</sub> ≤ 10	11,2 ≤ i <sub>N</sub> ≤ 16	i <sub>N</sub> ≥ 18	18.307	14	16	0.213	1.496	0.669	610	25000	239	BHN440TC	
	N440TC	556	556	556	556	556	556	18.307	14	16	0.213	1.496	0.669				610	25000
360	N440TC	i <sub>N</sub> ≤ 11,2	12,5 ≤ i <sub>N</sub> ≤ 16	i <sub>N</sub> ≥ 18	i <sub>N</sub> ≤ 11,2	12,5 ≤ i <sub>N</sub> ≤ 16	i <sub>N</sub> ≥ 18	18.307	14	16	0.213	1.496	0.669	610	25000	239	BHN440TC	

Notes of page 16:

\*) Working length of thread 15 · S.

1) Possible combination upon usable key length verification at shear and specific pressure.

2) Max bending torque see page 8.

3) For available executions see page 6.

Notes of page 17:

1) Possible combination upon usable key length verification at shear and specific pressure.

2) Verification valid for motor 447/9TC.

3) Max bending torque see page 8.

4) For available executions see page 6.

## R C2I motor bell housing for IEC standard motors

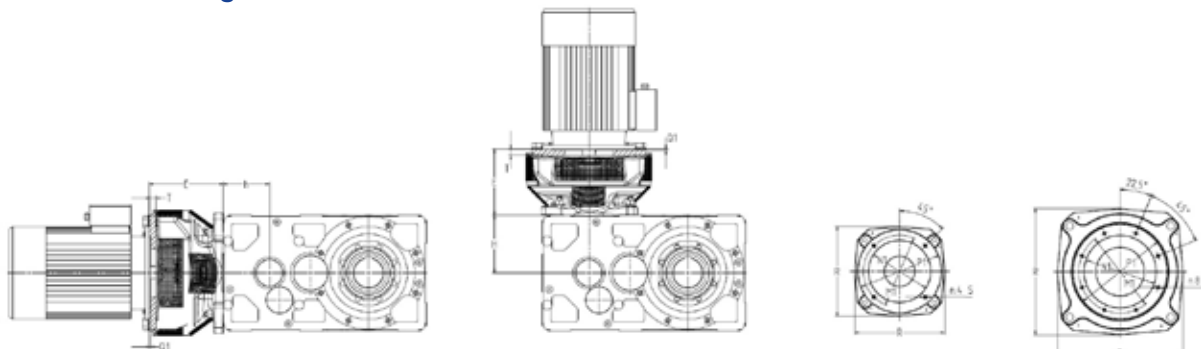

### C2I

132 ... 200

225 ... 315

Gear reducer size	Motor frame	E						P ∅	M ∅	N ∅ G7	Q	T	S	R	M <sub>bmax</sub> N m 2)	Δm kg	Designation
		UO2A / UO2A sin 3)			UO2V / UO2V sin 3)												
		i <sub>N</sub> ≤ 31,5	35,5 ≤ i <sub>N</sub> ≤ 63	i <sub>N</sub> ≥ 71	i <sub>N</sub> ≤ 31,5	35,5 ≤ i <sub>N</sub> ≤ 63	i <sub>N</sub> ≥ 71										
140	132	213	213	213	213	155	155	310	265	230	5	16	M12	335	1500	31	BH38×300
	160	230	230	-	230	230	-	360	300	250	6	34	M16	435	52	BH42×350	
	180	230	-	-	230	-	-	360	300	250	6	34	M16	435	52	BH48×350	
160, 180	160	291	260	230	260	230	230	360	300	250	6	34	M16	435	3400	59	BH42×350
	180	291	260	-	260	230	-	360	300	250	6	34	M16	435		59	BH48×350
	200	291	230 <sup>1)</sup>	-	260	230 <sup>1)</sup>	-	410	350	300	6	34	M16	435		59	BH55×400
	225	300	-	-	300	-	-	460	400	350	6	38	M16	610		111	BH60×450
200, 225	160	335	260	260	335	260	260	360	300	250	6	34	M16	435	6800	65	BH42×350
	180	335	260	260	335	260	260	360	300	250	6	34	M16	435		65	BH48×350
	200	335	260	260	335	260	260	410	350	300	6	34	M16	435		65	BH55×400
	225	422	320	-	320	320	-	460	400	350	6	38	M16	610		137	BH60×450
	250	422	320	-	320	320	-	560	500	450	6	38	M16	610		144	BH65×550
	280	422	-	-	320	-	-	560	500	450	6	38	M16	610		150	BH75×550
250, 280	200	-	346	270	-	270	270	410	350	300	6	34	M16	435	12000	91	BH55×400
	225	358	358	320	320	320	320	460	400	350	6	38	M16	610		153	BH60×450
	250	358	358	320	320	320	320	560	500	450	6	38	M16	610		153	BH65×550
	280	358	320	-	320	320	-	560	500	450	6	38	M16	610		160	BH75×550
	315	390 <sup>1)</sup>	352 <sup>1)</sup>	-	352 <sup>1)</sup>	352 <sup>1)</sup>	-	660	600	550	9	57	M22*	660		180	BH80×660 BH90×660
320, 321	225	-	358	358	-	358	358	460	400	350	6	38	M16	610	25000	152	BH60×450
	250	461	358	358	358	358	358	560	500	450	6	38	M16	610		193	BH65×550
	280	461	358	358	358	358	358	560	500	450	6	38	M16	610		200	BH75×550
	315	493	390 <sup>1)</sup>	390 <sup>1)</sup>	390	390 <sup>1)</sup>	390 <sup>1)</sup>	660	600	550	9	57	M22*	660		227	BH80×660 BH90×660
360	225	-	358	358	-	358	358	460	400	350	6	38	M16	610	25000	152	BH60×450
	250	461	358	358	358	358	358	560	500	450	6	38	M16	610		193	BH65×550
	280	461	358	358	358	358	358	560	500	450	6	38	M16	610		200	BH75×550
	315	493	390 <sup>1)</sup>	390 <sup>1)</sup>	390	390 <sup>1)</sup>	390 <sup>1)</sup>	660	600	550	9	57	M22*	660		227	BH80×660 BH90×660

\*) Working length of thread 1.5 S.

1) Possible combination upon usable key length verification at shear and specific pressure.

2) Max bending torque see page 8.

3) For available executions see page 6.

## R C2I motor bell housing for NEMA standard motors, T shaft, C flange

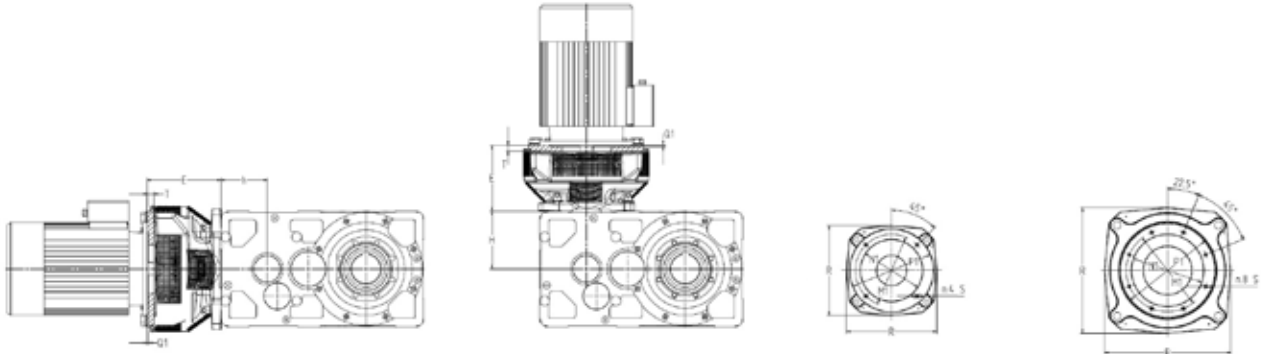

C2I

N180TC ... 320TC

N360TC ... 440TC

Gear reducer size	NEMA motor frame	E						NEMA C-FACE Input side						R	M <sub>bmax</sub> N m 3)	Δm kg	Designation
		UO2A / UO2A sin 4)			UO2V / UO2V sin 4)			BD1	AJ1	AK1	Q1	T	BF1				
		i <sub>N</sub> ≤ 31,5	35,5 ≤ i <sub>N</sub> ≤ 63	i <sub>N</sub> ≥ 71	i <sub>N</sub> ≤ 31,5	35,5 ≤ i <sub>N</sub> ≤ 63	i <sub>N</sub> ≥ 71	∅ in	∅ in	∅ in G7	in	in	in				
140	N180TC	-	155	155	-	155	155	9.251	7.25	8.5	0.213	0.614	0.551	335	1500	30	BHN180TC
	N210TC	213	213	155	213	155	155	9.251	7.25	8.5	0.213	0.614	0.551	335		34	BHN210TC
	N250TC	291	230	-	230	230	-	9.251	7.25	8.5	0.213	1.339	0.551	435		58	BHN250TC
	N280TC	291	-	-	230	-	-	11.417	9	10.5	0.213	1.339	0.551	435		58	BHN280TC
160, 180	N180TC	-	-	213	-	-	155	9.251	7.25	8.5	0.213	0.614	0.551	335	3400	34	BHN180TC
	N210TC	-	213	213	-	213	155	9.251	7.25	8.5	0.213	0.614	0.551	335		34	BHN210TC
	N250TC	260	230	230	130	230	230	9.251	7.25	8.5	0.213	1.339	0.551	435		64	BHN250TC
	N280TC	291	260	-	260	230	-	11.417	9	10.5	0.213	1.339	0.551	435		64	BHN280TC
	N320TC	291	291 <sup>1)</sup>	-	260	291 <sup>1)</sup>	-	-	11	12.5	0.213	1.339	0.669	435		64	BHN320TC
200, 225	N210TC	-	-	236	-	-	236	9.251	7.25	8.5	0.213	0.614	0.551	335	6800	41	BHN210TC
	N250TC	-	260	260	-	260	260	9.251	7.25	8.5	0.213	1.339	0.551	435		64	BHN250TC
	N280TC	335	335	335	335	260	260	11.417	9	10.5	0.213	1.339	0.551	435		69	BHN280TC
	N320TC	335	335	335	335	260	260	-	11	12.5	0.213	1.339	0.669	435		69	BHN320TC
	N360TC	422	320	-	320	320	-	15.945	11	12.5	0.213	1.496	0.669	610		151	BHN360TC
	N400TC	422	-	-	422	-	-	15.945	11	12.5	0.213	1.496	0.669	610		161	BHN400TC
250, 280	N250TC	-	-	270	-	-	270	9.251	7.25	8.5	0.213	1.339	0.551	435	12000	86	BHN250TC
	N280TC	-	346	346	-	270	270	11.417	9	10.5	0.213	1.339	0.551	435		94	BHN280TC
	N320TC	-	346	346	-	270	270	-	11	12.5	0.213	1.339	0.669	435		94	BHN320TC
	N360TC	461	358	320	320	320	320	15.945	11	12.5	0.213	1.496	0.669	610		204	BHN360TC
	N400TC	461	461	320	358	358	320	15.945	11	12.5	0.213	1.496	0.669	610		214	BHN400TC
	N440TC	461 <sup>1)2)</sup>	461 <sup>1)2)</sup>	-	358 <sup>1)2)</sup>	358 <sup>1)2)</sup>	-	18.307	14	16	0.213	1.496	0.669	610		221	BHN440TC
320, 321	N320TC	-	346	346	-	270	270	-	11	12.5	0.213	1.339	0.669	435	25000	94	BHN320TC
	N360TC	-	461	461	-	358	358	15.945	11	12.5	0.213	1.496	0.669	610		204	BHN360TC
	N400TC	461	461	461	461	358	358	15.945	11	12.5	0.213	1.496	0.669	610		214	BHN400TC
	N440TC	461	461 <sup>1)2)</sup>	461 <sup>1)2)</sup>	461	358 <sup>1)2)</sup>	358 <sup>1)2)</sup>	18.307	14	16	0.213	1.496	0.669	610		221	BHN440TC
360	N320TC	-	346	346	-	270	270	-	11	12.5	0.213	1.339	0.669	435	25000	94	BHN320TC
	N360TC	-	461	461	-	358	358	15.945	11	12.5	0.213	1.496	0.669	610		204	BHN360TC
	N400TC	461	461	461	461	358	358	15.945	11	12.5	0.213	1.496	0.669	610		214	BHN400TC
	N440TC	461	461 <sup>1)2)</sup>	461 <sup>1)2)</sup>	461	358 <sup>1)2)</sup>	358 <sup>1)2)</sup>	18.307	14	16	0.213	1.496	0.669	610		221	BHN440TC

1) Possible combination upon usable key length verification at shear and specific pressure.

2) Verification valid for motor 447/9TC.

3) Max bending torque page 8.

4) For available executions see page 6.



# Rossi

Solutions for  
an evolving  
industry

**Rossi S.p.A.**

Via Emilia Ovest 915/A  
41123 Modena - Italy

[info@rossi.com](mailto:info@rossi.com)  
[www.rossi.com](http://www.rossi.com)

2651.CAT.BH--25.12-0-EN

© Rossi S.p.A. Rossi reserves the right to make any modification whenever to this publication contents. The information given in this document only contains general descriptions and/or performance features which may not always specifically reflect those described.

The Customer is responsible for the correct selection and application of product in view of its industrial and/or commercial needs, unless the use has been recommended by technical qualified personnel of Rossi, who were duly informed about Customer's application purposes. In this case all the necessary data required for the selection shall be communicated exactly and in writing by the Customer, stated in the order and confirmed by Rossi. The Customer is always responsible for the safety of product applications. Every care has been taken in the drawing up of the catalog to ensure the accuracy of the information contained in this publication, however Rossi can accept no responsibility for any errors, omissions or outdated data. Due to the constant evolution of the state of the art, Rossi reserves the right to make any modification whenever to this publication contents. The responsibility for the product selection is of the Customer, excluding different agreements duly legalized in writing and undersigned by the Parties.