

TX series



**Asynchronous three-phase standard
and brake motors**





Contents

1	Rossi for You	6
	1.1 Global presence local service	8
2	Product overview	10
	2.1 Features, benefits and range	12
	2.2 Asynchronous three-phase motors, brake motors	14
	2.3 Symbols and units of measure	18
	2.4 Energy efficiency classes	19
	2.5 Duty types	20
	2.6 Verifying and evaluating calculations	20
	2.7 Variations of nominal specifications	21
	2.8 Sound levels	22
	2.9 Running with inverter	22
	2.10 Tolerances	27
	2.11 Specific standards	28
	2.12 Regulations to standard 2012/19/EU	28
3	Asynchronous three-phase motor HB	30
	3.1 General specifications	32
	3.2 Designation	32
	3.3 Specifications	33
	3.4 Radial and axial loads on shaft end	36
	3.5 Technical data 400V 50 Hz	38
	3.6 Technical data 230.460V 60 Hz	44
	3.7 Technical data 380V 60 Hz	48
	3.8 Technical data 400V 50 Hz	50
	3.9 Motor dimensions	54
	3.10 Non-standard designs and accessories	57
	3.11 Name plate	68
	3.12 Standard supply voltage	69

4	Brake motor for gearmotors HBZ	70
4.1	General specifications	72
4.2	Designation	73
4.3	Specifications	73
4.4	Radial and axial loads on shaft end	77
4.5	Motor brake specifications	78
4.6	Technical data 400V 50 Hz	80
4.7	Technical data 230.460V 60 Hz	86
4.8	Technical data 380V 60 Hz	90
4.9	Motor dimensions	92
4.10	Non-standard designs and accessories	95
4.11	Name plate	107
4.12	Standard voltage/frequency on name plate	108
5	Brake motor for specific applications HBF	110
5.1	General specifications	112
5.2	Designation	113
5.3	Specifications	113
5.4	Radial and axial loads on shaft end	117
5.5	Motor brake specifications	118
5.6	Technical data 400V 50 Hz	121
5.7	Technical data 230.460V 60 Hz	126
5.8	Technical data 380V 60 Hz	130
5.9	Motor dimensions	132
5.10	Non-standard designs and accessories	135
5.11	Name plate	144
5.12	Standard voltage/frequency on name plate	145
6	Brake motor for specific applications HBV	146
6.1	General specifications	148
6.2	Designation	149
6.3	Specifications	149
6.4	Radial and axial loads on shaft end	153
6.5	Motor brake specifications HBV	154
6.6	Technical data 400V 50Hz	156
6.7	Technical data 230.460V 60Hz	162
6.8	Technical data 380V 60Hz	164
6.9	Motor dimensions	166
6.10	Non-standard designs and accessories	169
6.11	Name plate	174
6.12	Standard voltage/frequency on name plate	175

7	Asynchronous three-phase motor HE	176
	7.1 General specifications	178
	7.2 Designation	179
	7.3 Specifications	179
	7.4 Radial and axial loads on shaft end	182
	7.5 Technical data 400V 50Hz	184
	7.6 Motor dimensions	186
	7.7 Non-standard designs and accessories	188
	7.8 Name plate	195
8	Brake motor for gearmotors HEZ	196
	8.1 General specifications	198
	8.2 Designation	199
	8.3 Specifications	199
	8.4 Radial and axial loads on shaft end	202
	8.5 Motor brake specifications HEZ	203
	8.6 Technical data 400V 50Hz	204
	8.7 Motor dimensions	206
	8.8 Non-standard designs and accessories	208
	8.9 Name plate	216
9	Installation and maintenance	218
	9.1 General safety instructions	220
	9.2 Installation: general directions	221
	9.3 Periodical maintenance	222
	9.4 Connections	224
10	Technical formulae	228

Rossi for You



Innovation

Rossi offers a wide range of solutions for an evolving industry, flexible and innovative gearboxes and gearmotors for customer tailored solutions to maximize performance and minimize the total cost of ownership.



High quality, 3 years warranty

Our drive is to innovate and boost operations by manufacturing performing, precise, reliable and high-quality products all over the world. We are always one step forward in offering and developing solutions that can satisfy an unlimited number of application needs, even in the most demanding conditions.



Reliability

We are a reliable company with the right flexibility and know-how to respond to worldwide market requests, in all application fields, without leaving aside our commitment for the environment and value on human safety, to protect everyone's future.



Tools and processes

We continue to invest in new tools and processes, so our highly skilled specialist team in different fields are supporting you to find the best solution suitable for your demands, always by your side on every step of the project.



After-sale service

Highly trained mechanics and support teams can ensure a fast and efficient after-sale service providing support worldwide.



Digital support

Alongside our 24/7 Rossi for You support portal you have a suite of digital support tools enabling real time access to your order tracking, invoices, spare part tables download and contact to our service.

70
YEARS

Experience

Shaped by 70 years of history Rossi meets your unique needs whether you need a standard design or a customized solution.



Global presence local service



Local support

Sales, customer service, technical support, spare parts



17 branches*



Worldwide distribution network*

A global network of subsidiaries and dealers. From design and execution to after-sales service. Rossi is always close to you: a local, reliable and flexible partner.

Alongside our 24/7 **Rossi for You** portal you have a suite of digital support tools enabling real time access to your order tracking, invoices, spare part tables download and contact to our service.



*All contacts available on www.rossi.com



Main offices



Affiliated companies



Production facilities/Assembly plants

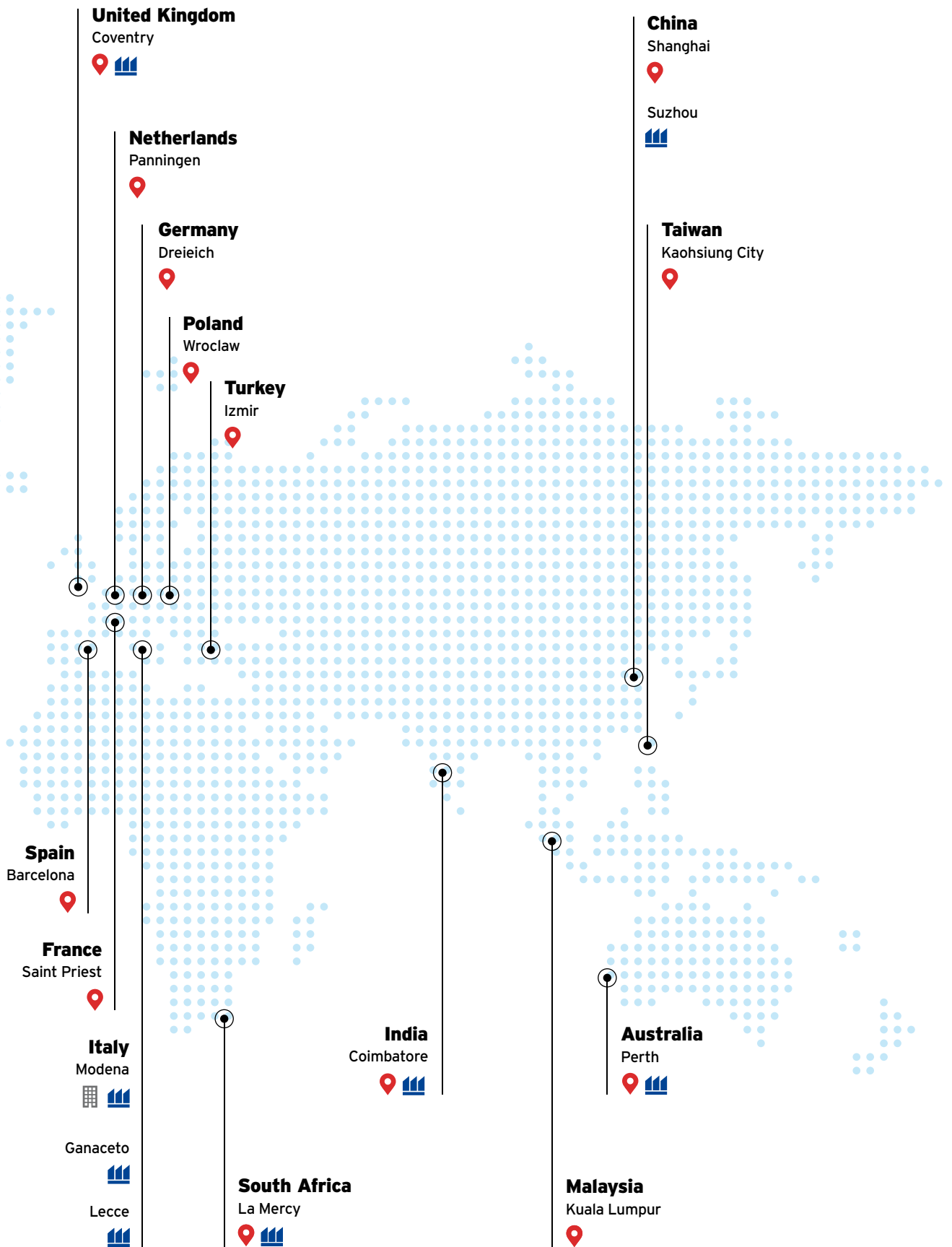

Product Overview

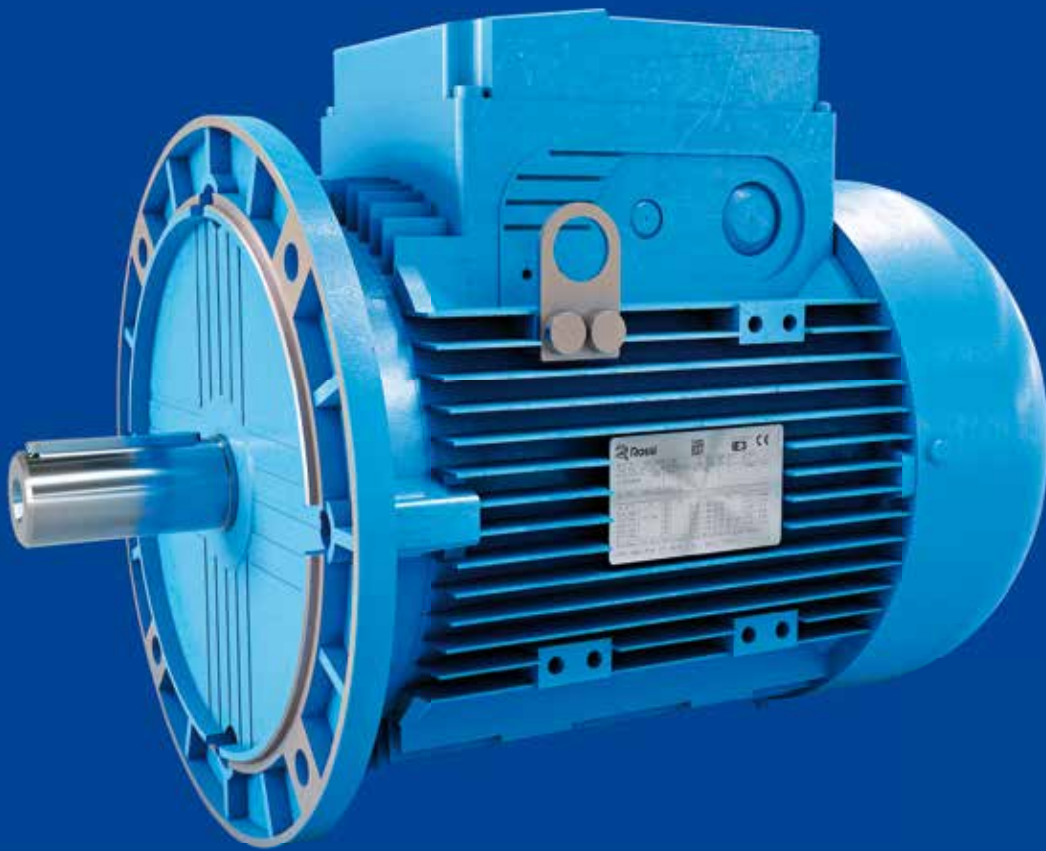

Section contents

2.1	Features, benefits and range	12
2.2	Asynchronous three-phase motors, brake motors	14
2.3	Symbols and units of measure	18
2.4	Energy efficiency classes	19
2.5	Duty types	20
2.6	Verifying and evaluating calculations	20
2.7	Variations of nominal specifications	21
2.8	Sound levels	22
2.9	Running with inverter	22
2.10	Tolerances	27
2.11	Specific standards	28
2.12	Regulations to standard 2012/19/EU	28

2.1

Features, benefits and range

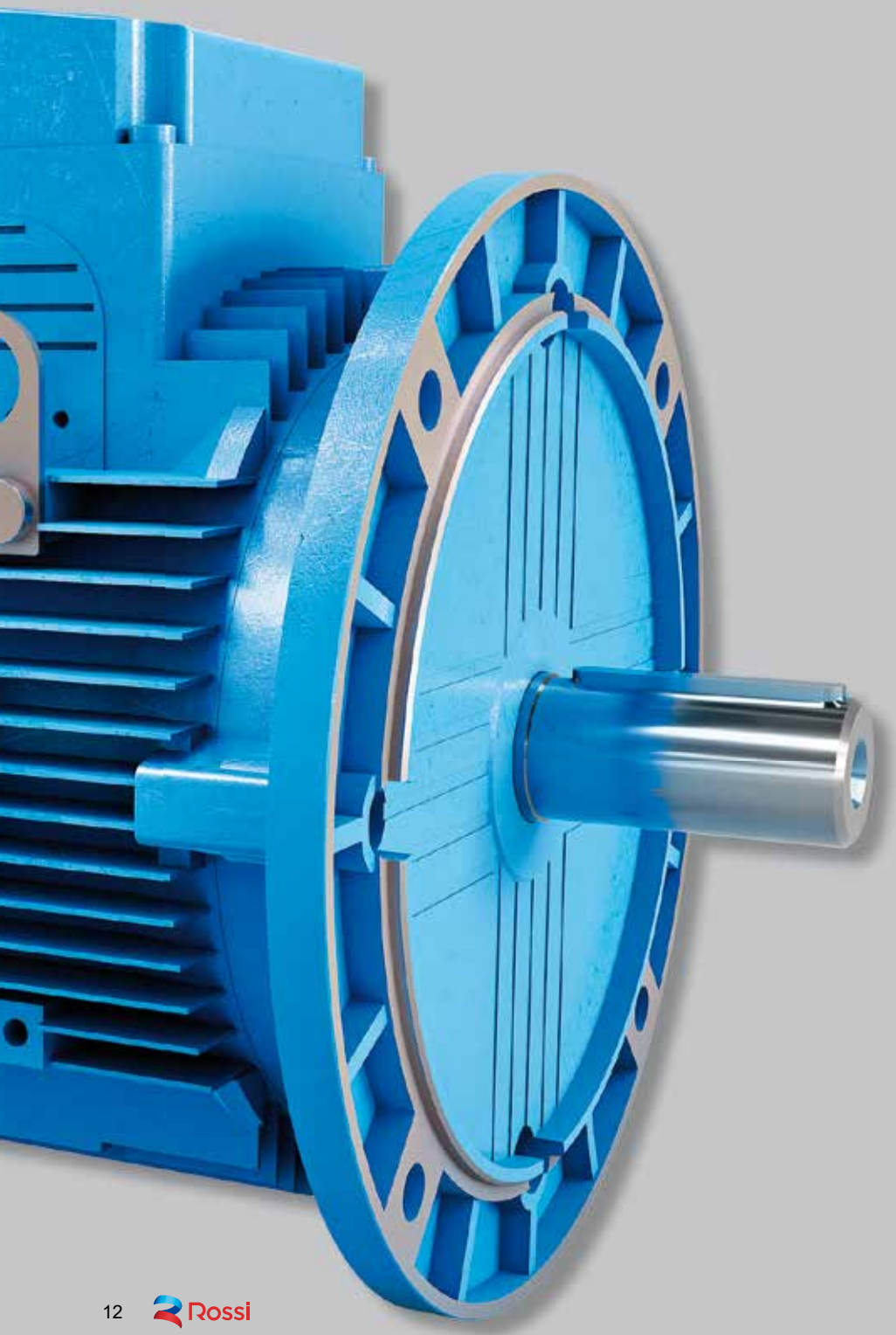



Maximum performance

We drive the heaviest applications worldwide

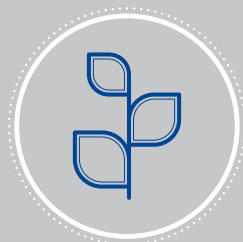

Sustainability

Compliance with the latest energy efficiency regulations



Modular system

Maximum flexibility and cost efficiency



Innovation

We are constantly thinking forward, solutions for an evolving industry



Digitalization

Rossi for You is always at your disposal for any info



Know-how

We support you through interdisciplinary know-how

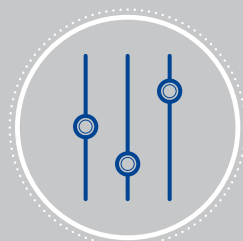

Customization

Cost-efficiency starting from standard solutions

**Asynchronous
three-phase motor**



**Brake motor
Asynchronous three-phase**



- **Advanced design offering cutting-edge solutions**
- **Competitiveness, performance, quality**
- **Enhanced efficiency**
- **Compliance with the latest standards concerning energy efficiency**
- **Maximum versatility thanks to our wide non-standard design range, the compliance to NEMA MG 1-12 as standard, and the availability of the brake motor versions**
- **Easy application in NEMA environment**
- **Five voltage values**
- **Cable glands already assembled (HE, HEZ series)**
- **Axial fastening on drive end (HE, HEZ series)**

- **Multi-voltage brake rectifier** (patent pending) generating a pre-set constant output voltage independent from input supply (and from its fluctuations) and, compared to a usual rectifier, reducing the voltage, and keeping the brake released
- **Higher steadiness of brake characteristics, lower energy consumption, lower coil heating and lower braking delay**
- **No special brake coil**
- **Ready to be used in NEMA environment**
- **Max stock availability and flexibility**



- Generous electromagnetic sizing: low loss magnetic insulated stamping, high copper volume, phase separators on head, insulation class F, overtemperature class B
- Compliance to different energy saving regulations:
- **Maximum resistance to thermal stresses typical of brake motor applications**
- **Maximum inverter duty suitability**



IE2 - IE3 - IE4 (ErP)

2.2

Asynchronous three-phase motors, brake motors



HB - HE
Asynchronous three-phase motor



HBZ - HEZ
Asynchronous three-phase **brake**
motor with **d.c. brake**



HBF
Asynchronous three-phase **brake**
motor with **a.c. brake**



HBV
Asynchronous three-phase **brake**
motor with **d.c. safety brake**

Advanced design motors sharing the **same stator windings**, the same **rotors**, the same **housings**, the same **flanges**, the same performance, and the majority of technical solutions with its twin brake motor series (**HBZ, HEZ, HBF, and HBV**).

The generous electromagnetic sizing allow to achieve **high efficiency values** complying **with different energy saving regulations**:

– Efficiency class **IE2 - IE3 - IE4 (ErP)**;

The electric design (terminal block, name plate, etc.) has been studied to comply, as standard, also with **NEMA MG1-12** for the maximum application flexibility and facility.

The strength and the precision of mechanical construction, the generous bearings and the wide range of non-standard designs available on catalog make this motor particularly suitable for coupling with gearmotors.

Thanks to its outstanding **low noise**, **progressivity** and **dynamic** characteristics, it is specifically suitable for **coupling with gearmotor minimizing the dynamic overloads** deriving from **starting and braking phases** (especially in case of motion reversals) and maintaining a **very good braking torque value**.

The excellent **operation progressivity** - when starting and braking - is assured by the brake anchor which is less quick in the impact (compared to a.c. HBF) and by the slight quickness of d.c. brakes.

Offering a comprehensive **range of accessories and non-standard designs** in order to satisfy all possible gearmotor application fields.

The **high reactivity** typical of **a.c. brake** and the **high braking capacity** make this brake motor **particularly suitable for heavy duties** requiring **quick brakings** and a **high number of operations** (e.g.: lifts with high frequency of starting, usually for size < 132, and/or for jog operations).

Vice versa, its very **high dynamic characteristics** (rapidity and frequency of starting) **are not advisable for the use in gearmotor** coupling, especially when these features are not strictly necessary for the application (avoiding useless overloads on the whole transmission).

Comprehensive **range of accessories and non-standard designs** in order to satisfy all application needs of gearmotors (in particular for HBF: IP 56, IP 65, encoder, independent cooling fan, independent cooling fan and encoder, double extension shaft, etc.).

Featuring **maximum economy**, **very reduced overall dimensions and moderate braking torque**, it is suitable for the coupling with gearmotor and can be applied as brake for **safety or parking stops** (e.g. cutting machines) and for operations at deceleration ramp end **during the running with inverter**.

The standard cast iron fan supplies a flywheel effect increasing the very good progressivity of starting and braking (typical of d.c. brake) being particularly **suitable for «light»¹⁾ traverse movements**.

1) Mechanism group M4 (max 180 starts/h) and on-load running L1 (light) or L2 (moderate) to ISO 4301/1, F.E.M./II 1997.

2.3

Symbols and units of measure

Symbols	Description	Unit of Measure SI
C	torque derating	-
C	brake disk wear (reduction of thickness)	[mm]
C_{max}	maximum brake disk wear allowed	[mm]
cosφ	power factor	-
η	efficiency = ratio between mechanic power available and electric power absorbed	-
f	frequency	[Hz]
f_{min}	minimum and maximum operating frequency	[Hz]
f_{max}	minimum and maximum operating frequency	[Hz]
I_N	nominal current	[A]
I_S	starting current	[A]
J₀	moment of inertia (of mass) of the motor	[kg m ²]
J_V	flywheel additional moment of inertia (of mass) in case of W design; value to be added to J ₀ to obtain total motor moment of inertia	[kg m ²]
J	external moment of inertia (of mass) (couplings, transmission, gear reducer, driven machine) referred to motor shaft	[kg m ²]
M_N	nominal torque	[N m]
M_S	starting torque, with direct on-line start	[N m]
M_{max}	maximum torque, with direct on-line start	[N m]
M_a	mean acceleration torque	[N m]
M_f	braking torque	[N m]
M_{required}	torque absorbed by the machine through work and frictions	[N m]
n_N	nominal speed	[min ⁻¹]
n_{min}	minimum and maximum operating speed	[min ⁻¹]
n_{max}	minimum and maximum operating speed	[min ⁻¹]
P_N	nominal power	[kW]
P_{required}	power absorbed by the machine referred to motor shaft	[kW]
R	frequency variation ratio	-
t₁	delay of anchor release	[ms]
t₂	delay of braking	[ms]
t_a	starting time	[s]
t_f	braking time	[s]
φ_a	starting rotation angle	[rad]
φ_f	braking rotation angle	[rad]
μ	friction coefficient	-
U	electric voltage	[V]
W₁	friction work generating a brake disk wear of 1 mm	[MJ/mm]
W_f	friction work dissipated for each braking	[J]
z₀	maximum number of no-load starts/h allowed by motor with cyclic duration factor 50%	[starts/h]

Energy efficiency classes

The directive 2009/125/EC for the «Ecodesign» of the Energy-related Products (directive ErP), decrees that the asynchronous three-phase electric motors addressed to the European market are in energy efficiency class **IE2/IE3** or higher, according to the 3 efficiency classes defined by **IEC 60034-30**:

IE2: high efficiency class;

IE3: premium efficiency class;

IE4: super premium efficiency class.

The applicability limits of IEC 60034-30 are:

- asynchronous three-phase motors at 50 or 60 Hz;
- one-speed: 2, 4, 6 e 8 poles;
- supply voltage max 1000 V;
- power range 0,12 ... 375 kW;
- continuous or intermittent duty S3 80% or higher.

Excluding some motor types, such as:

- motors based on a **non-continuous running duty** (e.g. duty S3 < 80%);
- motors for **ambient temperature > 60°C**;
- **Totally Enclosed Non-Ventilated** motors (TENV);
- motors **integrated** in machines which cannot be tested separately.

For further excluded categories refer to the official European regulation.

Similar regulations concerning energy saving are in force for the markets of the United States and Canada (**EISA**, Energy Independence and Security Act). Also in this case the regulation refers to motors in S1 continuous running duty.

P _N kW hp	Efficiency class definition																				
	2 poles						4 poles						6 poles								
	400V - 50Hz			460V - 60Hz			400V - 50Hz			460V - 60Hz			400V - 50Hz			460V - 60Hz					
	IE1	IE2	IE3	IE4	IE2	IE3	IE4	IE1	IE2	IE3	IE4	IE2	IE3	IE4	IE1	IE2	IE3	IE4	IE2	IE3	IE4
0,12 0,16	45,0	53,6	60,8	66,5	59,5	62,0	66,0	50,0	59,1	64,8	69,8	64,0	66,0	70,0	38,3	50,6	57,7	64,9	50,5	64,0	68,0
0,15 0,20	49,5 ¹⁾	57,6 ¹⁾	63,7 ¹⁾	68,9 ¹⁾	64,0	65,6	70,0	54,1 ¹⁾	62,3 ¹⁾	67,7 ¹⁾	72,7 ¹⁾	68,0	69,5	74,0	42,1 ¹⁾	53,8 ¹⁾	61,1 ¹⁾	67,8 ¹⁾	55,0	67,5	72,0
0,18 0,25	52,8	60,4	65,9	70,8	64,0	65,6	70,0	57,0	64,7	69,9	74,7	68,0	69,5	74,0	45,5	56,6	63,9	70,1	55,0	67,5	72,0
0,25 0,33	58,2	64,8	69,7	74,3	68,0	69,5	74,0	61,5	68,5	73,5	77,9	70,0	73,4	77,0	52,1	61,6	68,6	74,1	59,5	71,4	75,5
0,37 0,5	63,9	69,5	73,8	78,1	72,0	73,4	77,0	66,0	72,7	77,3	81,1	72,0	78,2	81,5	59,7	67,6	73,5	78,0	64,0	75,3	78,5
0,55 0,75	69,0	74,1	77,8	81,5	74,0	76,8	80,0	70,0	77,1	80,8	83,9	75,5	81,1	84,0	65,8	73,1	77,2	80,9	68,0	81,7	82,5
0,75 1	72,1	77,4	80,7	83,5	75,5	77,0	82,5	72,1	79,6	82,5	85,7	82,5	85,5	85,5	70,0	75,9	78,9	82,7	80,0	82,5	84,0
1,1 1,5	75,0	79,6	82,7	85,2	82,5	84,0	85,5	75,0	81,4	84,1	87,2	84,0	86,5	87,5	72,9	78,1	81,0	84,5	85,5	87,5	88,5
1,5 2	77,2	81,3	84,2	86,5	84,0	85,5	86,5	77,2	82,8	85,3	88,2	84,0	86,5	88,5	75,2	79,8	82,5	85,9	86,5	88,5	89,5
1,85 2,5	78,6 ¹⁾	82,3 ¹⁾	85,1 ¹⁾	87,4 ¹⁾	85,5 ¹⁾	86,5 ¹⁾	88,5	78,6 ¹⁾	83,6 ¹⁾	86,1 ¹⁾	88,9 ¹⁾	87,5 ¹⁾	89,5 ¹⁾	91,0	76,6 ¹⁾	80,9 ¹⁾	83,5 ¹⁾	86,8 ¹⁾	87,5 ¹⁾	89,5 ¹⁾	90,2
2,2 3	79,7	83,2	85,9	88,0	85,5	86,5	88,5	79,7	84,3	86,7	89,5	87,5	89,5	91,0	77,7	81,8	84,3	87,4	87,5	89,5	90,2
3 4	81,5	84,6	87,1	89,1	87,5 ¹⁾	88,5 ¹⁾	89,5	81,5	85,5	87,7	90,4	87,5 ¹⁾	89,5 ¹⁾	91,0	79,7	83,3	85,6	88,6	87,5 ¹⁾	89,5 ¹⁾	90,2
4 5,4	83,1	85,8	88,1	90,0	87,5 ¹⁾	88,5 ¹⁾	89,5	83,1	86,6	88,6	91,1	87,5 ¹⁾	89,5 ¹⁾	91,0	81,4	84,6	86,8	89,5	87,5 ¹⁾	89,5 ¹⁾	90,2
5,5 7,5	84,7	87,0	89,2	90,9	88,5	89,5	90,2	84,7	87,7	89,6	91,9	89,5	91,7	92,4	83,1	86,0	88,0	90,5	89,5	91,0	91,7
7,5 10	86,0	88,1	90,1	91,7	89,5	90,2	91,7	86,0	88,7	90,4	92,6	89,5	91,7	92,4	84,7	87,2	89,1	91,3	89,5	91,0	92,4
9,2 12,5	86,9 ¹⁾	88,8 ¹⁾	90,7 ¹⁾	92,2 ¹⁾	89,5 ¹⁾	90,2 ¹⁾	91,7	86,9 ¹⁾	89,3 ¹⁾	91 ¹⁾	93,0 ¹⁾	89,5	91,7 ¹⁾	92,4	85,6 ¹⁾	88 ¹⁾	89,7 ¹⁾	91,9 ¹⁾	89,5 ¹⁾	91 ¹⁾	92,4
11 15	87,6	89,4	91,2	92,6	90,2	91,0	92,4	87,6	89,8	91,4	93,3	91,0	92,4	93,6	86,4	88,7	90,3	92,3	90,2	91,7	93,0
15 20	88,7	90,3	91,9	93,3	90,2	91,0	92,4	88,7	90,6	92,1	93,9	91,0	93,0	94,1	87,7	89,7	91,2	92,9	90,2	91,7	93,0
18,5 25	89,3	90,9	92,4	93,7	91,0	91,7	93,0	89,3	91,2	92,6	94,2	92,4	93,6	94,5	88,6	90,4	91,7	93,4	92,4	93,0	94,1
22 30	89,9	91,3	92,7	94,0	91,0	91,7	93,0	89,9	91,6	93,0	94,5	92,4	93,6	94,5	89,2	90,9	92,2	93,7	92,4	93,0	94,1
30 40	90,7	92,0	93,3	94,5	91,7	92,4	93,6	90,7	92,3	93,6	94,9	93,0	94,1	95,0	90,2	91,7	92,9	94,2	93,0	94,1	95,0
37 50	91,2	92,5	93,7	94,8	92,4	93,0	94,1	91,2	92,7	93,9	95,2	93,0	94,5	95,4	90,8	92,2	93,3	94,5	93,0	94,1	95,0
45 60	91,7	92,9	94,0	95,0	93,0	93,6	94,5	91,7	93,1	94,2	95,4	93,6	95,0	95,4	91,4	92,7	93,7	94,8	93,6	94,5	95,4
55 75	92,1	93,2	94,3	95,3	93,0	94,1	94,5	92,1	93,5	94,6	95,7	94,1	95,4	95,8	91,9	93,1	94,1	95,1	93,6	94,5	95,4
75 100	92,7	93,8	94,7	95,6	93,6	95,0	95,0	92,7	94,0	95,0	96,0	94,5	95,4	96,2	92,6	93,7	94,6	95,4	94,1	95,0	95,8
90 125	93,0	94,1	95,0	95,8	94,5	95,0	95,4	93,0	94,2	95,2	96,1	94,5	95,4	96,2	92,9	94,0	94,9	95,6	94,1	95,8	95,8
110 150	93,3	94,3	95,2	96,0	94,5	95,0	95,4	93,3	94,5	95,4	96,3	95,0	95,8	96,2	93,3	94,3	95,1	95,8	95,0	95,8	96,2
132 180	93,5	94,6	95,4	96,2	95,0	95,4	95,8	93,5	94,7	95,6	96,4	95,0	96,2	96,5	93,5	94,6	95,4	96,0	95,0	95,8	96,2
150 200	93,7 ¹⁾	94,7 ¹⁾	95,5 ¹⁾	96,3 ¹⁾	95,0	95,4	95,8	93,7 ¹⁾	94,9 ¹⁾	95,8 ¹⁾	96,5 ¹⁾	95,0	96,2	96,5	93,7 ¹⁾	94,7 ¹⁾	95,5 ¹⁾	96,1 ¹⁾	95,0	95,8	96,2
160 215	93,8	94,8	95,6	96,3	95,0	95,4	95,8	93,8	94,9	95,8	96,6	95,0	96,2	96,5	93,8	94,8	95,6	96,2	95,0	95,8	96,2
185 250	93,9 ¹⁾	95,0 ¹⁾	95,7 ¹⁾	96,5 ¹⁾	95,4	95,8	96,2	93,9 ¹⁾	95,1 ¹⁾	95,9 ¹⁾	96,7 ¹⁾	95,0	96,2	96,5	93,9 ¹⁾	94,9 ¹⁾	95,7 ¹⁾	96,3 ¹⁾	95,0	95,8	96,2
200 270	94,0	95,0	95,8	96,5	95,4	95,8	96,2	94,0	95,1	96,0	96,7	95,0	96,2	96,5	94,0	95,0	95,8	96,3	95,0	95,8	96,2

1) Efficiency limit value obtained through interpolation.

2.5

Duty types

Rated motor powers are referred to S1 continuous running duty (except where differently stated). In case of a duty-requirement type S2 ... S10 the motor power can be increased as per the following table; starting torque keeps unchanged.

Continuous running duty (S1). - Operation at a constant load maintained for sufficient time to allow the motor to reach thermal equilibrium.

Short time duty (S2). - Running at constant load for a given period of time less than that necessary to reach normal running temperature, followed by a rest period long enough for motor's return to ambient temperature.

Intermittent periodic duty (S3). - Succession of identical work cycles consisting of a period of running at constant load and a rest period. Current peaks on starting are not to be of an order that will influence motor heat to any significant extent.

$$\text{Cyclic duration factor} = \frac{N}{N+R} \cdot 100\%$$

N being running time at constant load,

R the rest period and $N + R = 10$ min (if longer consult us).

Duty			Motor size ¹⁾		
			63 ... 90	100 ... 160S	160M ... 315
S1			1	1	1
S2	duration of running	90 min	1	1	1,06
		60 min	1	1,06	1,12
		30 min	1,12	1,18	1,25
		10 min	1,25	1,25	1,32
S3	cyclic duration factor	70%	1,12		
		60%	1,18		
		40%	1,25		
		25%	1,32		
		15%			
S4 ... S10		Consult Rossi S.p.A.			

1) For motors identified by symbol □ at ch. 3.5, 3.6, 4.6, 4.7, 5.6, 5.7, 6.6, 6.7, 7.5, 8.6 consult Rossi S.p.A..

2.6

Verifying and evaluating calculations

Main necessary verifications so that motor and brake can satisfy application needs are:

- given required torque and applied inertiae, **frequency of starting** has not to exceed maximum value permissible by motor windings without overheatings;
- given number of brakings/h, **work of friction for each braking** has not to exceed maximum permissible value of friction surface.

See below verification modalities.

Maximum frequency of starting z

As a guide, maximum frequency of starting z, for a starting time $0,5 \div 1$ s and with direct on-line start, is 125 starts/h for sizes 63 ... 90, 63 starts/h for sizes 100 ... 160S, 16 starts/h for sizes 160M ... 315; halve the values for motors with flywheel (see non-standard design 4.(23)), which, having a higher J_0 (to get progressive starts and stops), can have a lower number of starts at the same conditions.

When it is necessary to have a higher frequency of starting, verify that:

$$z \leq z_0 \cdot \frac{J_0}{J_0 + J} \cdot K \cdot \left[1 - \left(\frac{P_{\text{required}}}{P_N} \right)^2 \cdot 0,6 \right]$$

$K = 1$ if motor, during the starting, must only overcome inertial loads;

$K = 0,63$ if motor, during the starting, must also overcome resistant friction, work, lifting loads, etc.

Where results are unsatisfactory or where frequent hypersynchronous brakings occur, more detailed verification formulae can be utilised: **consult Rossi S.p.A.**

Maximum work of friction for each braking W_f

In case of a high number of brakings/h ($z > 0,2 z_0$) or very high inertiae applied ($J > 10 J_0$) it is necessary to verify that work of friction for each braking does not exceed maximum permissible value of W_{fmax} as shown at points 2.4, 4.5, 5.5 according to frequency of braking (for intermediate values of frequency apply the lowest value and interpolate, if necessary):

$$W_{fmax} \geq M_f \cdot \varphi_f \quad [J]$$

for the calculation of φ_f see below.

Starting time t_a and motor rotation angle φ_a

$$t_a = \frac{(J_0 + J) \cdot n_N}{9,55 \cdot (M_S - M_{required})} \quad [s] \qquad \varphi_a = \frac{t_a \cdot n_N}{19,1} \quad [rad]$$

For more accurate calculations replace M_S with a mean acceleration torque, usually $M_a \approx 0,85 \cdot M_S$.

Braking time t_f and motor rotation angle φ_f

$$t_f = \frac{(J_0 + J) \cdot n_N}{9,55 \cdot (M_f + M_{required})} \quad [s] \qquad \varphi_f = \frac{t_f \cdot n_N}{19,1} \quad [rad]$$

If $M_{required}$ tends to pull the motor (e.g. overhung load) introduce a negative number in the formulae.

Assuming a regular air-gap and ambient humidity and utilising suitable electrical equipment, repetition of the braking action, as affected by variation in temperature of the brake and by the state of wear of friction surface, is approx. $\pm 0,1 \cdot \varphi_f$.

Duration of friction surface

As a guide, the number of **brakings** permissible **between successive adjustments** of the air-gap is given by the formula:

$$\frac{W_1 \cdot C \cdot 10^6}{M_f \cdot \varphi_f}$$

for the calculation of **periodical air-gap adjustment**, C value is given by the difference between max and min values of the air-gap; for **total brake disk life calculation**, C value is given by the maximum wear value C_{max} (see points 2.4, 4.5, 5.5).

2.7

Variations of nominal specifications

Supply differs from nominal values

Functional specifications of a three-phase motor **supplied at voltage and/or frequency differing** from the nominal ones can be obtained approximately by multiplying nominal data of technical data by correction factors stated in the table valid for the motor only.

Nominal supply	Alternative supply ²⁾		Multiplicative factors of catalog value					
	Frequency [Hz]	Voltage [V]	P_N	n_N	I_N	M_N	I_S	M_S, M_{max}
Δ230 Y400 V 50 Hz	50	Δ220 Y380	1	1	0,95 ÷ 1,05	1	0,96	0,9
		Δ240 Y415	1	1	0,95 ÷ 1,05	1	1,04	1,08
	60	Δ220 Y380 ¹⁾	1	1,19	0,95 ÷ 1,05	0,83	0,79	0,63
		Δ255 Y440 ¹⁾²⁾	1,1	1,2	0,95 ÷ 1	0,92	0,92	0,84
Δ400 V 50 Hz	50	Δ265 Y460 ²⁾	1,15 ÷ 1,1 ³⁾	1,2	0,95 ÷ 1,05	0,96 ÷ 0,92 ³⁾	0,96	0,92
		Δ277 Y480 ²⁾	1,2 ÷ 1,15 ⁴⁾	1,2	1	1 ÷ 0,96 ⁴⁾	1	1
	60	Δ380	1	1	0,95 ÷ 1,05	1	0,96	0,9
		Δ415	1	1	0,95 ÷ 1,05	1	1,04	1,08
Δ400 V 50 Hz	60	Δ380 ¹⁾	1	1,19	0,95 ÷ 1,05	0,83	0,79	0,63
		Δ440 ¹⁾²⁾	1,1	1,2	0,95 ÷ 1	0,92	0,92	0,84
	Δ460 ²⁾	1,15 ÷ 1,1 ³⁾	1,2	0,95 ÷ 1,05	0,96 ÷ 0,92 ³⁾	0,96	0,92	
	Δ480 ²⁾	1,2 ÷ 1,15 ⁴⁾	1,2	1	1 ÷ 0,96 ⁴⁾	1	1	

1) Up to size 132MB, standard motor can also operate with this supply provided that higher temperature rise values are acceptable without on-load starts and that the power requirement is not unduly demanding (P_N in the table); this supply is not shown on motor name plate.

2) For brake voltage value, see ch. 4.9 (1), 5.9 (1), 6.9 (1).

3) Value valid for size $\geq 160M$.

4) Value valid for sizes 160L 4, 180M 4, 200L 4 and 250M 4.

2.8

Sound levels

The sound power emission level L_{WA} relevant to the motor of this catalog comply with the limits settled by EN 60034-9.

2.9

Running with inverter

Rossi motors are suitable for running with PWM inverter (limit values : chopper frequency $4 \div 16$ kHz, $dU/dt < 1$ kV/ μ s, $U_{max} < 1000$ V, $U_N < 500$ V, wire length ≤ 30 m; for greater values see «Voltage peaks (U_{max}), voltage gradients (dU/dt), cable length») since they are specifically conceived and featured by construction solutions which also allow this kind of application. The most important specifications are: **generous electromagnetic sizing**; use of low-loss **electrical stamping** (higher torque both at high and low frequency, good overload withstanding); **phase separators**; **insulation system** with high thermal and dielectric margins and great resistance to mechanical stresses and vibrations; rotor **careful dynamical balancing**; **bearings with lubrication grease for high temperatures**; **wide range of specific designs for running with inverter** (independent cooling fan, additional windings impregnation, bi-metal or thermistor type thermal probes, encoder, etc.).

Torque M available on motor

The inverter supplies the motor at variable voltage U and frequency f by keeping constant the U/f ratio (which can be calculated with the values on name plate). For $U \leq U_{mains}$, with constant U/f , motor changes its speed in proportion to frequency f and, if loaded with nominal torque M_N , absorbs a current $I \approx I_N$.

When f increases, since the inverter cannot produce an output voltage higher than the input one, when U reaches the mains value the U/f ratio decreases (motor runs under-voltage supplied) and at the same time, with the same absorbed current, M proportionately decreases.

Asynchronous three-phase motor supplied by inverter provides, at low frequency for thermal reasons, at high frequency for electrical reasons (U/f lower than name plate data) a torque **M lower than the nominal one M_N** , according to running **frequency** and to **cooling** (self-cooled or independently cooled motor).

For running at $2,5 \leq f \leq 5$ Hz it is necessary to have a **vector inverter** (to avoid any irregular running and anomalous absorption). For motor wound for **$\Delta 230$ V 50 Hz** and three-phase supply inverter **400 V 50 Hz** it is possible to have two running types.

A) Running with $U/f \approx$ constant up to 50 Hz (Y-connected motor; it is the most common one):

$$P_{an\ max} \approx P_N, \quad I = I_{N\ 400\ V}$$

For supply frequency:

- **5¹⁾ ÷ 25 Hz**, since self-cooled motor is slightly cooled, M is decreased by decreasing speed (M keeps constant for independently cooled motor or for intermittent duty; see short dashed line);
- **25 ÷ 50 Hz**, motor runs at constant $M (\approx M_N)$;
- **> 50 Hz**, motor runs at constant $P (\approx P_N)$ with progressively decreased U/f ratio (frequency increases while voltage keeps unchanged) and following proportional decrease of M at the same current absorbed.

Motors wound for $\Delta 400$ V 50 Hz (standard for sizes ≥ 160 M) can only have this running type and must be Δ -connected.

B) Running with $U/f \approx$ constant up to 87 Hz (Δ -connected motor); it allows to increase the motor power, to run at higher frequency with the same frequency variation ratio or to increase the frequency variation ratio at the same derating coefficient C , etc.):

$$P_{an\ max} \approx 1,73 P_N, \quad I \approx 1,73 I_{N\ 400\ V} \approx I_{N\ 230\ V}$$

For supply frequency:

- **5¹⁾ ÷ 25 Hz**, since self-cooled motor is slightly cooled, M is decreased by decreasing speed (M keeps constant for independently cooled motor or for intermittent duty; see short dashed line);
- **25 ÷ 87 Hz**, motor runs at constant $M (\approx M_N)$;
- **> 87 Hz**, motor runs at constant $P (\approx 1,73 P_N)$ with progressively decreased U/f ratio (frequency increases while voltage keeps unchanged) and following proportional decrease of M at the same current absorbed.

The derating **coefficient $C = M/M_N$** to be applied to nominal torque in order to achieve the torque provided by motor is given by the following diagram (see also note 5).

The max torque depends on the inverter features and on the max **limitation current setting**. Usually, the values deducible from the diagram are not exceeded. With vector inverter, the torque reduction is slighter at low frequencies (e.g.: $M_{max}/M_N \approx 1,5 \div 1,3$ for $f = 5 \div 2,5$ Hz).

1) In case of motor supply using vector inverter, for continuous duty torque M keeps constant down to about 2,5 Hz.

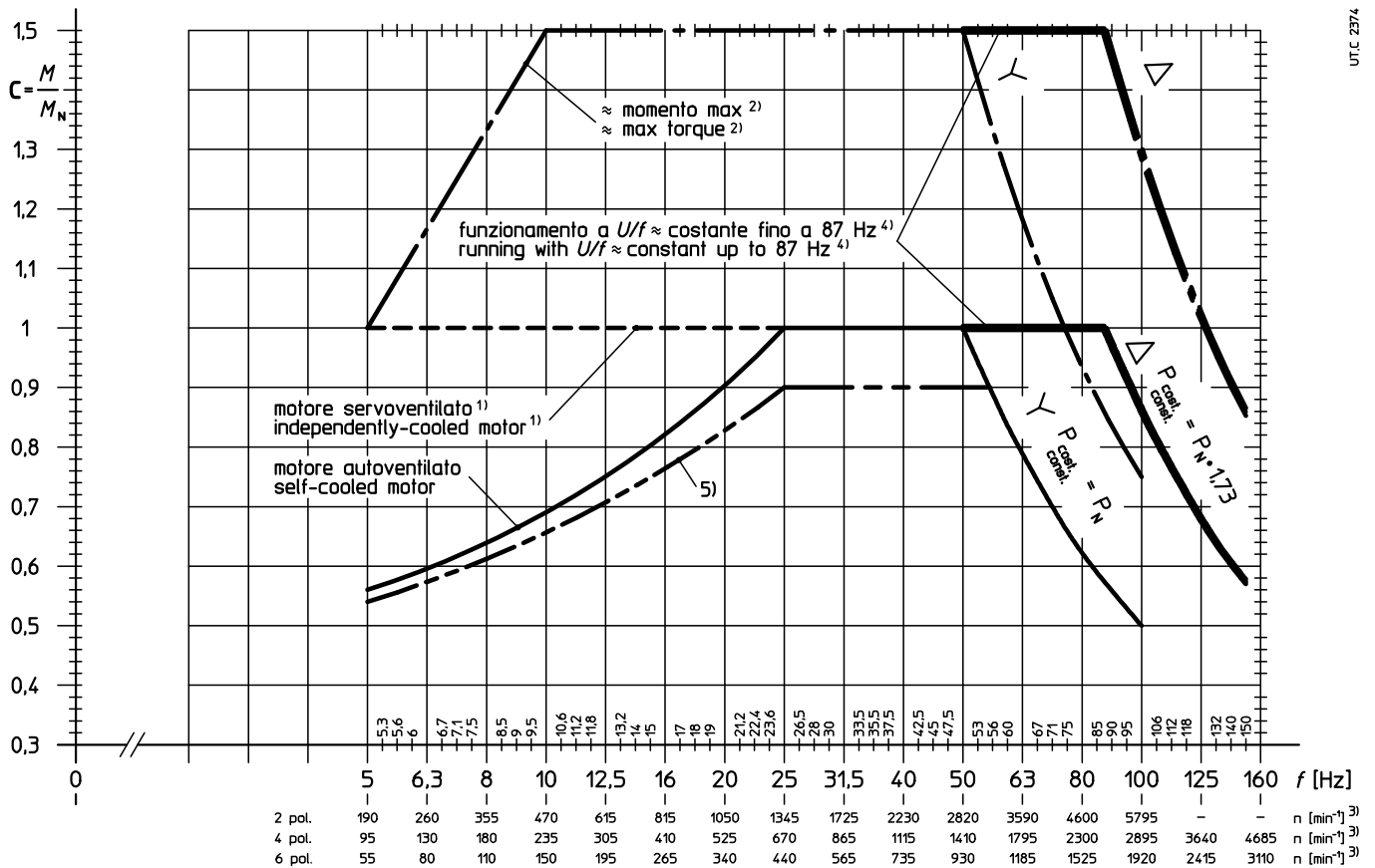

- 1) Curve valid for independently cooled motor or for intermittent duty.
- 2) Curve valid for max M for short times (accelerations, decelerations, short time overloads).
- 3) Approximate real speed refers both to slipping at nominal torque and to voltage «boost» at low frequency (with vector control, slip can be slightly lower).
- 4) Δ-connection and running with $U/f \approx \text{constant}$ up to 87 Hz.
- 5) **IMPORTANT:** curve valid for motor size $\geq 160M$, motors signed in the selection tables by symbol \square or in case of inverter with low quality wave shape.

Motor selection

Polarity. **2-poles** motor is advisable when high speeds are requested since it is less suitable to transmit the torque in a regular way at low supply frequency, but it allows to achieve higher powers at the same size; on the contrary **6-poles** motor is advisable when very low continuous speeds are requested. **Usually, 4-poles motor represents the best compromise.**

Cooling.

For running at frequency < 25 Hz it is necessary to evaluate the opportunity (both from a thermal and economical point of view) to apply an axial independent cooling fan (according to load entity and duration and to ambient temperature) in order to avoid any excessive oversizing of motor-inverter.





Frequency range.

At the same frequency variation ratio $R^{(1)} = f_{max} / f_{min}$ at constant torque, max and min running frequencies must be selected in order to minimize the derating coefficient **C** (max possible **C**).

The min and max running frequencies f_{min} and f_{max} and the **derating C** are stated in the following table, according to frequency variation ratio **R** required at constant M , to **running (A, B)** and **motor cooling type**.

1) It is necessary to consider only the frequency (i.e. speed) values relevant to the application and not the (usually low) ones characteristic of transients.

Motor wound for $\Delta 230$ Y400 V 50 Hz and three-phase supply 400 V 50 Hz.

Operation type	Motor cooling	Nominal frequency variation ratio $R^{(1)}$													
		≤ 2	2,6	3,3	4,5	6	7,1	8,3	11,3	13,5	18	20	25	30	
A) Y400 V/50 Hz $P_{a/at n max} = P_N$ $I = I_{N 400 V}$	 Self-cooled	f_{max}	50	54,5	60	63	67	71	75	80	85	90	—	—	—
		f_{min}	25	21,2	18	14	11,2	10	9	7,1	6,3	5	—	—	—
		$C^{(4)}$	1	0,91	0,85	0,79	0,74	0,7	0,66	0,62	0,59	0,56	—	—	—
		$n_{max 2}^{(2)3)}$	2 820	3 105	3 440	3 630	3 880	4 125	4 370	4 675	4 980	5 285	—	—	—
		$n_{min 2}^{(2)3)}$	1 345	1 120	930	715	540	470	410	310	260	190	—	—	—
		$n_{max 4}^{(2)}$	1 410	1 550	1 720	1 815	1 940	2 060	2 185	2 340	2 490	2 645	—	—	—
		$n_{min 4}^{(2)}$	670	560	470	360	270	235	210	155	130	95	—	—	—
		$n_{max 6}^{(2)}$	930	1 025	1 140	1 200	1 285	1 365	1 450	1 550	1 655	1 755	—	—	—
		$n_{min 6}^{(2)}$	440	365	305	230	170	150	130	95	80	55	—	—	—
		 Independently cooled	f_{max}	—	—	—	—	—	—	—	50	63	80	100	—
f_{min}	—		—	—	—	—	—	—	5	5	5	5	—		
$C^{(4)}$	—		—	—	—	—	—	—	1	0,79	0,62	0,5	—		
For $R < 10$ choose $f_{max} \leq 50$ and $f_{min} \geq 5$ according to speed and torque application requirements (always $C = 1$); consult us.										2 820	3 630	4 675	5 895	—	
$n_{min 2}^{(2)3)}$	190		210	230	245	—	—	—	—	—	—	—	—		
$n_{max 4}^{(2)}$	1 410		1 815	2 340	2 950	—	—	—	—	—	—	—	—		
$n_{min 4}^{(2)}$	95		105	115	120	—	—	—	—	—	—	—	—		
$n_{max 6}^{(2)}$	930		1 200	1 550	1 960	—	—	—	—	—	—	—	—		
$n_{min 6}^{(2)}$	55		65	75	80	—	—	—	—	—	—	—	—		
B) $\Delta 400$ V/87 Hz $P_{a/at n max} = 1,73 P_N$ $I = 1,73 I_{N 400 V}$	 Self-cooled		f_{max}	—	87	90	95	100	106	112	118	125	140	150	—
		f_{min}	—	25	21,2	18	14	11,2	10	9	7,1	6,3	5	—	
		$C^{(4)}$	—	1	0,91	0,85	0,79	0,74	0,7	0,66	0,62	0,59	0,56	—	
		$n_{max 2}^{(2)3)}$	5 020	5 215	5 525	5 835	—	—	—	—	—	—	—	—	
		$n_{min 2}^{(2)3)}$	1 345	1 120	930	715	—	—	—	—	—	—	—	—	
		$n_{max 4}^{(2)}$	2 510	2 610	2 765	2 920	3 105	3 285	3 470	3 685	4 135	4 435	—	—	
		$n_{min 4}^{(2)}$	670	560	470	360	270	235	210	155	130	95	—	—	
		$n_{max 6}^{(2)}$	1 660	1 730	1 835	1 935	2 060	2 180	2 305	2 450	2 750	2 950	—	—	
		$n_{min 6}^{(2)}$	440	365	305	230	170	150	130	95	80	55	—	—	
		 Independently cooled	f_{max}	—	—	—	—	—	—	—	—	—	87	100	125
f_{min}	—		—	—	—	—	—	—	—	—	5	5	5		
$C^{(4)}$	—		—	—	—	—	—	—	—	—	1	0,79	0,62		
For $R < 16$ choose $f_{max} \leq 87$ and $f_{min} \geq 5$ according to speed and torque application requirements (always $C = 1$); consult us.										5 020	5 835	—			
$n_{min 2}^{(2)3)}$	190		210	—	—	—	—	—	—	—	—	—	—		
$n_{max 4}^{(2)}$	2 510		2 920	3 685	4 435	—	—	—	—	—	—	—	—		
$n_{min 4}^{(2)}$	95		105	115	115	—	—	—	—	—	—	—	—		
$n_{max 6}^{(2)}$	1 660		1 935	2 450	2 950	—	—	—	—	—	—	—	—		
$n_{min 6}^{(2)}$	55		65	75	75	—	—	—	—	—	—	—	—		

- 1) Nominal frequency variation ratio $R = f_{max} / f_{min}$ is always lower than real variation ratio (n_{max} / n_{min}).
- 2) Approx. real speed refers both to **slipping** at nominal torque and to voltage boost at low frequency (2 = 2 poles motor; 4 = 4 poles motor; 6 = 6 poles motor).
- 3) Values valid for sizes $\leq 160S$.
- 4) **Important:** for motor sizes $\geq 160M$ or signed in the manufacturing programme by symbol \square or in case of inverter with low quality wave shape, consider **more prudential C** values, e.g. $0,9 \cdot C$.

Not advisable for economic reasons.
 Usually not advisable both for technical and economic reasons.

Motor power.

Proceed as follows:

- make available all necessary data of driven machine: max and min running speed¹⁾, n_{\max} and n_{\min} respectively; constant torque M_{required} ²⁾ requested in the speed variation range considered;
- determine f_{\max} , f_{\min} and **C** coefficient according to motor cooling, to running type (A, B) and to a frequency variation ratio

$$R \geq \frac{n_{\max}}{n_{\min}};$$

- choose motor polarity and then calculate transmission ratio according to

$$i = \frac{n_{\max 2, 4, 6}}{n_{\max \text{ running speed}}}$$

where $n_{\max 2, 4, 6}$ is the motor speed at max frequency f_{\max} (see table);

- choose a motor power

$$P_N \geq \frac{M_{\text{required}} \cdot n_N}{9550 \cdot C \cdot \eta \cdot i}$$

where n_N is the motor nominal speed (2 poles: 2800 min⁻¹; 4 poles: 1400 min⁻¹; 6 poles: 900 min⁻¹), η is the total **efficiency** of the transmission between motor and driven machine and **C** is the derating coefficient which is given by previous table.

Important: for motor sizes ≥ 160 or signed in the selection tables by symbol \square or in case of inverter with low quality wave shape, consider **more prudential C** values, e.g. **0,9 · C**.

- 1) It is necessary to consider only the frequency (i.e. speed) values relevant to the application and not the (usually low) ones characteristic of transients.
- 2) If not constant, consider its maximum value (in the frequency variation range relevant to a continuous duty); for very wide variations directly refer to diagram and/or consult us.

Inverter selection and programming

Requisites for the inverter: good concept and quality, adequate nominal current, correct setting of U/f characteristic curve according to motor nominal voltage, not excessive voltage «boost» (about 25% ÷ 0% for 5 ÷ 30 Hz), proper **current limitation** according to motor current (stated on the name plate) and to the admissible/required overloads; **good setting** of the innumerable drive parameters that the new generation inverters allow to program in order to avoid any problems and to optimize the drive operation.

Grandezza inverter.

It is recommended to choose an inverter with **nominal current** at least equal to **1,12 ÷ 1,25 I_N of motor and with current overload capacity** higher than 1,12 ÷ 1,25 times the torque overload required. Usually, for $M_{\max} / M_N = 1,5$, it is necessary to have $I_{\max} / I_{N \text{ motor}} \approx 1,7 \div 2$.

Considerations, indications, verifications

Acceleration time.

Check that the acceleration time programmed in the inverter is not less than the value that can be obtained with starting torque equal to 1,32 ÷ 1,5 M_N (also according to inverter current limitation); the setting of lower values causes a lower acceleration and an increase of current absorbed.

Frequency of starting.

Because of the smaller amount of current absorbed by the motor during starting (compared to direct supply), for a maximum starting time of 0,5 ÷ 1 s the max frequency of starting z is at least 180 start/h up to size 90, 90 start/h for sizes 100 ... 132, 45 start/h for larger sizes.

It is not necessary to verify frequency of starting for sufficiently long acceleration times, when accelerating torque does not exceed M_N .

Consult us for higher requirements.

Overloads.

In the case of duty featuring frequent and long lasting overloads and/or startings check the thermal suitability of inverter and motor according to the average quadratic current absorbed which should be compared to a limit value proportional to the motor nominal current I_N (the constant of proportionality depends on motor duty and cooling: consult us).

In normal conditions it is not necessary to make any kind of verification if overloads are present for less than 10 minutes per hour.

Star connection of motor (Y).

Whenever possible, due to the absence of internal circulation currents, the star connection of motor is to be preferred to the delta one, since the overtemperatures are lower (≈ -10 °C).

Chopper frequency.

High values (e.g.: 8 ÷ 16 kHz) cause a higher heating both for motor ($\approx +10$ °C) and for inverter but allow a completely noise-free running (pure tones); at the same time there is a worsening of the problems related to the electromagnetic noises, especially in case of long distances between inverter and motor ($> 5 \div 10$ m).

Brake motor and/or with independent cooling fan.

Brake and independent cooling fan must always be directly supplied from mains. When braking it is necessary to give the all-off controller to the inverter.

Motor coupled with gear reducer.

Prefer the low speed in the choice both of polarity and of position of variation range in order to limit noise level and heating and to increase the life of oil seal rings.

Inverter supply with voltage > 400 V 50/60 Hz.

After having verified the suitability of inverter to the supply voltage value, it is possible and convenient to use the motor with standard winding $\Delta 230$ Y400 V 50 Hz or $\Delta 400$ V 50 Hz (equivalent to $\Delta 277$ Y480 V 60 Hz or $\Delta 480$ V 60 Hz) by setting the inverter so that it provides to the motor a constant $U/f = U_{\text{name plate}} / f_{\text{name plate}}$. For additional precautions see following point.

Voltage peaks (U_{max}), voltage gradients (dU/dt), cable length

The use of inverters requires some precautions relevant to voltage peaks (U_{max}) and voltage gradients (dU/dt) generated by this power supply type; the values become higher by increasing the mains voltage U_N , the motor size, the power supply cable length between inverter and motor and by worsening the inverter quality.

For mains voltages $U_N > 400$ V, voltage peaks $U_{\text{max}} > 1000$ V, voltage gradients $dU/dt > 1$ kV/ μ s, supply cables between inverter and motor > 30 m, it is recommended to use non-standard motor design (see table) and/or adequate filters between inverter and motor.

Hoisting. In these cases it is advised to adopt inverter with U/f control mode since vector control could cause instability and oscillations. Consult Rossi S.p.A.

Multiple drives.

When several motors are connected simultaneously to the same inverter, this one has to be with U/f control mode.

Verifications relevant to: **deceleration time**, **braking** with regenerating running (with or without external braking resistance), braking with d.c. injection, are always to be done according to technical specifications and to programming of inverter applied.

Motor size	Non-standard designs ¹⁾ for supply from inverter		
	U_N		
	≤ 400 V	401 ÷ 499V	500 ÷ 690V
63 ... 160S	(9) ²⁾	(9) ³⁾	(9) ⁴⁾ + filter ⁵⁾
160M ... 250	(9) ²⁾	(51) ³⁾	(51) ⁴⁾ + filter ⁵⁾
280 ... 315S	(51) ²⁾	(51) ³⁾	(51) ⁴⁾ + filter ⁵⁾

1) See ch. 3.9, 4.9, 5.9, 6.9, 7.7, 8.8..

2) Design advisable by worsening the supply conditions.

3) Design necessary in presence of critical supply conditions.

4) Necessary design.

5) On customer's care.

Tolerances

Tolerances of electrical and operating specifications of the motors to standards IEC 60034-1, (CEI EN 60034-1, DIN VDE 0530-1, NF C51-111, BS 4999-101) CENELEC EN 60034-2.

Specification	Tolerance ¹⁾	
Efficiency	η	-0,15 (1- η)
Power factor	$\cos\varphi$	- (1-cos φ)/6 min 0,02, max 0,07
Sliding		$\pm 20\%$ ($\pm 30\%$ per $P_N < 1$ kW)
Locked rotor current	I_s	+ 20%
Locked rotor torque	M_s	- 15% + 25% ²⁾
Max torque	M_{max}	- 10% ³⁾
Moment of inertia	J_0	$\pm 10\%$

1) If a tolerance is specified for one direction only, the value has no limit in the other direction.

2) The value + 25% can be exceeded upon previous agreement.

3) Only if, by applying this tolerance, the torque remains equal to 1,6 times M_N , according to CEI EN 60034-2.

Mating tolerances under «accuracy» rating to IEC 60072-1 (UNEL 13501-69 DIN 42955).

Tolerance on voltage and frequency

Tolerance applicable on voltage and frequency is defined by standard IEC 60034-1 in the zones A and B as per sketch below:

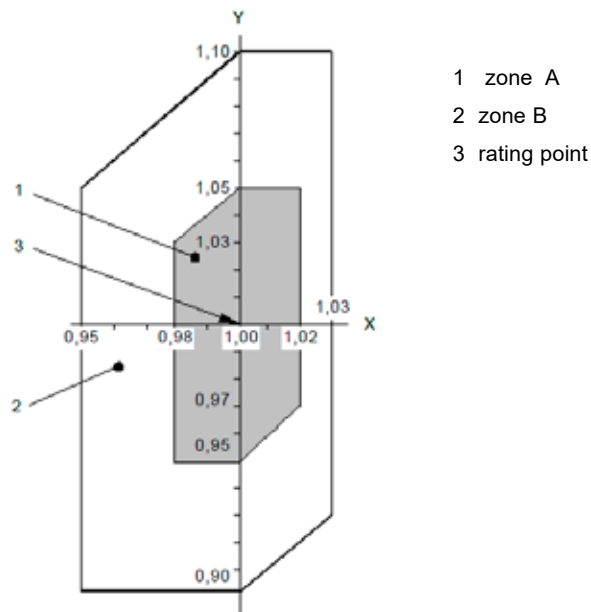

Note:

axis X: frequency (p.u.)

Axis Y voltage (p.u.)

rating point: running rating point¹⁾

In zone A (combination of variations: voltage $\pm 5\%$ and frequency $\pm 2\%$) motor supplies the nominal torque in continuous running duty (S1). Other specific values and heating can slightly differ from the ones of running rating point.

In zone B (combination of variations: voltage $\pm 10\%$ and frequency + 3% / - 5%) motor supplies the nominal torque but not in continuous running duty. Motor may show differences and temperature increase compared with zone A. The frequent motor running on zone B is to be avoided.

1) As running rating point consider voltage/frequency values stated on motor name plate.

2.11

Specific standards

Motors comply with following standards (except for any different description of each specification).

Nominal powers and dimensions:

- for mounting position IM B3 and derivatives (CENELEC HD 231, IEC 60072-1, CNR-CEI UNEL 13113-71, DIN 42673, NF C51-110, BS 5000-10 and BS 4999-141);
- for mounting position IM B5, IM B14 and derivatives IEC 60072-1, (CENELEC HD 231, CNR-CEI UNEL 13117-71 and 13118-71, DIN 42677, NF C51-120, BS 5000-10 and BS 4999-141).

Nominal performances and running specifications:

CEI EN 60034-1, EN 60034-1, IEC 60034-2.

Protection of the housings:

CEI EN 60034-5, EN 60034-5, IEC 60034-5.

Mounting positions:

CEI EN 60034-7, EN 60034-7, IEC 60034-7.

Cylindrical shaft ends:

- ISO 775-88 (UNI-ISO 775-88, DIN 748, NF E22.051, BS 4506-70) excepted the diameters up to 28 mm which are in tolerance j6;
- tapped butt-end hole to UNI 9321, DIN 332BI.2-70, NF E22.056;
- keyway to CNR-CEI UNEL 13502-72.

Terminal markings and direction of rotation:

CEI 2-8, CENELEC HD 52.8, IEC 60034-8.

Sound levels:

CEI EN 60034-9, EN 60034-9, IEC 60034-9.

Mechanical vibrations:

CEI EN 60034-14, EN 60034-14, IEC 60034-14.

Cooling systems:

CEI EN 60034-6, EN 60034-6, IEC 60034-6.

Mating tolerances:

IEC 60072-1, (CNR-CEI UNEL 13501-69 DIN 42955).

Determining of efficiency:

CEI EN 60034-2-1, EN 60034-2-1, IEC 60034-2-2.

2.12

Regulations to standard 2012/19/EU



This symbol means that the product contains materials that can be recovered or recycled and should not be disposed of with general waste.

Disposal should be in accordance with EU Directives where applicable.

Outside the European Union contact your local authorities for information on current regulations.

This page is intentionally left blank.

Asynchronous three-phase motor HB

Section contents

3.1	General specifications	32
3.2	Designation	32
3.3	Specifications	33
3.4	Radial and axial loads on shaft end	36
3.5	Technical data 400V 50 Hz	38
3.6	Technical data 230.460V 60 Hz	44
3.7	Technical data 380V 60 Hz	48
3.8	Technical data 400V 50 Hz	50
3.9	Motor dimensions	54
3.10	Non-standard designs and accessories	57
3.11	Name plate	68
3.12	Standard supply voltage	69

3.1

General specifications

63 ... 160S

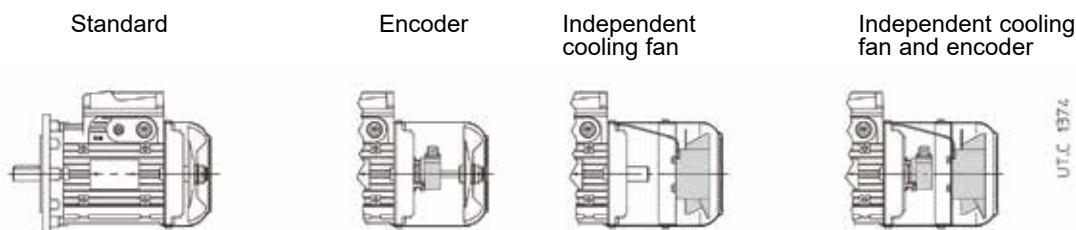

- Three-phase asynchronous motors, sizes 63 ... 132 available also with **higher powers** (marked by *) **than the ones foreseen by the standards**
- Class F insulation, temperature rise class B for all motors at standard power, B or F for remaining motors
- Mounting positions **IM B5** and derivatives, **IM B14** and derivatives and **IM B3** (sizes 63 ... 132 always pre-arranged) and corresponding vertical mounting positions; **mating tolerances under «accuracy» rating**
- **IP 55** protection
- **Particularly strong construction** (both electrical and mechanical); duly proportioned bearings
- **«Supported» tightening attachments** of endshields and flanges fitted on housing with «tight» coupling
- «Generous» electromagnetic sizing having margins of safety, good acceleration capacity (high frequency of starting) and uniform starting (slightly «sagged» characteristic curves)
- **Metallic** terminal box
- **Suitable for operation with inverter**
- **Designs available for every application need** (independent cooling fan, independent cooling fan and encoder, protections higher than IP 55, etc.).

For standard voltages as per name plate see ch. 3.11

3.2

Designation

MOTOR	HB	asynchronous three phase
EFFICIENCY CLASS	-	$P_N \geq 0,75$ kW motor extra CE 2, 4, 6 Poles ($0,75$ kW $\leq P_N \leq 15$ kW)
	2	- IE2 (ErP)
	3	- IE3 (ErP) - Premium Efficiency (EISA)
SIZE	63A ... 160S	
NUMBER OF POLES	2, 4, 6	
SUPPLY¹⁾	230.400-50 230.460-60 ²⁾	Δ 230 Y400 V 50 Hz YY230 Y460 V 60 Hz
MOUNTING POSITION	B5, B14, B3, B5R, B5A, ... B14R	IM B5, IM B14 (63 ... 132), IM B3, non-standard IM B5 non-standard IM B14
Non-standard design	,... ,... ,...	code, see ch. 3.9

HB 3 112M 4 230.400-50 B3 ,P2
HB 90LB 2 230.400-50 B14 ,AX
HB 2 71B 4 230.400-50 B5R

1) If frequency and voltage differ from those stated above, see ch. 3.9. (1).

2) Motor supply for USA and Canada (EISA): includes also terminal block with 9 terminals and UL compliance (see ch. 3.9 (42));

Specifications

Standardized asynchronous three-phase electric motor with cage rotor, totally enclosed, externally ventilated (cooling system IC 411), single-speed according to following tables:

Number of poles	Winding	Motor size	Standard supply		insulation	Class temperature rise
			50 Hz	60 Hz		
2, 4, 6	three-phase Δ Y	63 ... 160S	50 Hz	see ch. 3.11	F	B ¹⁾
	three-phase YY Y		60 Hz	YY 230 Y460 V		

1) Excluding some motors with higher power than the ones standardized (identified by □ at ch. 3.5 ... 3.7) whose temperature rise class is F.

Rated power delivered on continuous duty (S1) (except cases highlighted at ch. 3.5... 3.7 for which powers are relevant to the intermittent duty S3 70%) and at standard voltage and frequency; ambient temperature -15 ÷ 40 °C, altitude 1 000m.

IP 55 protection obtained with seal rings on drive end (without spring for IM B3) and on non-drive end (without spring).

Mounting positions IM B5, IM B14, IM B3; motors can also operate in the relevant mounting positions with vertical shaft, which are respectively (see following table): IM V1 and IM V3, IM V18 and IM V19, IM V5 and IM V6; the name plate shows the designation of mounting position with horizontal shaft. On request, other special mounting positions: consult Rossi Spa.

Mounting positions with flange

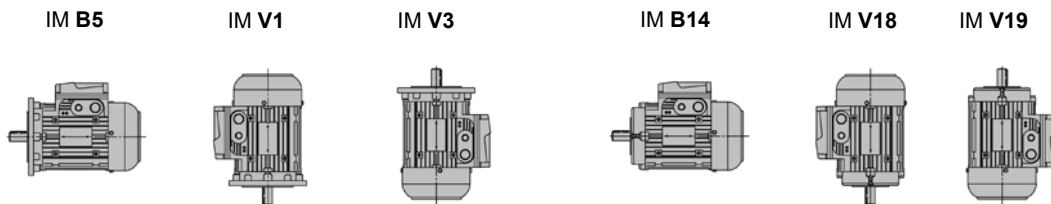

Mounting positions with feet

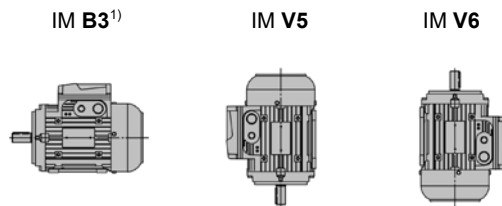

1) Motor can also operate in the mounting positions IM B6, IM B7 and IM B8; the name plate shows the IM B3 mounting position.

Main mating dimensions of the mounting positions with flange

Mounting position	Shaft end - Ø D x E Flange - Ø P							
	Motor size							
	IM	63	71	80	90	100	112	132
B3	11 × 23	14 × 30	19 × 40	24 × 50	28 × 60	28 × 60	38 × 80	42 × 110
B5	11 × 23 140	14 × 30 160	19 × 40 200	24 × 50 200	28 × 60 250	28 × 60 250	38 × 80 300	42 × 110 350
B5R	9 × 20 120	11 × 23 140	14 × 30 160	19 × 40 200	24 × 50 200	24 × 50 200	28 × 60 250	-
B5S	-	-	-	14 × 30 160 ¹⁾	19 × 40 200	19 × 40 200 ¹⁾	24 × 50 200 ¹⁾	-
B5A	11 × 23 120	14 × 30 140	19 × 40 160	-	28 × 60 200	28 × 60 200	38 × 80 250	-
B5B	-	11 × 23 120	14 × 30 140	19 × 40 160	-	-	28 × 60 200	-
B5C	-	-	-	-	19 × 40 160	-	-	-
B14	11 × 23 90	14 × 30 105	19 × 40 120	24 × 50 140	28 × 60 160	28 × 60 160	38 × 80 200	-
B14R	-	11 × 23 90	14 × 30 105	-	-	-	-	-

1) For $P_{N \max}$ max available see tab below.

Motor size	Poles					
	2		4		6	
	$P_{N \max}$ kW [hp]					
90	1,85	[2.4]	1,1	[1.5]	0,75	[1]
112	4	[5.4]	3	[4]	1,85	[2.4]
132	9,2	[12.4]	7,5	[10]	4	[5.4]

Housing in pressure diecast light alloy; for mounting position IM B3: with inserted feet which can be mounted on **three sides** for sizes 90 ... 160S.

Drive end (or flange) and non-drive end endshield in cast iron or light alloy (see following table).

«Supported» **tightening attachments** of endshields and flanges fitted on housing with «tight» coupling.

Ball bearings (see table beside) lubricated «for life» assuming pollution-free surroundings; preload spring.

Steel **driving shaft** C45; on request «Driving shaft axially fastened» (on rear endshield); cylindrical shaft ends with A-shape (rounded) key and tapped butt-end hole (see table, where: d = tapped butt-end hole; b × h × l = key dimensions).

Rear tapped hole for dismounting in applications with gear reducer, as standard for sizes 90 ... 160S.

Motor size	Endshield material and bearings			
	drive end		non-drive end	
63	LL	6202 2Z	6202 2Z	LL
71	LL	6203 2Z	6203 2Z	LL
80	LL	6204 2Z	6204 2Z	LL
90	LL	6205 2Z	6205 2Z	LL
100	LL	6206 2Z	6206 2Z	LL
112	LL	6306 2Z	6306 2Z	LL
132	LL ¹⁾	6308 2Z	6308 2Z	LL
160S	G	6309 2Z	6308 2Z	LL

LL = light alloy G = cast iron

1) Cast iron for IM B14 and IM B5 derivatives.

	Shaft end - Ø × E							
	Ø 9×20	Ø 11×23	Ø 14×30	Ø 19×40	Ø 24×50	Ø 28×60	Ø 38×80	Ø 42×110
d	M3	M4	M5	M6	M8	M10	M12	M16
b×h×l	3×3×12	4×4×18	5×5×25	6×6×32	8×7×40	8×7×50	10×8×70	12×8×100

Steel fan cover.

Thermoplastic **cooling fan** with radial blades.

Terminal box in light alloy (integral with housing with knockout cable openings on both sides, two openings per side, one for power and one for auxiliary equipment).

Position opposite to feet for mounting position IM B3; on request available on right or left side (see ch. 3.9.(14)). Pressure diecast light alloy (63 ... 160S).

Terminal block with 6 terminals (9 terminals for YY230 Y 460 60 Hz) voltage supply; terminal dimensions in the table on the side.

Motor size	Terminal block		Seal rings
	terminals ¹⁾	cable entry ²⁾	
63	M4	4 × M16	15 × 30 × 4,5
71	M4	2 × M16 + 2 × M20	17 × 32 × 5
80	M4	2 × M16 + 2 × M20	20 × 35 × 7
90	M5	2 × M16 + 2 × M25	25 × 46 × 7
100, 112	M5	2 × M16 + 2 × M25	30 × 50 × 7
132	M6	2 × M16 + 2 × M32	40 × 60 × 10
160S	M6	2 × M16 + 2 × M32	45 × 65 × 10 ³⁾

1) 6 terminals for cable terminal connection.

2) Terminal box provided with knockout openings, cable gland not supplied.

3) Non-drive end: 40x60x10.

Earth terminal located inside terminal box; prearranged for the installation of a two further external earth terminal on housing.

Rotor: pressure diecast cage.

Stator winding with class H copper conductor insulation, insulated with double coat, type of impregnation with resin of class H; other materials are of classes F and H for a **class F insulation**.

Materials and type of impregnation allow **use in tropical climates** without further treatment.

Rotor dynamic balancing: vibration velocity under standard rating A. Motors are balanced with half key inserted into shaft extension.

Paint: water-soluble enamel, colour blue RAL 5010 DIN 1843, unaffected by normal industrial environments and suitable for further finishings with single-compound synthetic paints.

For **non-standard designs** and accessories see ch. 3.9.

Compliance with European Directives

Motors of present catalog comply with following standards EN 60034-1, EN 60034-2, EN 60034-2-1, EN 60034-5, EN 60034-6, EN 60034-7, EN 60034-8, EN 60034-9, EN60034-12, EN 60034-14, IEC 60038, IEC 60072-1, and with **Low Voltage Directive 2014/35/EU** (repealing the old 73/23/EC). For this reason the electric motors are CE marked.

Additional information:

The motor design, considering the motors as components, complies with:

- Machinery Directive 2006/42/EC when the installation is correctly executed by machinery manufacturer (e.g.: in compliance with our installation instructions and EN 60204 «Electric Equipments of Industrial Machines»);
- Directive 2011/65/EC RoHS relevant to the limit of use of dangerous substances in the electric and electronic equipments;
- Directive «ErP» 2009/125/CE establishing a framework for the setting of ecodesign requirements for energy-related products; on the base of the field of application, the motor are in conformity with requirements set in Regulation N° 640/2009 and subsequent modification N°2019/1781, the efficiency class is defined according to the Standard EN 60034-30.

Declaration of Incorporation (Directive 2006/42/EC Art 3.2 – II B):

The above mentioned motors must be commissioned as soon as the machines in which they have been incorporated have been declared to be in compliance with the Machinery Directive.

According to EN60034-1, as motors are components and not machines, supplied directly to the final user, the Electromagnetic Compatibility Directive (application of Directive 2014/30/EU) is not directly applicable.

3.4

Radial and axial loads on shaft end

Radial loads generated on the shaft end by a drive connecting motor and driven machine must be less than or equal to those given in the relevant table.

The radial load F_r given by the following formula refers to most common drives:

$$F_r = \frac{k \cdot 19100 \cdot P}{n \cdot d} \text{ [N]}$$

where:

P [kW] is required motor power

n [min^{-1}] is the speed

d [m] is the pitch diameter

k is a coefficient assuming different values according to the drive type:

$k = 1$ for chain drive

$k = 1,1$ for gear pair drive

$k = 1,5$ for timing belt drive

$k = 2,5$ for V-belt drive

The table shows the maximum permissible values of radial and axial loads on driving shaft end (F_r , overhung load on centre line of shaft end), calculated for a bearing life $L_h = 18000$ h. For a longer bearing life, the values stated in the table must be multiplied by:

0,9 (25000 h),

0,8 (35500 h)

or 0,71 (50000 h)

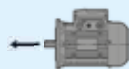
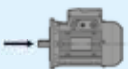
Motor size	$F_r^{(1)}$ [N]				$F_a^{(2)}$ [N]							
												
	n_N [min^{-1}]				n_N [min^{-1}]				n_N [min^{-1}]			
	3000	1500	1000	750	3000	1500	1000	750	3000	1500	1000	750
63	420	530	600	670	200	290	350	400	210	290	350	400
71	510	640	740	810	210	310	380	440	210	310	380	440
80	650	830	950	1050	230	350	420	500	370	500	600	680
90S	710	900	1040	1140	250	390	490	570	250	390	490	570
90L	730	930	1050	1180	240	380	480	560	240	380	480	560
100	1000 ³⁾	1300	1500	1650	300	490	620	730	370	570	710	820
112	1500 ³⁾	1900	2150	2400	660	950	1150	1310	660	950	1150	1310
132	2000 ³⁾	2500	3000	3250	1220	1650	1960	2200	1220	1650	1960	2200
160S	2500	3150	3650	4050	1720	2280	2670	2990	1220	1650	1960	2200

1) An axial load of up to 0,2 times the value in the table is permissible, simultaneously with the radial load.

2) Comprehensive of a possible unfavourable effect of weight-force of rotor and bearing preload spring.

3) For radial load value near to table limit require C3 bearings.

For running at 60 Hz, table values must be reduced by 6%.

This page is intentionally left blank.

3.5

Technical data 400V 50Hz

2 poles - 3000 min⁻¹

IP 55

IC 411

Insulation class F

Temperature rise class B

IE2 P_N 0,12 ... 0,55 kW

P_N ≥ 0,75 kW S3 70%

400V - 50Hz

ErP

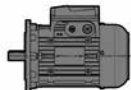

UT.C. 1371

P _N kW	Motor	n _N min ⁻¹	M _N N m	I _N A 400 V	cos φ	η IEC 60034-2-1			M _S / M _N	M _{max} / M _N	I _S / I _N	J ₀ kg m ²	z ₀ starts/h	
						100%	75%	50%						
0,18	HB2 63 A 2	2800	0,61	0,56	0,71	68,7	66,6	60,7	3,1	3,3	4,1	0,0002	4750	3,7
0,25	HB2 63 B 2	2780	0,86	0,75	0,71	70,5	68,9	63,1	3,1	3,2	4,1	0,0002	4750	4,3
0,37 *	HB2 63 C 2	2790	1,26	1,02	0,72	73,3	72,4	67,3	3,5	3,3	4,5	0,0003	4000	4,9
0,37	HB2 71 A 2	2800	1,26	0,95	0,77	75	74,7	70,8	3,1	3,3	5,2	0,0003	4000	5,9
0,55	HB2 71 B 2	2820	1,86	1,33	0,78	77,3	76,9	72,9	3,6	3,7	5,8	0,0004	4000	6,7
0,75 *	HB 71 C 2	2830	2,53	1,85	0,79	73,8	72,9	68,7	3,5	3,7	5,7	0,00049	3000	7,3
0,75	HB 80 A 2	2850	2,51	1,85	0,75	78,3	77,7	74,3	3,6	3,8	6,1	0,00079	3000	7,8
1,1	HB 80 B 2	2840	3,7	2,6	0,77	79,5	80,1	78,3	3,6	3,8	6,1	0,00094	3000	8,6
1,5 *	HB 80 C 2	2890	4,96	3,5	0,76	81,2	81,4	78,9	4	4,4	7,4	0,00124	2500	10,6
1,85 *	HB 80 D 2	2820	6,3	4,2	0,8	79,8	81,2	80,1	3,7	3,8	6,2	0,00134	2500	11,1
1,5	HB 90 S 2	2840	5	3,4	0,81	78,5	78,9	77	3	3,2	5,7	0,00144	2500	13,1
1,85 *	HB 90 SB 2	2860	6,2	4,2	0,8	79,3	79,6	77,1	3,2	4	6,1	0,00164	2500	14,6
2,2	HB 90 LA 2	2880	7,3	4,9	0,8	81	80,7	78	3,8	4,5	7	0,00137	2500	17
3 * □	HB 90 LB 2	2870	10	6,6	0,8	82	82,2	80,1	3,7	4,1	6,8	0,00245	1800	19
3	HB 100 LA 2	2860	10	6,8	0,78	81,5	82	80,1	3,6	3,8	6	0,00315	1800	20
4 *	HB 100 LB 2	2860	13,4	8,8	0,79	83,1	82,5	80	3,8	4,4	7	0,00425	1500	24
4	HB 112 M 2	2880	13,3	8,8	0,79	83,3	83,6	82	3	3,8	6,2	0,00505	1500	27
5,5 * □	HB 112 MB 2	2890	18,2	11,6	0,81	84,7	84,9	83,2	3,3	3,7	7,2	0,00685	1400	31
7,5 * □	HB 112 MC 2	2870	25	16,5	0,79	83	84,4	83,7	3	3,7	6,4	0,00762	1060	33
5,5	HB 132 S 2	2900	18,1	11,3	0,83	84,7	84,3	82,1	2,6	3,4	6,3	0,01017	1250	43
7,5	HB 132 SB 2	2910	24,6	14,3	0,87	86,9	87,2	85,5	2,9	3,7	7,2	0,01357	1120	46
9,2 *	HB 132 SC 2	2910	30,2	18,7	0,82	87	87,3	85,67	3	3,8	7,7	0,01577	1060	48
11 *	HB 132 MA 2	2920	36	20,5	0,88	87,6	87,5	85,9	3,2	3,9	8,3	0,01917	850	55
15 * □	HB 132 MB 2	2920	49,1	30	0,85	88,7	86,2	84	3,7	4,1	8,3	0,02477	710	66
11	HB 160 SA 2	2920	36	20,5	0,88	87,6	87,5	85,9	3,2	3,9	8,3	0,01917	850	64
15 □	HB 160 SB 2	2920	49,1	30	0,83	88,7	86,2	84	3,9	4,3	8,3	0,02477	710	75

Efficiency value not complying with IE3 class range (IEC 60034-30); nominal power and name plate referred to S3 70% intermittent duty.

* Power or motor power-to-size correspondence not according to standard.

□) Temperature rise class F.

Technical data 400V 50Hz

2 poles - 3000 min⁻¹

IP 55

IC 411

Insulation class F

Temperature rise class B

IE3
400V - 50Hz
ErP

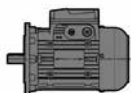

UT.E. 1371

P _N	Motor	n _N	M _N	I _N	cos φ	η			M _S / M _N	M _{max} / M _N	I _S / I _N	J ₀	z ₀	kg
						IE3 IEC 60034-2-1								
kW		min ⁻¹	N m	A 400 V		100%	75%	50%				kg m ²	starts/h	
0,75	HB3 80 A 2	2870	2,5	1,7	0,78	80,7	79,9	76,7	3,6	3,8	7,3	0,0009	2500	8
1,1	HB3 80 B 2	2875	3,7	2,3	0,84	82,7	83,2	81	3,9	3,9	7,7	0,0013	2500	11,6
1,5	HB3 90 S 2	2890	4,97	2,9	0,88	84,2	84,5	83,3	3,3	3,6	7,9	0,0019	1800	16
2,2	HB3 90 LA 2	2890	7,3	4,4	0,85	85,9	86,2	85,1	3,9	4,4	8,4	0,0023	1600	18
3	HB3 100 LA 2	2930	9,8	6,2	0,80	87,1	87,2	85,2	4,2	5,1	10,1	0,0044	1500	24
4	HB3 112 M 2	2940	13	7,6	0,87	88,1	88,2	86,7	2,8	4,2	9,8	0,0074	1400	33
5,5	HB3 132 S 2	2960	17,8	10,4	0,85	89,2	88,6	85,6	5,2	6,1	12,7	0,0174	710	53
7,5	HB3 132 SB 2	2960	24,3	14	0,85	90,1	89,9	87,3	5,7	6,5	13,6	0,0215	710	61,5
9,2 *	HB3 132 SC 2	2960	29,7	17,3	0,84	90,7	89,9	87,4	5,7	6,3	13,4	0,0243	710	67
11 *	HB3 132 MA 2	2950	35,7	20	0,87	91,2	90,1	88,4	5,2	4,9	11,6	0,0243	710	67
11	HB3 160 SA 2	2950	35,7	20	0,87	91,2	90,1	88,4	5,2	4,9	11,6	0,0243	710	76

* Power or motor power-to-size correspondence not according to standard.

3.5

Technical data 400V 50Hz

4 poles - 1500 min⁻¹

IP 55

IC 411

Insulation class F

Temperature rise class B

IE2 P_N 0,12 ... 0,55 kW

P_N ≥ 0,75 kW S3 70%

400V - 50Hz

ErP

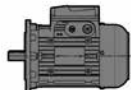

UT.C. 1371

P _N kW	Motor	n _N min ⁻¹	M _N N m	I _N A 400 V	cos φ	η IEC 60034-2-1			M _S / M _N	M _{max} / M _N	I _S / I _N	J ₀ kg m ²	z ₀ starts/h	
						100%	75%	50%						
0,12	HB2 63 A 4	1370	0,84	0,46	0,63	61,4	58,9	51,9	2,5	2,6	3,1	0,0002	12500	3,9
0,18	HB2 63 B 4	1350	1,28	0,64	0,66	65	64,1	58,4	2,6	2,5	3,3	0,0003	12500	4,5
0,25 *	HB2 63 C 4	1360	1,76	0,83	0,65	68,5	67,8	62,8	2,8	2,7	3,5	0,0004	10000	5,2
0,25	HB2 71 A 4	1400	1,71	0,8	0,71	68,5	66,6	60,7	2,3	2,6	3,8	0,0007	10000	5,7
0,37	HB2 71 B 4	1400	2,52	1,1	0,70	73,2	72,2	67,3	2,7	3,2	4,6	0,0009	10000	6,6
0,55 *	HB2 71 C 4	1400	3,75	1,5	0,70	77,1	75,7	72	3,3	3,5	5,1	0,00129	8000	8,3
0,75 *	HB 71 D 4	1370	5,2	2,15	0,70	72,1	73,3	69,1	2,8	2,9	4	0,00129	7100	8,3
0,55	HB2 80 A 4	1420	3,69	1,34	0,78	77,1	76	72	2,9	3,1	5,8	0,00234	8000	9,1
0,75	HB 80 B 4	1410	5,1	1,9	0,77	74,7	74,2	70,5	2,8	3,0	5,2	0,00234	7100	9,1
1,1 *	HB 80 C 4	1400	7,5	2,8	0,79	75	75,6	72	2,9	3,0	5,2	0,00314	5000	11,1
1,1	HB 90 S 4	1410	7,4	3	0,70	75,2	74,7	70	2,6	2,9	4,4	0,00234	5000	13,1
1,5	HB 90 L 4	1410	10,2	3,9	0,71	77,2	79	74,5	3,2	3,6	5,2	0,00335	4000	16
1,85 *	HB 90 LB 4	1400	12,6	4,5	0,76	78,6	80	77,1	2,9	3,2	5,1	0,00365	4000	17
2,2 * □	HB 90 LC 4	1400	15	5,7	0,70	79,7	80,3	77,2	2,8	3,2	4,9	0,00415	3150	18,5
2,2	HB 100 LA 4	1420	14,8	5,1	0,78	80	80,8	79,2	2,7	3,2	5,1	0,00505	3150	20
3	HB 100 LB 4	1425	20,1	6,9	0,76	82,8	83,7	82	2,8	3,2	5,5	0,00685	3150	24
4	HB 112 M 4	1430	26,7	9,2	0,75	83,4	84,1	82,6	3,0	3,4	6	0,01082	2500	30
5,5 * □	HB 112 MC 4	1420	37	12,3	0,76	84,7	86,1	85,7	3,0	3,4	6,1	0,01302	1800	33
5,5	HB 132 S 4	1450	36,2	12,2	0,76	86,3	86,9	85,7	3,2	3,4	6,3	0,02347	1800	45
7,5	HB 132 M 4	1450	49,4	15,8	0,79	87,1	87,7	86,5	3,4	3,6	7	0,03197	1250	54
9,2 *	HB 132 MB 4	1450	61	19,5	0,77	88	89,4	87,6	3,5	3,8	7,2	0,03765	1060	60
11 * □	HB 132 MC 4	1450	72	23	0,78	87,8	88,2	87	3,5	3,8	7,3	0,04325	900	66
11 □	HB 160 SC 4	1450	72	23	0,78	87,8	88,2	87	3,5	3,8	7,3	0,04325	900	75

Efficiency value not complying with IE3 class range (IEC 60034-30); nominal power and name plate referred to S3 70% intermittent duty.

* Power or motor power-to-size correspondence not according to standard.

□) Temperature rise class F.

Technical data 400V 50Hz

4 poles - 1500 min⁻¹

IP 55

IC 411

Insulation class F

Temperature rise class B

IE3
400V - 50Hz
ErP

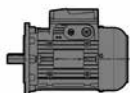

UT.E. 1371

P_N	Motor	n_N	M_N	I_N	$\cos \varphi$	η			M_S / M_N	M_{max} / M_N	I_S / I_N	J_0	z_0	kg
						IE3 IEC 60034-2-1								
kW		min ⁻¹	N m	A 400 V		100%	75%	50%				kg m ²	starts/h	
0,75	HB3 80 B 4	1410	5,1	2	0,67	82,5	82,2	80,1	3,2	3,3	5,3	0,0018	6800	12
1,1	HB3 90 S 4	1420	7,4	2,4	0,80	84,1	84,8	83,6	3,0	3,5	6,4	0,0041	3150	18,5
1,5	HB3 90 L 4	1430	10,1	3,3	0,78	85,3	86,1	85	3,1	3,7	6,7	0,0043	3000	19
1,85 ¹⁾	HB3 90 LB 4	1425	12,4	4,3	0,73	86	85,3	83,4	3,4	3,7	6,4	0,0043	3000	19
2,2	HB3 100 LA 4	1440	14,6	4,8	0,76	86,7	87,2	85,5	3,5	4,4	7,4	0,0076	3000	26
3 *	HB3 112 MA 4	1450	19,8	6,1	0,80	88,7	88,6	87,3	3,5	4,4	8,8	0,013	2000	33
4	HB3 112 M 4	1450	26,3	8,5	0,77	88,6	89,2	88	3,7	4,6	9,0	0,014	1800	35
5,5	HB3 132 S 4	1470	35,8	12	0,74	89,6	89,5	87,6	4,5	5,0	9,1	0,0357	900	58
7,5	HB3 132 M 4	1460	49	15,2	0,79	90,4	90,4	89,6	3,9	4,2	8,4	0,0432	900	66
9,2 *	HB3 132 MB 4	1460	60,2	19,2	0,76	91	90,8	90,1	4,0	4,1	8,5	0,0448	800	68,5

* Power or motor power-to-size correspondence not according to standard.

1) Available only for voltages at 50 Hz

3.5

Technical data 400V 50Hz

6 poles - 1000 min⁻¹

IP 55

IC 411

Insulation class F

Temperature rise class B

IE2 P_N 0,12 ... 0,55 kW

P_N ≥ 0,75 kW S3 70%

400V - 50Hz

ErP

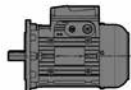

UT.C. 1371

P _N kW	Motor			n _N min ⁻¹	M _N N m	I _N A 400 V	cos φ	η			M _S / M _N	M _{max} / M _N	I _S / I _N	J ₀ kg m ²	z ₀ starts/h	
								IEC 60034-2-1								
							100%	75%	50%							
0,09	HB	63 A	6	900	0,95	0,48	0,57	47,6	43,1	34,4	2,5	2,6	2,3	0,0004	13200	4,1
0,12	HB2	63 B	6	900	1,27	0,55	0,59	52,2	48,3	40,1	2,7	2,8	2,5	0,0005	12500	4,5
0,15 *	HB2	63 C	6	875	1,64	0,62	0,64	55,6	53,2	46	2,5	2,5	2,6	0,0005	11800	5,1
0,18	HB2	71 A	6	900	1,91	0,66	0,67	59,5	57,1	49,8	2,4	2,4	3	0,0009	12500	6
0,25	HB2	71 B	6	900	2,64	0,88	0,67	61,8	59,7	52,9	2,5	2,7	3,3	0,0012	11200	6,8
0,37 *	HB2	71 C	6	895	3,95	1,2	0,69	67,6	66,1	61	2,6	2,3	3,5	0,0017	10000	8,2
0,37	HB2	80 A	6	910	3,9	1,2	0,67	67,6	64	57,8	2,7	2,6	3,6	0,0019	9500	8
0,55	HB2	80 B	6	930	5,6	1,6	0,67	73,1	72,2	67,7	3	3	4,5	0,00314	9000	11,1
0,75 *	HB	80 C	6	920	7,8	2,3	0,67	70,1	69,7	64,5	2,5	2,7	3,8	0,00314	7100	11,1
0,75	HB	90 S	6	920	7,8	2,2	0,68	72,1	72	67,9	2,4	2,4	3,7	0,00404	7100	13,6
1,1	HB	90 L	6	915	11,5	3,2	0,68	72,9	72	69,3	2,6	2,8	3,9	0,00555	5300	17
1,5 * □	HB	90 LC	6	910	15,7	4,3	0,68	73,8	72,5	70	2,7	2,9	4,3	0,00655	5000	18,5
1,5	HB	100 LA	6	930	15,4	3,9	0,73	75,5	75,4	71,6	2,8	3	4,8	0,00955	3550	21
1,85 *	HB	100 LB	6	930	19	4,9	0,71	76,6	76,2	72,1	3	3,2	5	0,01175	3150	24
2,2	HB	112 M	6	940	22,3	5,4	0,75	78,7	79,7	78,1	2,1	2,5	6,5	0,01482	2800	27
3 * □	HB	112 MC	6	940	30,5	7,2	0,76	79,7	81,2	80,2	2,3	2,7	5,1	0,01882	2500	32
3	HB	132 S	6	960	29,8	7,8	0,68	82,1	82,3	80,2	2,3	3	6	0,02947	2360	42
4	HB	132 M	6	960	39,8	9,7	0,72	83,2	83,7	81,8	2,5	3	6,7	0,03837	1400	49
5,5	HB	132 MB	6	960	55	12,9	0,73	84	84,8	83,4	2,6	3	7	0,04865	1250	58
7,5 * □	HB	132 MC	6	950	75	17,6	0,73	84,7	85	83,8	2,4	2,8	5,7	0,05885	1000	66
7,5 □	HB	160 SC	6	950	75	17,6	0,73	84,7	85	83,8	2,4	2,8	5,7	0,05885	1000	75

Efficiency value not complying with IE3 class range (IEC 60034-30); nominal power and name plate referred to S3 70% intermittent duty.

* Power or motor power-to-size correspondence not according to standard.

□) Temperature rise class F.

Technical data 400V 50Hz 460V 60Hz

6 poles - 1000 min⁻¹ 50Hz
1200 min⁻¹ 60Hz

IP 55

IC 411

Insulation class F

Temperature rise class B

IE3
400V - 50Hz
460V - 60Hz
ErP

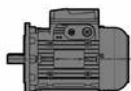

UT.C 1371

Supply	P_N kW	Motor	n_N min ⁻¹	M_N N m	I_N A 400 V	$\cos \varphi$	η IE3 IEC 60034-2-1			M_S / M_N	M_{max} / M_N	I_S / I_N	J_0 kg m ²	z_0 starts/h	
							100%	75%	50%						
Y 400 V 50 Hz 1)	0,75	HB3 90 S 6	930	7,7	2	0,72	78,9	76	73	2,1	2,9	4,9	0,0056	6000	15,5
	1,1	HB3 90 L 6	930	11,3	2,8	0,72	81	79	77	2,6	3	5,1	0,0071	5600	19,5
	1,5	HB3 100 LA 6	950	15,1	3,5	0,75	82,5	82,4	80,4	2,5	3,4	6,5	0,013	3000	26
	2,2	HB3 112 M 6	960	21,9	5,1	0,73	84,3	85	83,2	2,3	3,5	6,9	0,0202	2800	33
	3	HB3 132 S 6	970	29,5	6,9	0,72	85,6	88	86,3	2,4	3,8	7,6	0,0435	1400	54
	4	HB3 132 M 6	970	39,4	9,2	0,71	86,8	88,3	86,3	2,8	4,4	8,4	0,0589	1250	66
Y 460 V 60 Hz 2)	0,75 *	HB3 100 LA 6	1160	6,1	1,6	0,71	82,5	84,2	80,9	2,9	4,4	7,9	0,013	3200	26
	1,1 *	HB3 112 M 6	1160	9,1	2,2	0,73	87,5	88,2	86,8	2,5	3,4	6,3	0,0215	2500	34
	1,5 *	HB3 112 MB 6	1160	12,3	3,1	0,70	88,5	88,2	86,5	3,0	3,9	6,9	0,0215	2000	34
	2,2 *	HB3 132 S 6	1170	18	4,3	0,72	89,5	89,9	88,4	2,7	3,6	7,3	0,0358	1400	47
	3 *	HB3 132 M 6	1170	24,5	5,8	0,72	89,5	90,2	88,7	2,8	3,8	7,6	0,0461	1000	56
	4	HB3 132 MB 6	1170	32,6	7,9	0,70	89,5	91	89,5	3,1	4,1	8,0	0,06	800	67

1) Motor Size-power combinations available with name plate at 50 Hz only (for other voltage see ch. 3.9 (1)).

2) Motor Size-power combinations available with name plate at 60 Hz only (for other voltage see ch. 3.9 (1)).

* Power or motor power-to-size correspondence not according to standard.

3.6

Technical data 230.460V 60Hz

4 poles - 1800 min⁻¹

IP 55

IC 411

Insulation class F

Temperature rise class B

Service factor **SF 1,15**

9 terminals

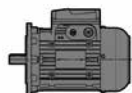

U.F.C. 1371

IE2 P_N 0,16 ... 0,75 hp

P_N ≥ 1 hp S3 70%

ErP

230.460V - 60Hz²⁾

NEMA MG1-12

P _N	Motor	n _N	M _N	I _N		PF	NEMA Nom. Eff.	NEMA Code	M _S / M _N	M _{max} / M _N	I _S / I _N	J ₀	z ₀	
				A	A									
1)		1)		230 V	460 V	1)	MG 1-12					kg m ²	starts/h	
hp		RPM	N m			%	%							
0,16	HB2 63 A 4	1690	0,68	0,84	0,42	58	64	J	3,1	3,1	3,6	0,0002	10000	3,9
0,25	HB2 63 B 4	1680	1,02	1,18	0,59	60	69	J	3,3	3,1	3,8	0,0003	10000	4,5
0,33	HB2 63 C 4	1690	1,42	1,5	0,75	59	72,3	J	3,5	3,5	4,2	0,0004	8000	5,2
0,33	HB2 71 A 4	1720	1,39	1,4	0,7	65	70,9	K	2,8	3,3	4,8	0,0007	8000	5,7
0,5	HB2 71 B 4	1720	2,06	1,9	0,95	65	76	K	3,1	3,8	5,3	0,0009	8000	6,6
0,75	HB2 71 C 4	1720	3,06	2,6	1,3	66	78,8	K	4	4,1	6,3	0,0013	6300	8,3
1	HB 71 D 4	1680	4,23	3,8	1,9	65	77	J	3,4	3,5	4,8	0,0013	5600	8,3
0,75	HB2 80 A 4	1740	3	2,4	1,2	74	78,4	L	3,3	3,7	7,2	0,0021	6300	9,1
1	HB 80 B 4	1720	4,14	3,4	1,7	70	78,5	K	3,2	3,5	6,2	0,0021	5600	9,1
1,5	HB 80 C 4	1720	6,2	5	2,5	76	80	J	3,6	3,7	5,7	0,0032	4000	11,1
1,5	HB 90 S 4	1720	6,2	5,4	2,7	68	80	J	3	3,3	5,3	0,0024	4000	13,1
2	HB 90 L 4	1730	8,3	7	3,5	68	81,5	H	3,6	4,2	6	0,0034	3150	16
2,4	HB 90 LB 4	1710	10,4	8	4	70	84	J	3,6	4,0	5,6	0,0036	3150	17
3	HB 90 LC 4	1700	12,6	10	5	70	84	J	3,3	3,8	5,4	0,0041	2500	18,5
3	HB 100 LA 4	1730	12,3	9,2	4,6	74	85,5	J	3,1	3,7	6,1	0,0051	2500	20
4	HB 100 LB 4	1730	16,4	12,4	6,1	73	85,5	K	3,2	3,7	6,6	0,0069	2500	24
5,4	HB 112 M 4	1740	22,1	16	8	72	85,5	J	3,4	3,9	6,5	0,0108	2000	30
7,5	HB 112 MC 4	1740	30,7	22,5	11,2	75	87,5	K	3,7	4,2	6,7	0,013	1400	33
7,5	HB 132 S 4	1750	30,5	21	10,6	74	87,5	K	3,7	3,9	7,5	0,0235	1400	45
10	HB 132 M 4	1750	40,7	27,5	13,7	77	87,5	K	3,9	4,1	7,8	0,032	1000	54
12,4	HB 132 MB 4	1760	51	35,4	17,7	75	87,5	K	4,0	4,4	8,0	0,0376	850	60
15	HB 132 MC 4	1760	61	41	20,5	76,4	89,5	K	4,2	4,7	8,0	0,0432	710	66

Efficiency value not complying with IE2 class range EISA Premium Efficiency (EISA 2007 CSA C390-1); nominal power and name plate referred to S3 70% intermittent duty.

1) The nameplate contains data expressed in: hp, rpm, PF (power factor) in %.

2) Other supply are available on request, see ch. 3.9 (1).

*) Power or motor power-to-size correspondence not according to standard.

□) Temperature rise class F.

Technical data 230.460V 60Hz

4 poles - 1800 min⁻¹

IP 55

IC 411

Insulation class F

Temperature rise class B

Service factor **SF 1,15**

9 terminals

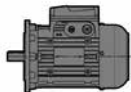

U.T.C. 1371

Premium Efficiency (IE3)
230.460V - 60Hz ²⁾
EISA
 CC131B

In accordance with US DOE 10 CFR 431 and CSA C390 EISA ACT December 19, 2017

P_N		Motor	n_N	M_N	I_N		PF	NEMA Nom. Eff. MG 1-12	NEMA Code	M_S / M_N	M_{max} / M_N	I_S / I_N	J_0	z_0	kg
hp	kW				A 230 V	A 460 V									
1	0,75 *	HB3 90 S 4	1740	4,1	3	1,5	73	85,5	K	3,4	4,3	7,2	0,0032	3150	15,5
1,5	1,1 *	HB3 90 L 4	1740	6,1	4,2	2,1	75	86,5	K	3,4	4,1	7,7	0,0043	2500	18,5
2	1,5	HB3 90 LB 4	1740	8,3	5,8	2,9	75	86,5	L	3,4	4,4	7,9	0,0043	2500	18,5
3	2,2 *	HB3 112 MA 4	1760	12	8	4	78	89,5	M	3,9	5,1	9,6	0,012	2000	31
4	3 *	HB3 112 M 4	1750	16,3	10,6	5,3	79	89,5	M	4,1	5,4	9,4	0,013	1600	33
5,4	4	HB3 112 MB 4	1760	21,8	15	7,5	75	89,5	N	4,0	5,5	10,3	0,014	1400	35
7,5	5,5 *	HB3 132 M 4	1770	29,7	19	9,5	79	91,7	L	4,1	4,4	9,7	0,0357	710	58
10	7,5	HB3 132 MB 4	1760	40,6	25,8	12,9	79	91,7	L	3,7	4,4	9,1	0,0448	710	68,5
12,3	9,2	HB3 132 MC 4	1765	49,9	33,8	16,9	74	91,7	M	4,3	4,4	8,7	0,0448	710	68,5

1) The nameplate contains data expressed in: hp, rpm, PF (power factor) in %.

2) On request other voltage are possible:

255.440V - 60Hz, 265.460V - 60 Hz and 277.480V - 60Hz.

440V (Δ) - 60 Hz, 460V (Δ) - 60 Hz and 480V (Δ) - 60 Hz.

*) Power or motor power-to-size correspondence not according to standard.



3.6

Technical data 230.460V 60Hz

6 poles - 1200 min⁻¹
 IP 55
 IC 411
 Insulation class F
 Temperature rise class B
 Service factor **SF 1,15**
 9 terminals

IE2 P_N 0,16 ... 0,75 hp

P_N ≥ 1 hp S3 70%

ErP    **US**

230.460V - 60Hz ²⁾

NEMA MG1-12

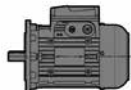

U.F.C. 1371

P _N		Motor	n _N	M _N	I _N		PF	NEMA Nom. Eff.	NEMA Code	M _S / M _N	M _{max} / M _N	I _S / I _N	J ₀	z ₀	
1)					A	A									
hp	kW		RPM	N m	230 V	460 V	%	%					kg m ²	starts/h	
0,12	0,09	HB 63 A 6	1120	0,76	0,88	0,44	52	52,5	J	2,9	3,0	2,7	0,0004	10600	4,1
0,16	0,12	HB2 63 B 6	1120	1,02	1,04	0,52	53	55,8	J	3,1	3,2	2,9	0,0005	10000	4,5
0,20	0,15 *	HB2 63 C 6	1100	1,3	1,2	0,6	56	58	J	3,1	3,2	3	0,0005	9500	5,1
0,25	0,18	HB2 71 A 6	1120	1,53	1,22	0,61	60	62,6	H	3	3,1	3,6	0,0009	10000	6
0,33	0,25	HB2 71 B 6	1120	2,1	1,62	0,81	60	64,9	J	3,1	3,1	3,9	0,0012	9000	6,8
0,5	0,37 *	HB2 71 C 6	1120	3,16	2,2	1,1	63	70,9	J	3,2	3,3	4,5	0,0017	8000	8,2
0,5	0,37	HB2 80 A 6	1130	3,12	2,2	1,1	61	68,4	J	3,3	3,5	4,3	0,0019	7500	8
0,75	0,55	HB2 80 B 6	1140	4,6	3	1,5	62	75,7	K	3,6	3,7	5,3	0,0032	7100	11
1	0,75 *	HB 80 C 6	1130	6,3	4	2	62	75,5	J	2,9	3,1	4,6	0,0032	5600	11
1	0,75	HB 90 S 6	1130	6,3	3,8	1,9	66	75,5	H	2,8	3	4,5	0,0041	4500	13,6
1,5	1,1	HB 90 L 6	1130	9,4	5,6	2,8	67	75,5	H	3,0	3,2	4,7	0,0056	4250	17
2	1,5 *	<input type="checkbox"/> HB 90 LC 6	1120	12,7	7,6	3,8	64	77	J	3,1	3,3	5,2	0,0066	4000	18,5
2	1,5	HB 100 LA 6	1140	12,5	7	3,5	68	80	K	3,2	3,4	5,8	0,0096	2240	21
2,4	1,85 *	HB 100 LB 6	1140	15,6	8,6	4,3	68	80	K	3,4	3,6	6,0	0,0117	2500	24
3	2,2	HB 112 M 6	1150	18,6	9,4	4,7	72	82,5	J	2,4	2,9	6,0	0,0148	2240	27
4	3 *	<input type="checkbox"/> HB 112 MC 6	1150	24,7	12,4	6,2	73	84	J	2,6	3,1	6,1	0,0189	2000	32
4	3	HB 132 S 6	1160	24,5	13,8	6,9	64	85,5	K	2,6	3,4	6,1	0,0295	1600	42
5,4	4	HB 132 M 6	1160	33,1	17,2	8,6	70	85,5	K	2,9	3,4	6,9	0,0384	1060	49
7,5	5,5	HB 132 MB 6	1160	46	23	11,4	72	86,5	L	3,0	3,4	7,5	0,0486	1000	58
10	7,5 *	<input type="checkbox"/> HB 132 MC 6	1150	62	31	15,5	70	86,5	K	2,7	3,2	6,9	0,0589	800	66
10	7,5	<input type="checkbox"/> HB 160 SC 6	1150	62	31	15,5	70	86,5	K	2,7	3,2	6,9	0,0589	800	75

Efficiency value not complying with IE2 class range EISA Premium Efficiency (EISA 2007 CSA C390-1); nominal power and name plate referred to S3 70% intermittent duty.

1) The nameplate contains data expressed in: hp, rpm, PF (power factor) in %.

2) Other supply are available on request, see ch. 3.9 (1).

* Power or motor power-to-size correspondence not according to standard.

Temperature rise class F.

Technical data 230.460V 60Hz

6 poles - 1200 min⁻¹

IP 55

IC 411

Insulation class F

Temperature rise class B

Service factor **SF 1,15**

9 terminals

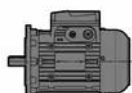

U.T.C. 1371

Premium Efficiency (IE3)
230.460V - 60Hz ²⁾

EISA



In accordance with US DOE 10 CFR 431
and CSA C390 EISA ACT
December 19, 2017

P_N		Motor	n_N	M_N	I_N		PF	NEMA Nom. Eff.	NEMA Code	M_S / M_N	M_{max} / M_N	I_S / I_N	J_0	z_0	
1)					A	A									
hp	kW		RPM	N m	230 V	460 V	%	%					kg m ²	starts/h	
1	0,75 *	HB3 100 LA 6	1160	6,1	3,2	1,6	71	82,5	M	2,9	4,4	7,9	0,013	3200	26
1,5	1,1 *	HB3 112 M 6	1160	9,1	4,4	2,2	73	87,5	J	2,5	3,4	6,3	0,0215	2500	34
2	1,5 *	HB3 112 MB 6	1160	12,3	6,2	3,1	70	88,5	K	3,0	3,9	6,9	0,0215	2000	34
3	2,2 *	HB3 132 S 6	1170	18	8,6	4,3	72	89,5	K	2,7	3,6	7,3	0,0358	1400	47
4	3 *	HB3 132 M 6	1170	24,5	11,6	5,8	72	89,5	K	2,8	3,8	7,6	0,0461	1000	56
5,4	4	HB3 132 MB 6	1170	32,6	15,8	7,9	70	89,5	L	3,1	4,1	8,0	0,06	800	67

1) The nameplate contains data expressed in: hp, rpm, PF (power factor) in %.

2) On request other voltage are possible:

255.440V - 60Hz, 265.460V - 60 Hz and 277.480V - 60Hz.

* Power or motor power-to-size correspondence not according to standard.

3.7

Technical data 380V 60Hz

4 poles - 1700 min⁻¹

IP 55

IC 411

Insulation class F

Temperature rise class B

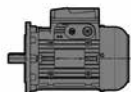

UT.C. 1371

P _N kW	Motor			n _N min ⁻¹	M _N N m	I _N A 380 V	cos φ	η IEC 60034-2-1			M _S / M _N	M _{max} / M _N	I _S / I _N	J ₀ kg m ²	z ₀ avv./h	
	HB3	80B	4					100%	75%	50%						
0,75	HB3	80B	4	1730	4,1	2,2	0,62	83,5	83,8	81,1	3,7	3,8	6,1	0,0018	5700	12
1,1	HB3	90S	4	1735	6,1	2,6	0,77	86,5	85,5	83,3	3,3	3,7	7,5	0,0041	2500	18,5
1,5	HB3	90L	4	1740	8,3	3,7	0,75	86,5	84,0	82,5	3,4	4,4	7,9	0,0043	2500	18,5
2,2	HB3	100LA	4	1750	12,0	5,2	0,73	89,5	87,7	85,3	4,1	4,6	8,2	0,0076	2360	26
3	* HB3	112MA	4	1760	16,3	6,5	0,77	89,5	89,5	87,5	4,1	4,9	9,2	0,013	1600	33
4	HB3	112M	4	1760	21,8	9,0	0,75	89,5	90,2	88,7	4,0	5,5	10,3	0,014	1400	35
5,5	HB3	132S	4	1770	29,7	12,8	0,71	91,7	90,2	88,2	4,6	5,2	9,8	0,0357	710	58
7,5	HB3	132M	4	1765	40,5	16,0	0,77	91,7	90,9	89,4	4,7	4,9	10,0	0,0432	710	66
9,2	* HB3	132MB	4	1765	49,8	20,5	0,73	92,4	91,8	90,6	4,3	4,4	8,7	0,0448	710	68,5

* Power or motor power-to-size correspondence not according to standard.

Technical data 380V 60Hz

6 poles - 1100 min⁻¹

IP 55

IC 411

Insulation class F

Temperature rise class B

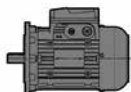

UT.C. 1371

P _N kW	Motor		n _N min ⁻¹	M _N N m	I _N A 380 V	cos φ	η IEC 60034-2-1			M _S / M _N	M _{max} / M _N	I _S / I _N	J ₀ kg m ²	z ₀ avv./h	kg
							100%	75%	50%						
0,75 *	HB3	100LA 6	1160	6,1	1,9	0,71	82,5	84,2	80,9	2,9	4,4	7,9	0,013	3200	26
1,1 *	HB3	112M 6	1160	9,1	2,6	0,73	87,5	88,2	86,8	2,5	3,4	6,3	0,0215	2500	34
1,5 *	HB3	112MB 6	1160	12,3	3,7	0,70	88,5	88,2	86,5	3,0	3,9	6,9	0,0215	2000	34
2,2 *	HB3	132S 6	1170	18,0	5,2	0,72	89,5	89,9	88,4	2,7	3,6	7,3	0,0358	1400	47
3 *	HB3	132M 6	1170	24,5	7,0	0,72	89,5	90,2	88,7	2,8	3,8	7,6	0,0461	1000	56
4	HB3	132MB 6	1170	32,6	9,5	0,70	89,5	91	89,5	3,1	4,1	8,0	0,06	800	67

* Power or motor power-to-size correspondence not according to standard

3.8

Technical data 400V 50Hz

2 poli - 3000 min⁻¹

IP 55

IC 411

Insulation class F

Temperature rise class B

Extra CE
400V - 50Hz
ErP

Motor for extra CE market only

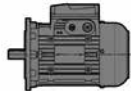

U.T.C. 1371

P _N	Motor		n _N	M _N	I _N	cos φ	η			M _S / M _N	M _{max} / M _N	I _S / I _N	J ₀	z ₀	kg
							IEC 60034-2-1								
							100%	75%	50%						
kW			min ⁻¹	N m	A 400 V							kg m ²	starts/h		
0,75 *	HB	71 C 2	2830	2,53	1,85	0,79	73,8	72,9	68,7	3,5	3,7	5,7	0,00049	3000	7,3
0,75	HB	80 A 2	2850	2,51	1,85	0,75	78,3	77,7	74,3	3,6	3,8	6,1	0,00079	3000	7,8
1,1	HB	80 B 2	2840	3,7	2,6	0,77	79,5	80,1	78,3	3,6	3,8	6,1	0,00094	3000	8,6
1,5 *	HB	80 C 2	2890	4,96	3,5	0,76	81,2	81,4	78,9	4	4,4	7,4	0,00124	2500	10,6
1,85 *	HB	80 D 2	2820	6,3	4,2	0,8	79,8	81,2	80,1	3,7	3,8	6,2	0,00134	2500	11,1
1,5	HB	90 S 2	2840	5	3,4	0,81	78,5	78,9	77	3	3,2	5,7	0,00144	2500	13,1
1,85 *	HB	90 SB 2	2860	6,2	4,2	0,8	79,3	79,6	77,1	3,2	4	6,1	0,00164	2500	14,6
2,2	HB	90 LA 2	2880	7,3	4,9	0,8	81	80,7	78	3,8	4,5	7	0,00137	2500	17
3 * □	HB	90 LB 2	2870	10	6,6	0,8	82	82,2	80,1	3,7	4,1	6,8	0,00245	1800	19
3	HB	100 LA 2	2860	10	6,8	0,78	81,5	82	80,1	3,6	3,8	6	0,00315	1800	20
4 *	HB	100 LB 2	2860	13,4	8,8	0,79	83,1	82,5	80	3,8	4,4	7	0,00425	1500	24
4	HB	112 M 2	2880	13,3	8,8	0,79	83,3	83,6	82	3	3,8	6,2	0,00505	1500	27
5,5 * □	HB	112 MB 2	2890	18,2	11,6	0,81	84,7	84,9	83,2	3,3	3,7	7,2	0,00685	1400	31
7,5 * □	HB	112 MC 2	2870	25	16,5	0,79	83	84,4	83,7	3	3,7	6,4	0,00762	1060	33
5,5	HB	132 S 2	2900	18,1	11,3	0,83	84,7	84,3	82,1	2,6	3,4	6,3	0,01017	1250	43
7,5	HB	132 SB 2	2910	24,6	14,3	0,87	86,9	87,2	85,5	2,9	3,7	7,2	0,01357	1120	46
9,2 *	HB	132 SC 2	2910	30,2	18,7	0,82	87	87,3	85,67	3	3,8	7,7	0,01577	1060	48
11 *	HB	132 MA 2	2920	36	20,5	0,88	87,6	87,5	85,9	3,2	3,9	8,3	0,01917	850	55
15 * □	HB	132 MB 2	2920	49,1	30	0,85	88,7	86,2	84	3,7	4,1	8,3	0,02477	710	66
11	HB	160 SA 2	2920	36	20,5	0,88	87,6	87,5	85,9	3,2	3,9	8,3	0,01917	850	64
15 □	HB	160 SB 2	2920	49,1	30	0,83	88,7	86,2	84	3,9	4,3	8,3	0,02477	710	75

*)Power or motor power-to-size correspondence not according to standard.

□)Temperature rise class F.

Technical data 400V 50Hz

4 poli - 1500 min⁻¹
 IP 55
 IC 411
 Insulation class F
 Temperature rise class B

Extra CE
400V - 50Hz
ErP

Motor for extra CE market only

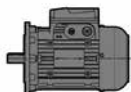

UT.C 1371

P _N	Motor		n _N	M _N	I _N	cos φ	η			M _s / M _N	M _{max} / M _N	I _s / I _N	J ₀	z ₀	kg
							IEC 60034-2-1								
kW			min ⁻¹	N m	A 400 V		100%	75%	50%				kg m ²	starts/h	
0,75 *	HB	71 D 4	1370	5,2	2,15	0,70	72,1	73,3	69,1	2,8	2,9	4,0	0,00129	7100	8,3
0,75	HB	80 B 4	1410	5,1	1,9	0,77	74,7	74,2	70,5	2,8	3,0	5,2	0,00234	7100	9,1
1,1 *	HB	80 C 4	1400	7,5	2,8	0,79	75	75,6	72	2,9	3,0	5,2	0,00314	5000	11,1
1,1	HB	90 S 4	1410	7,4	3	0,70	75,2	74,7	70	2,6	2,9	4,4	0,00234	5000	13,1
1,5	HB	90 L 4	1410	10,2	3,9	0,71	77,2	79	74,5	3,2	3,6	5,2	0,00335	4000	16
1,85 *	HB	90 LB 4	1400	12,6	4,5	0,76	78,6	80	77,1	2,9	3,2	5,1	0,00365	4000	17
2,2 * □	HB	90 LC 4	1400	15	5,7	0,70	79,7	80,3	77,2	2,8	3,2	4,9	0,00415	3150	18,5
2,2	HB	100 LA 4	1420	14,8	5,1	0,78	80	80,8	79,2	2,7	3,2	5,1	0,00505	3150	20
3	HB	100 LB 4	1425	20,1	6,9	0,76	82,8	83,7	82	2,8	3,2	5,5	0,00685	3150	24
4	HB	112 M 4	1430	26,7	9,2	0,75	83,4	84,1	82,6	3,0	3,4	6,0	0,01082	2500	30
5,5 * □	HB	112 MC 4	1420	37	12,3	0,76	84,7	86,1	85,7	3,0	3,4	6,1	0,01302	1800	33
5,5	HB	132 S 4	1450	36,2	12,2	0,76	86,3	86,9	85,7	3,2	3,4	6,3	0,02347	1800	45
7,5	HB	132 M 4	1450	49,4	15,8	0,79	87,1	87,7	86,5	3,4	3,6	7,0	0,03197	1250	54
9,2 *	HB	132 MB 4	1450	61	19,5	0,77	88	89,4	87,6	3,5	3,8	7,2	0,03765	1060	60
11 * □	HB	132 MC 4	1450	72	23	0,78	87,8	88,2	87	3,5	3,8	7,3	0,04325	900	66
11 □	HB	160 SC 4	1450	72	23	0,78	87,8	88,2	87	3,5	3,8	7,3	0,04325	900	75

* Power or motor power-to-size correspondence not according to standard.

□) Temperature rise class F.

3.8

Technical data 400V 50Hz

6 poles - 1000 min⁻¹

IP 55

IC 411

Insulation class F

Temperature rise class B

Extra CE
400V - 50Hz
ErP

Motor for extra CE market only

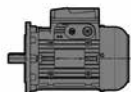

UT.C. 1371

P _N	Motor	n _N	M _N	I _N	cos φ	η			M _S / M _N	M _{max} / M _N	I _S / I _N	J ₀	z ₀	kg
						IEC 60034-2-1								
kW		min ⁻¹	N m	A 400 V		100%	75%	50%				kg m ²	starts/h	
0,75 *	HB 80 C 6	920	7,8	2,3	0,67	70,1	69,7	64,5	2,5	2,7	3,8	0,00314	7100	11,1
0,75	HB 90 S 6	920	7,8	2,2	0,68	72,1	72	67,9	2,4	2,4	3,7	0,00404	7100	13,6
1,1	HB 90 L 6	915	11,5	3,2	0,68	72,9	72	69,3	2,6	2,8	3,9	0,00555	5300	17
1,5 * □	HB 90 LC 6	910	15,7	4,3	0,68	73,8	72,5	70	2,7	2,9	4,3	0,00655	5000	18,5
1,5	HB 100 LA 6	930	15,4	3,9	0,73	75,5	75,4	71,6	2,8	3	4,8	0,00955	3550	21
1,85 *	HB 100 LB 6	930	19	4,9	0,71	76,6	76,2	72,1	3	3,2	5	0,01175	3150	24
2,2	HB 112 M 6	940	22,3	5,4	0,75	78,7	79,7	78,1	2,1	2,5	6,5	0,01482	2800	27
3 * □	HB 112 MC 6	940	30,5	7,2	0,76	79,7	81,2	80,2	2,3	2,7	5,1	0,01882	2500	32
3	HB 132 S 6	960	29,8	7,8	0,68	82,1	82,3	80,2	2,3	3	6	0,02947	2360	42
4	HB 132 M 6	960	39,8	9,7	0,72	83,2	83,7	81,8	2,5	3	6,7	0,03837	1400	49
5,5	HB 132 MB 6	960	55	12,9	0,73	84	84,8	83,4	2,6	3	7	0,04865	1250	58
7,5 * □	HB 132 MC 6	950	75	17,6	0,73	84,7	85	83,8	2,4	2,8	5,7	0,05885	1000	66
7,5 □	HB 160 SC 6	950	75	17,6	0,73	84,7	85	83,8	2,4	2,8	5,7	0,05885	1000	75

* Power or motor power-to-size correspondence not according to standard.

□) Temperature rise class F.

This page is intentionally left blank.

3.9

Motor dimensions

Mounting position
IM B5, IM B5R, IM B5...

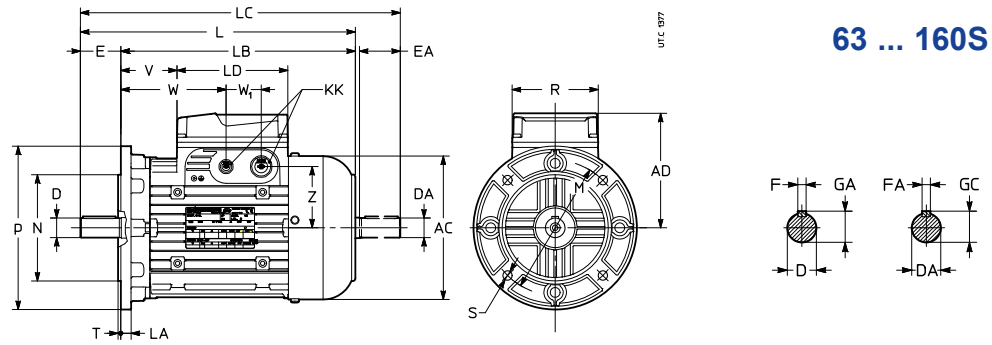

63 ... 160S

Motor size	Shaft end															Flange																	
	AC	AD	L	LB	LC	LD	KK	R	V	W	W ₁	Z	D	1)	E	F	GA	M	N	P	LA	S	T										
	∅						2)						∅		h9			∅	∅	∅	∅												
63	B5R	123	95	226	206	251	103	4×M16	86	46	86	36	45	9	j6	M3	20	3	10,2	100	80	j6	120	8	7	3							
	B5A			229	257									11	j6	M4	23	4	12,5	115	95	j6	140	10	9								
	B5			212	189									240	29	69	11 ³⁾	j6	M4	23 ³⁾	12,5	130	110	j6	160			3,5					
	BX1																																
71	B5B	138	112	258	235	287	2×M16 + 2×M20	66	106	62	11	j6	M4	23	5	16	12,5	100	80	j6	120	8	7	3									
	B5R			265	301													14	j6	M5	30	5	16	115	95	j6	140	10	9				
	B5A			246	216													282	47	87	11 ³⁾	j6	M4	23 ³⁾	4	12,5	130	110	j6	160			3,5
	B5			239	268													14 ³⁾	j6	M5	30 ³⁾	5	16	165	130	j6	200	12	11				
	BX2			246	282																												
	BX5																																
80	B5B	156	121	284	254	321	80	120	71	14	j6	M5	30	6	21,5	165	130	110	j6	160	10	9											
	B5R			294	341												19	j6	M6	40	6	21,5	130	110	j6	160			3,5				
	B5A			273	320												14 ³⁾	j6	M5	30 ³⁾	5	16	165	130	j6	200	12	11					
	B5			263	300																												
90 S ⁴⁾	B5S	176	141	308	278	345	2×M16 + 2×M25	106	60	120	43	75	14	j6	M5	30	6	21,5	130	110	j6	160	10	9									
	B5B			318	365														19	j6	M6	40	6	21,5	165	130	j6	200	12	11			
	B5R			297	344														24	j6	M8	50	8	27									
	B5			307	364																												
90 L	B5S			338	308	375			90	150			14	j6	M5	30	5	16	130	110	j6	160	10	9									
	B5B			348	395														19	j6	M6	40	6	21,5	165	130	j6	200	12	11			
	B5R			327	374														24	j6	M8	50	8	27									
	B5			337	394																												
100	B5C	194	151	377	337	425			109	169			86	19	j6	M6	40	6	21,5	130	110	j6	160	10	9								
	B5S			387	445															24	j6	M8	50	8	27	165	130	j6	200	12	11		
	B5R			397	465															28	j6	M10	60		31	215	180	j6	250	14	14	4	
	B5A			370	310															438	82	142											
112	B5S	218	163	402	362	451			126	186			98	19	j6	M6	40	6	21,5	165	130	j6	200	12	11	3,5							
	B5R			412	471															24	j6	M8	50	8	27								
	B5A			422	491															28	j6	M10	60		31	215	180	j6	250	14	14	4	
	B5			396	336															465	100	160											
132 S, M ⁵⁾	B5S	257	194	470	420	529	2×M16 + 2×M32	148	113	201	55	109	24	j6	M8	50		27	165	130	j6	200	12	11	3,5								
	B5B			480	549														28	j6	M10	60		31	215	180	j6	250	14	14	4		
	B5R			500	589														38	k6	M12	80	10	41	265	230	j6	300					
	B5A			465	385														554	78	166												
132 MA ⁷⁾ ... MC	B5S			530	480	589			173	261			24	j6	M8	50	8	27	165	130	j6	200	12	11	3,5								
	B5B			540	609														28	j6	M10	60		31	215	180	j6	250	14	14	4		
	B5R			560	649														38	k6	M12	80	10	41	265	230	j6	300					
	B5A			525	445														614	138	226												
160 S	B5			574	464	663							42	k6	M16 ⁶⁾	110 ⁶⁾	12 ⁶⁾	45 ⁶⁾	300	250	h6	350	15	18	5								

1) Tapped butt-end hole.

2) Prearranged for cable entry knockout openings on both sides (two openings on each side).

3) Shaft end not according to standard.

4) For motor HB3 90S 2, HB3 90S 4 dimensions are the ones as size 90L.

5) For motor HB3 132SB 2, HB3 132SC 2, HB3 132 S 4, HB3 132M 4 and HB3 132M 6 dimensions are the ones as size 132 MA ... MC.

6) The dimensions of second shaft are the same as size 132.

7) For motor HB 132MA 2 dimensions are the ones as size 132S.

Mounting position
IM B14, IM B14R

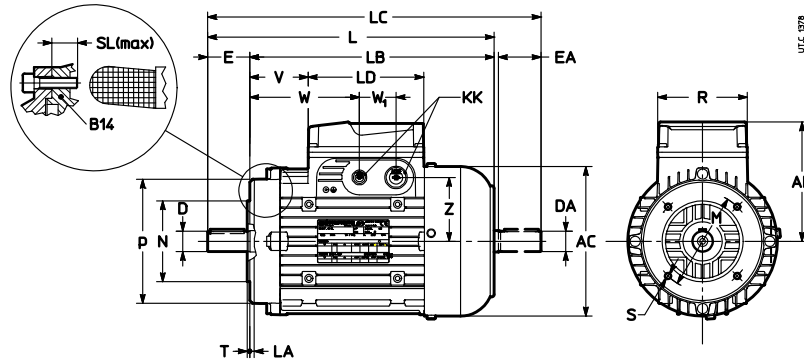

63 ... 1322

Motor size	AC	AD	L	LB	LC	LD	KK	R	V	W	W ₁	Z	Shaft end					Flange										
													D DA	¹⁾ E EA	F FA	GA GC	M	N	P	LA	S	SL	T					
63	B14	123	95	212	189	240	103	4×M16	86	29	69	36	45	11	j6	M4	23	4	12,5	75	60	j6	90	8	M5	10	2,5	
71	B14R B14	138	112	239	216	268	103	2×M16 + 2×M20	86	47	87	36	62	14	j6	M5	30	5	16	85	70	j6	105	8	M6	10	2,5	
80	B14R B14	156	121	263	233	300				59	99		71	19	j6	M6	40	6	21,5	100	80	j6	120	8	M6		3	
90 S⁸⁾	B14	176	141	307	257	364				136	2×M16 + 2×M25		106	39	99	43	75	24	j6	M8	50	8	27	115	95		j6	140
90 L	B14			337	287	394				69	129																	
100	B14	194	151	370	310	438				82	142		86	28	j6	M10	60	8	31	130	110	j6	160	10	M8	13	3,5	
112	B14	218	163	396	336	465				100	160		98															
132 S, M⁹⁾	B14	257	194	465	385	554	190	2×M16 + 2×M32	148	78	166	55	153	38	k6	M12	80	10	41	165	130	j6	200	8	M10	18	3,5	
132 MA¹⁰⁾... MCB14				525	445	614				138	226																	

1) Tapped butt-end hole.

2) Prearranged for cable entry knockout openings on both sides (two openings on each side).

8) For motor **HB3 90S 2** and **HB3 90S 4** dimensions are the ones as size 90L.

9) For motor **HB3 132SB 2**, **HB3 132SC 2**, **HB3 132 S 4**, **HB3 132M 4** and **HB3 132M 6** dimensions are the ones as size 132 MA ... MC.

10) For motor **HB 132MA 2** dimensions are the ones as size 132S.

Mounting position
IM B3

63 ... 160S

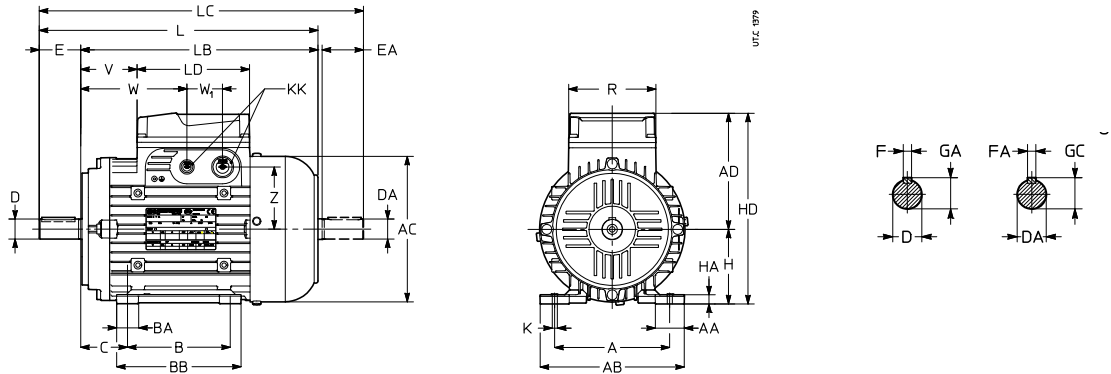

Motor size	AC	AD	L	LB	LC	LD	KK	Shaft end							Feet																				
								R	V	W	W ₁	Y	Z	D	1)	E	F	GA	A	AB	B	C	BB	BA	AA	K	HA	H ⁷⁾	HD						
	∅						2)	R ₁					∅		EA	FA	h ₉																		
63	B3	123	95	212	189	240	103	4×M16	86	29	69	36	-	45	11	j6	M4	23	4	12,5	100	120	80	40	100	21	27	7	9	63	158				
71	B3	138	112	246	216	282		2×M16 + 2×M20	-	47	87			62	14	j6	M5	30	5	16	112	138	90	45	110	22	28		10	71	183				
80	B3	156	121	273	233	320				59	99			71	19	j6	M6	40	6	21,5	125	152	100	50	125	26		9	80	201					
90 S⁹⁾	B3	176	141	307	257	364	136	2×M16 + 2×M20	106	39	99	43		75	24	j6	M8	50	8	27	140	174		56			35	11	90	230					
90 L	B3			337	287	394				69	129												125	150											
100	B3	194	151	370	310	438				82	142			86	28	j6	M10	60	8	31	160	196	140	63	185	40	37	12	12	100	251				
112	B3	218	163	396	336	465				100	160			98							190	226		70			50	15	112	275					
132 S, M⁹⁾	B3	257	194	465	385	554	190	2×M16 + 2×M32	148	78	166	55	-	109	38	k6	M12	80	10	41	216	257	140 ³⁾	89	210	42	52	14	17	132	326				
132 MA¹⁰⁾ ...MC B3				525	445	614				138	226												178 ³⁾												
160 S	B3			574 ⁴⁾	464	663 ⁴⁾				157	245			42	k6	M16 ⁴⁾	110 ⁴⁾	12 ⁴⁾	45 ⁴⁾	254	294	210	108	246	45			20	160	354					

1) Tapped butt-end hole.

2) Prearranged for cable entry knockout openings on both sides (two openings on each side).

3) Shaft end not according to standard.

4) For motor **HB3 90S 2**, **HB3 90S 4** dimensions are the ones as size 90L.

5) For motor **HB3 132SB 2**, **HB3 132SC 2**, **HB3 132 S 4**, **HB3 132M 4** and **HB3 132M 6** dimensions are the ones as size 132 MA ... MC.

6) The dimensions of second shaft are the same as size 132.

7) For motor **HB 132MA 2** dimensions are the ones as size 132S.

Non-standard designs and accessories

Ref.	Description	Non-standard design code
(1)	Non-standard motor supply	-
(2)	Driving shaft axially fastened	,AX
(3)	Insulation class H	,H
(7)	Design for low temperatures (-30 °C) ¹	,BT
(8)	Condensate drain holes	,CD
(9)	Additional winding impregnation	,SP
(13)	Anti-condensation heater	,S
(14)	Terminal box on one side for IM B3 and derivatives (90 ... 160S)	,P
(16)	Second shaft end	,AA
(17)	Axial independent cooling fan	,V ...
(18)	Axial independent cooling fan and encoder	,V ... ,E...
(19)	Thermistor type thermal probes (PTC)	,T15
(20)	Bi-metal type thermal probes	,B15
(21)	Drip-proof cover	,PP
(31)	Motor without fan for fans	,SV
(32)	Motor without fan by natural convection (63 ... 112)	,CN
(33)	Design for high temperatures	,AT
(35)	Light alloy fan	,VL
(36)	Encoder	,E1 ... ,E5
(42)	Motor certified to UL	,UL
(62)	Motor pre-arranged for encoder	,PE
(63)	Axial independent cooling fan and prearranged for encoder	,V...,PE
(64)	IP 66 protection	,IP 66

(1) Non-standard motor supply

The first two columns show the possible types of supply.

Supply of independent cooling fan is **co-ordinated** with motor winding voltage as stated in the table.

Motor wound and stated for		Operational details		
V	Hz	HB	HB2	HB3
Δ 220 Y380	50	○	●	●
Δ 230 Y400	50	●	●	●
Δ 265 Y460	60	●	●	●
Δ 277 Y480	60	○	●	●
Δ 240 Y415	50	○	●	●
YY 230 Y460	60	○	○	○
Δ 400	50	○	○	○
Δ 480	60	○	○	○
Δ 255 Y440	60	○	○	○
Δ 415	50	○	○	○
Δ 440	60	○	○	○
Δ 460	60	○	○	○
Δ 220 Y380	60	○	○	○
Δ 380	60	○	○	○
Δ 290 Y500	50	○	○	○
Δ 346 Y600	60	○	○	○

● standard ○ on request — not foreseen

For different voltage values consult us.

Designation: following the instructions at ch. 3.2, state **voltage** and **frequency** (in the first table columns).

(2) Driving shaft axially fastened

Driving shaft axially fastened on rear (sizes 63 ... 160S) or front endshield through circlip on endshield and on shaft.

This design is **necessary** in case of axial alternating stresses (e.g.

helical pinion with **alternating load and/or run**, frequent on-load starts and/or with great inertiae) causing axial slidings on driving shaft and impacts on bearings.

Non-standard design code for the **designation: ,AX**

(3) Insulation class H

Insulation materials in class H with permissible temperature rise in class H.

Non-standard design code for the **designation: ,H**

(7) Design for low temperatures (-30 °C)

Standard motors can operate at ambient temperature down to -15 °C.

For ambient temperature down to -30 °C, sizes 63 ... 160S: special bearings, light alloy fan (in addition cable glands and metal plugs if foreseen in the conditions of supply).

If there are dangers of condensate, it is advisable to require, also the «Design for protection IP66» (64) and, if necessary the design «Condensate drain holes» (8) and «Anti-condensation heater» (13).

With designs (17), (18), (36) and (63), consult us.







Non-standard design code for the **designation: ,BT**

(8) Condensate drain holes

It is advisable for motors operating in particularly damp environments and/or with wide variation in the temperature and/or at low temperature. In motor designation state in «MOUNTING POSITION» the designation of the real application mounting position, determining the hole position.

Motors are supplied with closed holes.

Non-standard design code for the **designation: ,CD**

Mounting position						
IM						
B3	IM 1001	IM 1011	IM 1031	IM 1051	IM 1061	IM 1071
B5	IM 3001	IM 3011	IM 3031	IM 3051	IM 3061	IM 3071
B14	IM 3601	IM 3611	IM 3631	IM 3651	IM 3661	IM 3671
B3-B5	IM 2001	IM 2011	IM 2031	IM 2051	IM 2061	IM 2071
B3-B14	IM 2101	IM 2111	IM 2131	IM 2161	IM 2161	IM 2171
B3 ,AA	IM 1002	IM 1012	IM 1032	IM 1052	IM 1062	IM 1072
B5 ,AA	IM 3002	IM 3012	IM 3032	IM 3052	IM 3062	IM 3072
B14 ,AA	IM 3602	IM 3612	IM 3632	IM 3652	IM 3662	IM 3672

(9) Additional winding impregnation

It consists of a second impregnation cycle after stator windings assembly standard supplied with design (64).

Useful where it is necessary to have an additional protection (of the windings) against electrical stress (voltage peaks due to rapid commutations or to «low quality» inverters with high voltage gradients) or mechanical agents (mechanical or electromagnetic vibrations: e.g. from inverter). See also ch. 2.9 «Voltage peaks (U_{max}), voltage gradients (dU/dt), cable length».

Non-standard design code for the **designation: ,SP**

(13) Anti-condensation heater

It is advisable for motors operating in particularly damp environments and/or with wide variation in the temperature and/or at low temperature; single-phase supply 230 V a.c. $\pm 10\%$ 50 or 60 Hz (other voltage on request); power absorbed: 15 W for sizes 63 and 71, 25 W for sizes 80 ... 100, 50 W for sizes 112 ... 160S. Heater must not be connected during the running.

Cables connected to fixed or loose terminal block inside terminal box.

Non-standard design code for the **designation: ,S**

(14) Terminal box on one side for IM B3 and derivatives (sizes 90 ... 160S)

Terminal box in position P1 or P2 as scheme on the left.

Non-standard design code for the **designation:**

,P... (additional code 1 or 2 according to scheme beside).

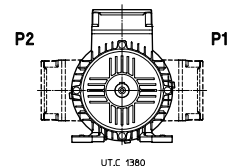

(16) Second shaft end

For dimensions see ch. 3.8; radial loads are not permissible; not possible in case of designs (17), (18), (36), (62) and (63).

Non-standard design code for the **designation: ,AA**

(17) Axial independent cooling fan

Cooling provided by axial independent cooling fan, **compact** type for sizes 63 ... 160S, for variable speed drives (motor can absorb nominal current for all speed range, in continuous duty cycle and without overheating) with inverter and/or for heavy starting cycles (for Z_0 increases consult us).

LB dimensions **increase** (see ch. 3.8) by ΔLB quantity as per following table.

Specifications of independent cooling fan:

- 2 poles motor for sizes 63 ... 160S;
- **IP 54** protection for sizes 63 ... 160S;
- supply terminals on proper auxiliary terminal block in the motor terminal box for sizes 63 ... 160S;
- other data according to following table.

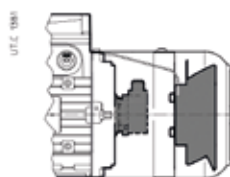

63 ... 160S

Motor size wound and stated for			Independent cooling									
Motor size	V	Hz	Independent cooling fan name plate				kg	Code	Type	ΔLB		
			V	Hz	W	A						
63 ... 80	Δ220 Y380	50	230	50/60	19/18	0,12/0,11	0,4	,VA	Single phase	78 (Size 63)	63 (Size 71)	65 (Size 80)
	Δ230 Y400	50										
	Δ265 Y460	60										
	Δ277 Y480	60										
	Δ240 Y415	50										
	YY230 Y460	60										
	Δ400	50										
	Δ480	60										
	Δ255 Y440	60										
	Δ415	50										
	Δ440	60										
	Δ460	60										
	Δ220 Y380	60										
	Δ380	60										
	Δ290 Y500	50										
Δ346 Y600	60											
90	Δ220 Y380	50	230	50/60	45/39	0,31/0,25	0,9	,VA	Single phase	82		
	Δ230 Y400	50										
	Δ265 Y460	60										
	Δ277 Y480	60										
	Δ240 Y415	50										
	YY230 Y460	60										
	Δ400	50										
	Δ480	60										
	Δ255 Y440	60										
	Δ415	50										
	Δ440	60										
	Δ460	60										
	Δ220 Y380	60										
	Δ380	60										
	Δ290 Y500	50										
Δ346 Y600	60											
100,112	Δ220 Y380	50	Y380	50	40	0,12			Three phase	89 (Size 100)	81 (Size 112)	
	Δ230 Y400	50	Y400	50	45	0,13						
	Δ265 Y460	60	Y460	60	45	0,13						
	Δ277 Y480	60	Y480	60	50	0,15						
	Δ240 Y415	50	Y415	50	45	0,13						
	YY230 Y460	60	Y460	60	45	0,13						
	Δ400	50	Y400	50	45	0,13						
	Δ480	60	Y480	60	50	0,15						
	Δ255 Y440	60	Y440	60	43	0,12						
	Δ415	50	Y415	50	45	0,13						
	Δ440	60	Y440	60	43	0,12						
	Δ460	60	Y460	60	45	0,13						
	Δ220 Y380	60	Y380	60	38	0,11						
	Δ380	60	Y380	60	38	0,11						
	Δ290 Y500	50	Y500	50	45	0,1						
132,160S	Δ220 Y380	50	Y380	50	50	0,13	1,7	,VD	Three phase	88		
	Δ230 Y400	50	Y400	50	53	0,15						
	Δ265 Y460	60	Y460	60	65	0,14						
	Δ277 Y480	60	Y480	60	70	0,15						
	Δ240 Y415	50	Y415	50	51	0,16						
	YY230 Y460	60	Y460	60	65	0,14						
	Δ400	50	Y400	50	53	0,15						
	Δ480	60	Y480	60	70	0,15						
	Δ255 Y440	60	Y440	60	60	0,14						
	Δ415	50	Y415	50	51	0,16						
	Δ440	60	Y440	60	60	0,14						
	Δ460	60	Y460	60	65	0,14						
	Δ220 Y380	60	Y380	60	56	0,12						
	Δ380	60	Y380	60	56	0,12						
	Δ290 Y500	50	Y500	50	53	0,12						
								,VF				

Non-standard design code for the designation: ,VA ,VD ,VF.
IC 416 is stated on name plate

(18) Axial independent cooling fan and encoder

Independently cooled motor equipped with hollow shaft **encoder** with elastic fastening.

For specifications and designation code relevant to the independent cooling fan and the encoder see design (17) and design (36), respectively.

Motor overall dimensions as «Axial independent cooling fan» design (17).

Non-standard design code for the **designation: ,V ... ,E...**

IC 416 is stated on name plate

(19) Thermistor type thermal probes (PTC)

Three thermistors wired in series (to DIN 44081/44082), inserted in the windings, for connection to a suitable contact breaker device. A sharp variation in resistance occurs when (delay 10 ÷ 30 s) the temperature of the windings reaches the setting temperature of **150 °C** (T15).

With designs «Insulation class H» (3) and/or «Design for high temperature» (33) if required, thermistors with setting temperature of 170 °C (T17) are supplied.

Terminals connected to a loose or fixed terminal block inside the terminal box.

Non-standard design code for the **designation: ,T15**

(20) Bi-metal type thermal probes

Three bi-metal probes wired in series with usually closed contact inserted in the windings. Nominal current 1,6 A, nominal voltage 250 V a.c. The contact opens when (delay 20 ÷ 60 s) the temperature of the windings reaches the setting temperature of **150 °C** (B15).

With designs «Insulation class H» (3) and «Design for high temperature» (33) if required, bi-metal probes with setting temperature of 170 °C (B17) are supplied.

Terminals connected to a loose or fixed terminal block inside the terminal box.

Non-standard design code for the **designation: ,B15**

(21) Drip-proof cover

Necessary design for outdoor applications or when water sprays are present, in mounting position with downwards vertical shaft (IM V5, IM V1, IM V18).

LB dimension (see. ch. 3.8) increases by ΔLB stated in table:

Non-standard design code for the **designation: ,PP**

Motor size	ΔLB [mm]
63 ... 160S	25

(31) Motor without fan for fans

Motor without fan, with non-drive end completely closed endshield having the same electric specifications and power of the standard motor (as stated on ch. 3.5 ... 3.7).

Design for fans or for applications where cooling is ensured by the external environment (in nameplate IC 418). Design suitable also when duty cycle is periodic intermittent and of such short duration that they do not require any cooling (in nameplate IC 410 and S2 duty cycle, 5 min); if necessary, consult us.

LB dimension (see ch. 3.8) **decreases** by ΔLB quantity as per table beside.

Not possible with design «Drive shaft axially fastened» (2), and Premium Efficiency (IE3) EISA motors with design (42).

Non-standard design code for the **designation: ,SV**

IC 418 or 410 is stated on name plate.

Motor size	ΔLB [mm]
63	33
71	41
80	43
90	46
100	53
112	58
132	69

(32) Motor without fan with external cooling by natural convection (63 ... 132)

Motor without fan, with external cooling by natural convection and non-drive end completely closed endshield. Available both for continuous duty S1 and for intermittent duty S3 70%. Electric winding and electric specifications differ from the standard motor and power is derated: as a guide, coefficients and power values (when available) are stated in the table.

Design normally required in textile industry.

Motor dimensions as «Motor without fan for fans» (31) design.

Not possible with designs:

«Drive shaft axially fastened» (2),

«Premium Efficiency (IE3) EISA motors».

«Motors certified to UL» (42) are available only with 4 poles and duty S3 70%.

Non-standard design code for the **designation**: ,CN

IC 410 is stated on name plate.

Poli	Motor size (HB)	P_N (S1) [kW]	P_N (S3 70%) [kW]
2	63 ... 132	$\sim 0,2 * P_N^{1)}$	$\sim 0,3 * P_N^{1)}$
4	63 A	$\sim 0,3 * P_N^{1)}$	0,09
	63 B		0,12
	63 C		0,18
	71 B		0,18
	71 C		0,25
	71 D		0,37
	80 B		0,37
	80 C		0,55
	90 S		0,55
	90 L		0,75
	90 LC		1,1
	100 LA		1,1
	100 LB		1,5
	112 M		1,85
	112 MC		2,2
	132 S		2,2
132 M	3		
132 MB	4		
132 MC	5,5		
6	63 ... 132	$\sim 0,5 * P_N^{1)}$	$\sim 0,7 * P_N^{1)}$

1) Consult us for the verification of each single case.

(33) Design for high temperatures

For ambient temperature $60^{\circ}\text{C} < T^{\circ}\text{C} \leq 90^{\circ}\text{C}$ (including non-standard design ,AT40): insulation class H, fluoro rubber seal rings, non-standard bearings, (for AT70 and AT90), metallic fan, cable gland and metallic terminal box plugs (if foreseen).

Motor power values stated on ch. 3.5 ... 3.7 can be derated according to the following table:

Poles	Motor size	Ambient temperature 40 °C		Ambient temperature 70 °C		Ambient temperature 90 °C	
		designation:		designation:		designation:	
		,AT40		,AT70		,AT90	
		(HB, HB2, HB3 see ch. 3.5 ... 3.7)		(HB)		(HB)	
		P_N [kW]	P_N [hp]	P_N [kW]	P_N [kW]	P_N [kW]	P_N [kW]
		Nominal		Available		Available	
2	63 A	0,18	0,25	0,18	0,12	0,12	0,09
	63 B	0,25	0,33	0,25	0,18	0,18	0,12
	63 C	0,37	0,5	0,37	0,25	0,25	0,18
	71 A	0,37	0,5	0,37	-	-	-
	71 B	0,55	0,75	0,55	-	-	0,25
	71 C	0,75	1	0,75	0,37	-	-
	71 D	-	-	-	-	0,37	-
	80 A	0,75	1	0,75	0,55	0,37	0,37
	80 B	1,1	1,5	1,1	0,75	0,55	0,55
	80 C	1,5	2	-	-	-	-
	80 D	1,85	2,4	-	-	-	-
	90 S	1,5	2	1,1	-	0,75	0,75
	90 SB	1,85	2,4	-	-	1,1	1,1
	90 LA	2,2	3	1,5	-	1,5	1,5
	90 LB	3	4	1,85	-	-	-
	100 LA	3	4	-	-	-	-
	100 LB	4	5,4	2,2	-	1,85	1,85
	112 M	4	5,4	3	-	-	-
	112 MB	5,5	7,5	4	-	2,2	2,2
	112 MC	7,5	10	-	-	3	3
132 S	5,5	7,5	-	-	4	4	
132 SB	7,5	10	5,5	-	5,5	5,5	
132 SC	9,2	12,4	-	-	-	-	
132 MA	11	15	7,5	-	7,5	7,5	
132 MB	15	20	9,2	-	9,2	9,2	
160 SA	11	15	7,5	-	7,5	7,5	
160 SB	15	20	9,2	-	9,2	9,2	
4	63 A	0,12	0,16	0,12	0,09	0,09	0,06
	63 B	0,18	0,25	0,18	0,12	0,12	0,09
	63 C	0,25	0,33	0,25	0,15	0,15	0,12
	71 A	0,25	0,33	0,25	-	-	-
	71 B	0,37	0,5	-	-	-	0,15
	71 C	0,55	0,75	0,37	-	-	0,18
	71 D	0,75	1	-	-	-	-
	80 A	0,55	0,75	0,55	0,25	0,25	0,25
	80 B	0,75	1	0,75	0,37	0,37	0,37
	80 C	1,1	1,5	-	-	-	-
	90 S	1,1	1,5	-	0,55	0,55	0,55
	90 L	1,5	2	1,1	-	-	-
	90 LB	1,85	2,4	1,5	-	0,75	0,75
	90 LC	2,2	3	1,85	-	-	-
	100 LA	2,2	3	-	-	-	-
	100 LB	3	4	2,2	-	1,85	1,85
	112 MA	3	4	-	-	-	-
	112 M	4	5,4	3	-	2,2	2,2
	112 MC	5,5	7,5	-	-	3	3
	132 S	5,5	7,5	4	-	4	4
132 M	7,5	10	5,5	-	5,5	5,5	
132 MB	9,2	12,4	7,5	-	7,5	7,5	
132 MC	11	15	9,2	-	9,2	9,2	
160 SC	11	15	9,2	-	9,2	9,2	
6	63 A	0,09	0,12	0,09	0,06	0,06	0,06
	63 B	0,12	0,16	0,12	0,09	0,09	0,09
	63 C	0,15	0,20	0,15	0,12	0,12	0,12
	71 A	0,18	0,25	0,18	0,15	0,15	0,15
	71 B	0,25	0,33	0,25	0,25	0,25	0,18
	71 C	0,37	0,5	-	-	-	-
	80 A	0,37	0,5	0,37	0,25	0,25	0,25
	80 B	0,55	0,75	-	-	-	0,37
	80 C	0,75	1	0,55	-	-	-
	90 S	0,75	1	-	0,55	0,55	0,55
	90 L	1,1	1,5	0,75	-	-	-
	90 LC	1,5	2	-	0,75	0,75	0,75
	100 LA (ErP IE3-60 Hz)	0,75	1	-	-	-	-
	100 LA	1,5	2	-	-	0,75	0,75
	100 LB	1,85	2,4	1,1	-	1,1	1,1
	112 M (ErP IE3-60 Hz)	1,1	1,5	-	-	-	-
	112 MB (ErP IE3-60 Hz)	1,5	2	-	-	-	-
	112 M	2,2	3	1,5	-	1,5	1,5
	112 MC	3	4	1,85	-	1,85	1,85
	132 S (ErP IE3-60 Hz)	2,2	3	-	-	-	-
132 S	3	4	2,2	-	2,2	2,2	
132 M (ErP IE3-60 Hz)	3	4	-	-	-	-	
132 M	4	5,4	3	-	3	3	
132 MB (ErP IE3-60 Hz)	4	5,4	-	-	-	-	
132 MB	5,5	7,5	4	-	4	4	
132 MC	7,5	10	5,5	-	5,5	5,5	
160 SC	7,5	10	5,5	-	5,5	5,5	

Poles	Motor size	Ambient temperature 40 °C		Ambient temperature 70 °C		Ambient temperature 90 °C	
		designation:		designation:		designation:	
		,AT40		,AT70		,AT90	
	(HB, HB2, HB3 see ch. 3.5 ... 3.7)	(HB)		(HB)		(HB)	
		P_N [kW]	P_N [hp]	P_N [kW]	P_N [kW]	P_N [kW]	P_N [kW]
		Nominal		Available	Available		Available
4 Premium efficiency	90 S	-	1	-	-	-	-
	90 L	-	1,5	-	-	-	-
	90 LB	-	2	-	-	-	-
	112 MA	-	3	-	-	-	-
	112 M	-	4	-	-	-	-
	112 MB	-	5,4	-	-	-	-
	132 M	-	7,5	-	-	-	-
	132 MB	-	10	-	-	-	-
6 Premium efficiency	100 LA	-	1	-	-	-	-
	112 M	-	1,5	-	-	-	-
	112 MB	-	2	-	-	-	-
	132 S	-	3	-	-	-	-
	132 M	-	4	-	-	-	-
	132 MB	-	5,4	-	-	-	-

This design is available for nominal power for ambient temperature 40° C (**,AT 40°**).

Designs ,AT 70° C ,AT 90° C not possible for:

- HB2 motors (IE2 ErP);
- HB3 motors (IE3 ErP);
- Premium Efficiency motors (IE3 EISA);
- Extra CE motor;
- Designs (17), (18), (36), (63).

Following table states the designs available according to ambient temperature and motor power.

For temperatures 70° C and 90° C power can be derated and on nameplate H insulation class and required ambient temperature are stated (40° C, 70° C or 90° C).

Define the following data before selecting:

- Ambient temperature;
- Motor power;
- Motor size and pole number;
- Select motor type for 40°C see ch. 3.4 ... 3.6 for 70° C or 90° C only HB

E.g.: $T_{amb} = 90^{\circ}C$, $P_N = 1,1$ kW, Poles=4 **HB 90L 4**

Non-standard design code for the **designation: ,AT...**

(35) Light alloy fan

Motor with light alloy fan (aluminum) for environments where it is not advisable to use the standard plastic fan.

Non-standard design code for the **designation: ,VL**

(36) Encoder

Motor (driving shaft **axially fastened** as standard) equipped with incremental hollow shaft encoder and elastic fastening with the following features stated in the table (free connection wirings for the use of connectors installed by the Buyer). For different and/or additional specifications consult us.

LB dimension (see ch. 3.8) **increases** by ΔLB quantity given in the table.

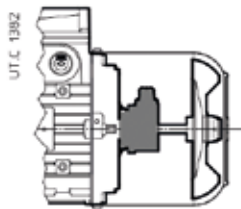

63 ... 160S

Motor size	ΔLB [mm]
63	52
71	51
80	54
90	51
100	56
112	52
132, 160S	54

Output signal ¹⁾	RS 422 LD TTL	RS 422 TTL	Push - Pull HTL LD HTL	sin / cos	
Supply voltage U_B	5 V d.c. \pm 5%		10 \div 30 V d.c.		5 V d.c. \pm 5% 10 \div 30 V d.c.
Maximum current consumption (without load) I_N	90 mA		100 mA		110 mA
Channels	A+, A-, B+, B-, 0+, 0-				
Output amplitude per track	$U_l \leq 0,5 V_{dc}; U_h \geq 2,5 V_{dc}$		$U_l \leq 0,5 V_{dc}; U_h \geq U_B - 1 V_{dc}$		1 $V_{pp} \pm 20\%$ (channel A, B) 0,1 \div 1,2 V (channel 0)
Maximum output current per track I_{out}	± 20 mA		± 30 mA		-
Maximum pulse frequency f_{max}	100 \div 300 kHz ^{2) 3)}				-
Frequency -3 dB	-				≥ 180 kHz
No. pulse per revolution	1024 ⁴⁾				
Vibration resistance (DIN-IEC 68-2-6)	≤ 100 m/s ² , 10 ... 2000 Hz				
Shock resistance (DIN-IEC 68-2-27)	$\leq 1000 \div 2500$ m/s ² , 6 ms ²⁾			≤ 2000 m/s ² , 6 ms	
Maximum speed	6 000 min ⁻¹				
Ambient temperature	$[-160S]$ -40 °C \div 100 °C	-30 °C \div 85 °C	$[-160S]$ -40 °C \div 100 °C	-25 °C \div 85 °C	
Protection degree (EN 60 529)	IP65				
Connections	free cables ⁸⁾ L = 1000 mm for use of connector installed by the user				
Encoder cable cross-sections	2 \times 0,22+6 \times 0,14 [mm ²]	10 \times 0,14 [mm ²]	2 \times 0,22+6 \times 0,14 [mm ²]	8 \times 0,22 [mm ²]	8 \times 0,22 [mm ²]
Code for designation	,E1	,E2	,E3	,E4	,E5

1) Other electronic configurations available on request; consult us.

2) Variable depending on the model.

3) Parameter to be checked depending on the combination max motor speed/pulse per revolution required.

4) Other pulse rates available on request (max 5000 ppr).

8) On request: different cable lengths, output with connector or with connector and cable; consult us.

Non-standard design code for the **designation**: ,E1 ... ,E5 (see table).

(42) Motor certified to UL

Motor sizes (≤ 750 V, 50/60 Hz) both to UL1004-1 and CAN/CSA 23.2 No.100-14, for USA and Canada markets respectively, and electrically complying with NEMA Standard Publication MG 1-12 2009.

The main variations of this product are:

- approved UL class F insulation winding system;
- approved UL terminal block terminal assignment according to NEMA;
- cooling fan made of aluminium or certified thermoplastic material;
- certified and marked cables;
- verification and adjustment of air distances toward ground and between live parts;
- name plate with logo , showing only the data relating to the supply required in the order.
- for motor with $P_N \geq 1$ hp (motor with EISA Premium Efficiency class excluded) are available with intermittent duty cycle S3 70%.

All other non-standard designs are possible, excluding design (31) and (32), (32) and (33 (with $T_{amb.}$ 70° C and 90° C)) and Extra CE motors.

For design (32) see the combinations available in the corresponding paragraph.

Standard for 230YY 460Y V, 60 Hz motor supply and for motor with efficiency EISA Premium Efficiency class.

Non-standard design code for the **designation**: ,UL.

(62) Motor prearranged for encoder

Motor (motor shaft axially fastened as standard) prearranged for encoder with following features:

- anti-rotation center distance \varnothing 63 mm;
- flexible anti-rotation bracket with 1 or 2 holes/slots at 180° suitable for screw passage M3;
- max encoder height 48 mm;
- motor shaft \varnothing 10 h6 mm.

Motor dimensions as design (36).

Non-standard design code for the **designation**: ,PE

(63) Axial independent cooling fan and prearranged for encoder

Independently cooled motor (motor shaft axially fastened as standard) prearranged for encoder with following features:

- anti-rotation center distance \varnothing 63 mm;
- flexible anti-rotation bracket with 1 or 2 holes/slots at 180° suitable for screw passage M3;
- max encoder height 48 mm;
- motor shaft \varnothing 10 h6 mm and length 35 mm.

For specifications and independent cooling fan designation code see design (17).

Motor overall dimensions as «Axial independent cooling fan» (17).

Non-standard design code for the **designation**: ,V... ,PE

IC 416 is stated on name plate

(64) IP 66 Protection

Advised for installation in environments as stated in the table below, including relevant limitations.

Environment type	Non-standard designs				
	(17)	(18)	(36)	(62)	(63)
Outdoor					
In damp environment					
In case of condensate			○	●	○
In sea or aggressive environment	○	○		●	○
In case of direct bolts/ water splash					
In dusty environment			●		

- Possible
- Consult us

Including design «Additional winding impregnation» (9) and anti-rust painting of rotor and shaft, adhesive on housing and endshield mating surfaces (to be re-adjusted in case of motor disassembling).

In these cases it is advised to require the following designs as well:

- «Condensate drain holes» (8)
- «Anti-condensation heaters» (13)

Non-standard design code for **designation**: ,IP 66

Miscellaneous

- Asynchronous three-phase two-speed motors.
- Asynchronous single-phase motors with running capacitor always switched on, running + starting and electronic disjuncter, balanced winding.
- Special paints or completely unpainted motor.
- Motor balancing according to reduced vibration degree (B) to CEI EN 60034-13.
- Motors with integral feet and flange (IM B35, IM B34 and relevant vertical mounting positions).
- Fan cover for textile industry (63 ... 132).
- Power connector.
- Sensorized drive end bearing (32, 48 or 64 pulses per revolution) for the measurement of angle and/or rotation speed (sizes 63 ... 100); for specifications and wiring schemes consult us.
- Pt 100 temperature probe.
- Encoder for high temperatures.
- Designs with supply cable.
- Design for oil seal (e.g. coupled with mechanical variator).
- Motor certified to ATEX II categories 3 GD and (sizes 63 ... 160S) 2D.
- Flywheel.
- Motor for roller tables HRN, HRS.
- Motor for corrosive and aseptic environments; INOX motor.

3.11

Name plate

MOT.(1)~ (9) (14) (15)	(2) (3) (4) (5) (10)	IP (6) kg (11)	AMB.(7) I.CL.(12)	IC (8) S (13)	V~/Hz A #/## V=		
DE/NDE (16)		(17)		(18)			
(19) V (19)	% (21)	Hz (22)	% (23)	A (24)	kW (25)	min ⁻¹ (26)	cos φ (27)
(20)							
(28)							
(29)							

UTC 2298

MOT.(1)~N.(9)	(10)	IP (6) kg (11)	AMB.(7) I.CL.(12)S (13)	IC (8)	V~/Hz A #/## V=		
DE/NDE (16)		(17)		(18)			
(19) V (19)	Hz (22)	A (24)	HP (25)	RPM (26)	PF (27)	NOM. EFF (28)	
(20)							
NEMA MG1-12 SF (36) DESIGN (29) CODE (29)							
ENERGY Verified for energy efficiency in accordance with US DOE 10CFR431, dated September 22, 2015							
Verified for energy efficiency in accordance with CSA C390-10, dated March 2010, reaffirmed 2015							
CC131B E304505							

UTC 2162A

NEMA YY230 Y460V, 60Hz

- (1) Number of phases
- (2) Motor type
- (3) Size
- (4) Number of poles
- (5) Designation of mounting position
- (6) Protection IP ...
- (7) Maximum ambient temperature
- (8) Code IC
- (9) Production number
- (10) Two months and year of manufacturing end serial number
- (11) Motor mass
- (12) Insulation class I.CL...
- (13) Duty cycle S...
- (14) Motor code
- (15) Customer code¹⁾
- (16) Bearings
- (17) Note 1
- (18) Note 2
- (19) Connection of the phases
- (20) Nominal voltage
- (21) Voltage tolerance
- (22) Nominal frequency
- (23) Frequency tolerance
- (24) Nominal current
- (25) Nominal power
- (26) Nominal speed
- (27) Nominal power factor
- (28) Nominal efficiency IEC 60034-2-1
- (29) Design - code
- (36) Service factor

1) On request

MOT. 3 ~ HB3 90L 4 B3	IP 55	AMB. 40°C	IC 411	V~/Hz A #/## V=			
2380729 02/21 7622429	kg 19	I.CL. F	S 1				
R000154943	h		g				
Δ V Y	%	Hz	%	A	kW	min ⁻¹	cos φ
220/380		50		5.9/3.4	1.5	1415	0.81
230/400		50		5.7/3.3	1.5	1430	0.78
240/415		50		5.7/3.3	1.5	1430	0.76
265/460		60		5.0/2.9	1.5 SF1.15	1740	0.74
277/480		60		5.0/2.9	1.5 SF1.2	1745	0.72
50/60Hz: IE3 85.3/86.5(100%) 86.1/87.3(75%) 85/85.5(50%)							
60Hz NEMA NOM. EFF. 86.5% 2 hp DES.C CODE. L/L							

UTC 2370

MOT.3~N.1801516 06/16	IP 55	AMB. 40°C	IC 411	V~/Hz A #/## V=			
HB3 112M 4 B5	kg 33	I.CL. F	S 1				
DE/NDE		h		g			
R000145817		7723530					
NEMA MG1-12 SF 1,15 CONT. DESIGN A CODE M							
YY V Y	Hz	A	HP	RPM	PF	NOM. EFF	
230/460	60	10,6/5,3	4	1750	79%	89,5%	
ENERGY Verified for energy efficiency in accordance with US DOE 10CFR431, dated September 22, 2015							
Verified for energy efficiency in accordance with CSA C390-10, dated March 2010, reaffirmed 2015							
CC131B E304505							

UTC 2163A

Standard voltage/frequency on name plate

Motors required with supply voltage $\Delta 230$ Y400V 50Hz are supplied as standard with the following voltage/frequency values stated on motor nameplate, see following table:

Motor type	Voltage/Frequency on nameplat	Voltage/Frequency on nameplate with design ,UL (42)
HB	230.400 50 265.460.60	230.400 50 265.460.60
HB2	220.380 50 230.400 50 240.415 50 265.460 60 277.480 60	230.400 50 265.460 60 277.480 60
HB3 2, 4 Poles	220.380 50 230.400 50 240.415 50 265.460 60 277.480 60	230.400 50 265.460 60 277.480 60
HB3 6 Poles	220.380 50 230.400 50 240.415 50	230.400 50

Other voltage types are available on request as already explained in the design (1) "Non-standard motor supply", in the specific case only the required supply will be stated on nameplate.

Brake motor for gearmotors HBZ

Section Contents

4.1	General specifications	72
4.2	Designation	73
4.3	Specifications	73
4.4	Radial and axial loads on shaft end	77
4.5	Motor brake specifications	78
4.6	Technical data 400V 50 Hz	80
4.7	Technical data 230.460V 60 Hz	86
4.8	Technical data 380V 60 Hz	90
4.8	Motor dimensions	92
4.9	Non-standard designs and accessories	95
4.10	Name plate	107
4.11	Standard voltage/frequency on name plate	108

4.1

General specifications

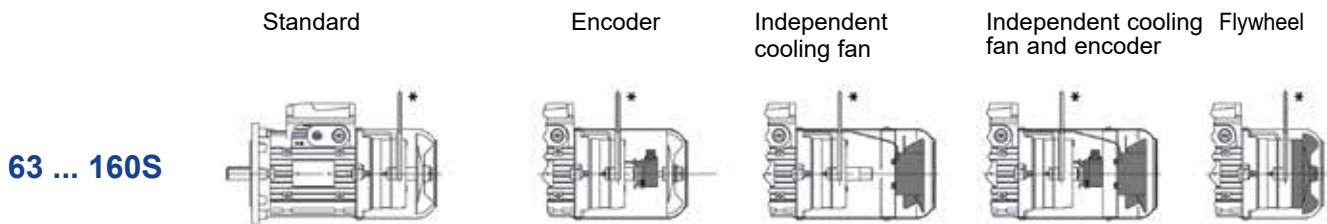

* On request.

- Series of brake motors with d.c. brake suitable for universal use and especially for gearmotors applications.
- Sizes 63 ... 160S available also with **powers** (marked by*) **higher than the ones foreseen by the standards**
- Class F insulation; temperature rise class B for all motors at standard power, F for remaining motors
- Mounting position **IM B5** and derivatives, **IM B14** and derivatives and **IM B3** and corresponding vertical mounting positions; **mating tolerance under «accuracy» rating**
- **IP 55** protection
- **Particularly strong construction** (both electrical and mechanical) to withstand alternating torsional and thermic stresses of starting and braking; duly proportioned bearings
- **«Supported» tightening attachments** of endshields and flanges fitted on housing with **«tight»** coupling
- Electromagnetic sizing especially studied to allow high acceleration capacity (**high frequency of starting**) and uniform starting
- **Suitable for operation with inverter**
- **Asbestos-free** friction surfaces
- **Wide metallic** terminal box, **multi-voltage rectifier, one brake coil only, for voltage always co-ordinated with motor** (both D and Y)
- Double braking surface, braking torque proportioned to motor torque (usually $M_f \approx 2M_N$)
- **Maximum reduced noise level** and operation **progressivity** (both at starting and braking) thanks to a lower rapidity (**typical of d.c. brake**) of the anchor (which is lighter and less quick in the impact): motor starts slightly braked i.e. with greater progressivity; good release and braking rapidity; possibility to increase rapidity when braking, with supply opening on d.c. side
- High braking capacity
- **Designs available for every application need** (flywheel, encoder, independent cooling fan, independent cooling fan and encoder, protections higher than IP 55: IP 56, IP 65)
- Particularly suitable for applications requiring regular and low-noise starting and braking and, at the same time, braking with good rapidity and precision and high number of starts.

For standard voltages as per name plate see ch. 4.11

Designation

	MOTOR	HB	asynchronous three phase
	EFFICIENCY CLASS	–	$P_N \geq 0,75 \text{ kW}$ Duty S3 70%
	BRAKE TYPE	Z	d.c. brake
	SIZE	63 ... 160S	
	NUMBER OF POLES	2, 4, 6	
	SUPPLY¹⁾	230.400-50 230.460-60²⁾	$\Delta 230 \text{ Y}400 \text{ V } 50 \text{ Hz}$ $YY 230 \text{ Y}460 \text{ V } 60 \text{ Hz}$
	MOUNTING POSITION	B5, B14, B3, B5R, B5A, ... B14R	IM B5, IM B14 (63 ... 132), IM B3, non-standard IM B5 non-standard IM B14
	Non-standard design ,.... ,....	code, see ch. 4.9

HB	Z	80	B	2	230.400-50	B5R ,E1
HB 2	Z	71	B	4	230.400-50	B5R
HB 3	Z	90	L	4	230.400-50	B5

1) May frequency and voltage differ from those stated above, see ch. 4.9 (1).

2) Motor supply for USA and Canada (EISA): includes terminal block with 9 terminals and UL compliance (see ch. 4.9 (42)); not possible for 8 pole motors

Specifications

Asynchronous three-phase electric **brake motor** with **d.c. brake** (braking in case of failure of supply) with double braking surface, sizes **63 ... 160S**;

Standardised motor with cage rotor, totally enclosed, externally ventilated (cooling system IC 411), single-speed according to following tables:

Number of poles	Winding	Motor size	Standard supply		insulation	Class temperature rise
			50 Hz	60 Hz		
2, 4, 6	three-phase Δ Y	63 ... 160S	50 Hz	see ch. 4.10	F	B ¹⁾
4, 6	three-phase YY Y		60 Hz	YY 230 Y460 V		

1) Excluding some motors with higher power than the ones standardised (identified by □ at ch. 4.6 and 4.7) whose temperature rise class is F.

«Torque-speed» **characteristic curves** duly optimized for handling (horizontal and vertical traverse movements, rotation), slightly «sagged», without peaks in the hypersynchronous area and with carefully proportioned mean value.

Rated power delivered on continuous duty (S1) and at standard voltage and frequency; ambient temperature $-15 \div +40 \text{ }^\circ\text{C}$, altitude 1 000 m.

IP 55 protection: drive end with seal ring (without spring for IM B3) and non-drive end with water-proof and dust-proof gaiter and V-ring.

Mounting positions IM B5, IM B3 IM B14; motors can also operate in the relevant mounting positions with vertical shaft, which are respectively (see following table): IM V1 and IM V3, IM V18 and IM V19, IM V5 and IM V6; the name plate shows the designation of mounting position with horizontal shaft. On request, other special mounting positions: consult Rossi S.p.A.

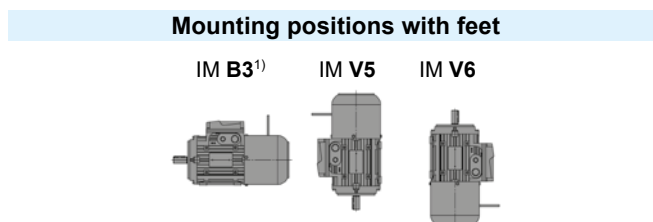
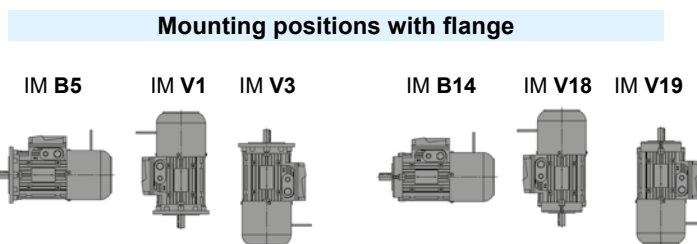

1) Motor can also operate in the mounting positions IM B6, IM B7 and IM B8; the name plate shows the IM B3 mounting position.

Main mating dimensions of the mounting positions with flange

Mounting position	Shaft end - Ø D x E Flange - Ø P								
	Motor size								
	IM	63	71	80	90	100	112	132	160S
B3	11 x 23	14 x 30	19 x 40	24 x 50	28 x 60	28 x 60	38 x 80	42 x 110	
B5	11 x 23 140	14 x 30 160	19 x 40 200	24 x 50 200	28 x 60 250	28 x 60 250	38 x 80 300	42 x 110 350	
B5R	9 x 20 120	11 x 23 140	14 x 30 160	19 x 40 200	24 x 50 200	24 x 50 200	28 x 60 250		-
B5S	-	-	-	14 x 30 160 ¹⁾	19 x 40 200	19 x 40 200 ¹⁾	24 x 50 200 ¹⁾		-
B5A	11 x 23 120	14 x 30 140	19 x 40 160	-	28 x 60 200	28 x 60 200	38 x 80 250		-
B5B	-	11 x 23 120	14 x 30 140	19 x 40 160	-	-	28 x 60 200		-
B5C	-	-	-	-	19 x 40 160	-	-		-
B14	11 x 23 90	14 x 30 105	19 x 40 120	24 x 50 140	28 x 60 160	28 x 60 160	38 x 80 200		-
B14R	-	11 X 23 90	14 x 30 105	-	-	-	-		-

1) For $P_{N \max}$ available see table below.

Motor size	Poles					
	2		4		6	
	$P_{N \max}$ kW [hp]					
90	1,85	[2.4]	1,1	[1.5]	0,75	[1]
112	4	[5.4]	3	[4]	1,85	[2.4]
132	9,2	[12.4]	7,5	[10]	4	[5.4]

Housing in pressure diecast light alloy; mounting position IM B3 with inserted feet which, for sizes 90 ... 160S can be mounted on **three sides**.

Drive end (or flange) and non-drive end endshield in cast iron or light alloy (see table below).

«**Supported**» **tightening attachments** of endshields and flanges fitted on housing with «**tight**» coupling.

Ball bearings (see table below) lubricated «for life» assuming pollution-free surroundings; preload spring.

Driving shaft in through-hardened steel 39 NiCrMo3 or C45 depending on size, **axially fastened** on rear endshield. Cylindrical shaft ends with A-shape (rounded) key and tapped butt-end hole (see table, where: d = tapped butt-end hole; bxhxl = key dimensions).

Rear threaded hole for dismantling in applications with gear reducer, as standard.

Motor size	Endshield material and bearings	
	drive end	non-drive end
63	LL 6202 2Z	6202 2Z LL
71	LL 6203 2Z	6203 2Z LL
80	LL 6204 2Z	6204 2Z LL
90	LL 6205 2Z	6205 2Z LL
100	LL 6206 2Z	6206 2Z LL
112	LL 6306 2Z	6306 2Z LL
132	LL ¹⁾ 6308 2Z	6308 2Z LL
160S	G 6309 2Z	6308 2Z LL

LL = light alloy G = cast iron

1) In cast iron for IM B14 and IM B5 derivatives.

	Shaft end - Ø × E							
	Ø 9×20	Ø 11×23	Ø 14×30	Ø 19×40	Ø 24×50	Ø 28×60	Ø 38×80	Ø 42×110
d	M3	M4	M5	M6	M8	M10	M12	M16
b×h×l	3×3×12	4×4×18	5×5×25	6×6×32	8×7×40	8×7×50	10×8×70	12×8×100

Steel fan cover.

Thermoplastic **cooling fan** with radial blades.

Terminal box in light alloy (integral with housing with cable knockout openings on both sides, two openings per side one for power cable and one for auxiliary equipments).

Position opposite to feet for mounting position IM B3; on request available on right or left side (see ch. 4.9.(14). Pressure diecast light alloy.

Terminal block with 6 terminals (9 terminals for YY230 Y460 60 Hz voltage supply); terminal dimensions in the table on the left.

Motor size	Terminal block		Seal rings
	terminals ¹⁾	cable entry ²⁾	
63	M4	4 × M16	15 × 30 × 4,5
71	M4	2 × M16 + 2 × M20	17 × 32 × 5
80	M4	2 × M16 + 2 × M20	20 × 35 × 7
90	M5	2 × M16 + 2 × M25	25 × 46 × 7
100, 112	M5	2 × M16 + 2 × M25	30 × 50 × 7
132	M6	2 × M16 + 2 × M32	40 × 60 × 10
160S	M6	2 × M16 + 2 × M32	45 × 65 × 10 ³⁾

1) 6 terminals for cable terminal connection.

2) Terminal box provided with knockout openings (for sizes 63 ... 160S cable gland not supplied).

3) Non-drive end: 40x60x10.

Earth terminal located inside terminal box; prearranged for the installation of two further external earth terminals on housing.

Brake supply: with rectifier laying in terminal box having 2 terminals for cable connection for rectifier supply and 2 for external contact of fast braking; possible brake supply **directly from** motor **terminal block** or **separately** (to be used for: motors supplied by inverter, separate drive needs of motor and brake, etc.).

Brake can be supplied, also at motor standstill, with no time limitations.

Pressure diecast cage **rotor** in aluminium.

Stator winding with class H copper conductor insulation, insulated with double coat, type of impregnation with resin of class H; other materials are of classes F and H for a **class F insulation system**.

Rotor dynamic balancing: vibration velocity under standard rating A. Motors are balanced with half key inserted into shaft extension.

Paint: double-compound, water-soluble, polyacrylic resin based, corrosivity class C3 (to ISO 12844-2), colour blue RAL 5010 DIN 1843, unaffected by normal industrial environments and suitable for further finishings with double-compound synthetic paints.

For **non-standard designs** and accessories see ch. 4.9.

Compliance with European Directives

Motors of present catalog comply with following standards: EN 60034-1, EN 60034-2-1, EN 60034-2, EN 60034-5, EN 60034-6, EN 60034-7, EN 60034-8, EN 60034-9, EN60034-12, EN 60034-14, IEC 60038, IEC 60072-1, and with **Low Voltage Directive 2014/35/EU**.

For this reason the electric motors are CE marked.

Additional information:

The motor design, considering the motors as components, complies with:

- Machinery Directive 2006/42/EC when the installation is correctly executed by machinery manufacturer (e.g.: in compliance with our installation instructions and EN 60204 «Electric Equipments of Industrial Machines»);
- Directive 2011/65/EC RoHS relevant to the limit of use of dangerous substances in the electric and electronic equipments.

Declaration of Incorporation (Directive 2006/42/EC Art 4.2 - II B):

The above mentioned motors must be commissioned as soon as the machines in which they have been incorporated have been declared to be in compliance with the Machinery Directive.

According to EN 60034-1, as motors are components and not machines, supplied directly to the final user, the Electromagnetic Compatibility Directive (application of Directive 2014/30/EU) is not directly applicable.

Radial and axial loads on shaft end

Radial loads generated on the shaft end by a drive connecting motor and driven machine must be less than or equal to those given in the relevant table.

The radial load F_r , given by the following formula refers to most common drives:

$$F_r = \frac{k \cdot 19100 \cdot P}{n \cdot d} \text{ [N]}$$

where:

P [kW] is motor power required

n [min^{-1}] is the speed

d [m] is the pitch diameter

k is a coefficient assuming different values according to the drive type:

$k = 1$ for chain drive

$k = 1,1$ for gear pair drive

$k = 1,5$ for timing belt drive

$k = 2,5$ for V-belt drive

The table shows maximum permissible values of radial and axial loads on driving shaft end (F_r overhung load on centre line of shaft end), calculated for a bearing life $L_h = 18000$ h. For a longer bearing life, the values stated in the table must be multiplied by:

0,9 (25000 h),

0,8 (35500 h) or

0,71 (50000 h).

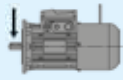
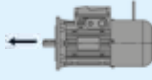
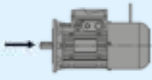
Motor size	$F_r^{1)}$ [N]				$F_a^{2)}$ [N]							
												
	n_N [min^{-1}]				n_N [min^{-1}]				n_N [min^{-1}]			
	3000	1500	1000	750	3000	1500	1000	750	3000	1500	1000	750
63	420	530	600	670	200	290	350	400	210	290	350	400
71	510	640	740	810	210	310	380	440	210	310	380	440
80	650	830	950	1050	230	350	420	500	370	500	600	680
90S	710	900	1040	1140	250	390	490	570	250	390	490	570
90L	730	930	1050	1180	240	380	480	560	240	380	480	560
100	1000 ³⁾	1300	1500	1650	300	490	620	730	370	570	710	820
112	1500 ³⁾	1900	2150	2400	660	950	1150	1310	660	950	1150	1310
132	2000 ³⁾	2500	3000	3250	1220	1650	1960	2200	1220	1650	1960	2200
160S	2500	3150	3650	4050	1720	2280	2670	2990	1220	1650	1960	2200

1) An axial load of up to 0,2 times the value in the table is permissible, simultaneously with the radial load.

2) Comprehensive of a possible unfavourable effect of weight-force of rotor and bearing preload spring.

3) For radial load value near to table limit require bearings C4.

For running at 60 Hz, table values must be reduced by 6%.

4.5

Motor brake specifications

63 ... 160S

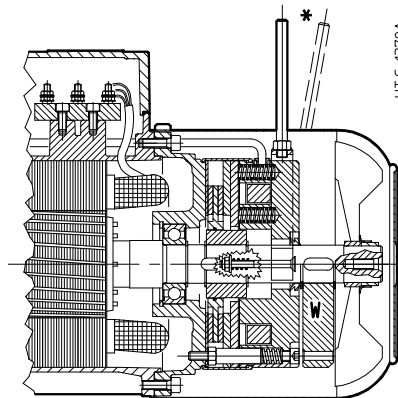

* On request

Electromagnetic spring loaded brake (braking occurs automatically when it is not supplied), with **d.c.** toroidal coil and double braking surface, braking torque **proportioned** to motor torque (usually $M_f \approx 2 M_N$).

Conceived for **maximum reduced noise level of running** and **progressivity** of on-off switching (both when starting and when braking thanks to lower rapidity, typical of d.c. brake, of brake anchor, lighter and less quick in the impact: motor starts slightly braked and with greater progressivity) **with increased rapidity in releasing and braking**; possibility to increase the rapidity, both in releasing (with rapid rectifier) and braking with supply opening on d.c. side, outstanding work capacity.

Wide range of non-standard designs (flywheel, encoder, independent cooling fan, independent cooling fan with encoder, second shaft end, etc.).

Particularly suitable for applications requiring regular and low-noise starting and braking and, at the same time, braking with good rapidity and precision and high number of starts.

When electromagnet is not supplied, the brake anchor pushed by springs presses the brake disk on rear endshield generating the braking torque on the same brake disk and consequently on motor shaft it is keyed onto; by supplying the brake the electromagnet draws the brake anchor and releases the brake disk and driving shaft.

Main specifications:

- alternate single-phase **supply voltage** of rectifier (always supplied in terminal box)
 - **110 ÷ 440 V c.a.**, (brake 12 ... 15) or **200 ÷ 440 V c.a.**, (brake 06S ... 07) **50 ÷ 60 Hz: multi-voltage rectifier** (as standard), properly designed to manage a **unique brake coil** with supply voltage **always co-ordinated** with **HBZ motor** standard voltage (Δ **230 Y400 V 50 Hz** and consequently also Δ **277 Y480 V 60 Hz**);
 - on request toher voltages, see ch. 4.9 (1) and (26);
- rectifier supply **directly from motor terminal block** or indifferently from **separate** line;
- braking torque adjustable by changing number of springs;
- **insulation class F, temperature rise class B**;
- brake disk, sliding on moving hub: with single steel coat and double friction surface with average friction coefficient for low wear;
- **brake anchor in two pieces** for greater rapidity of starting and reduced noise;
- **water-proof and dust-proof gaiter** and **V-ring** both to prevent polluting infiltrations from surroundings towards brake, and to avoid that wear dust of friction surface will be dispersed in the surroundings;
- **lever for manual release with automatic return** and removable level rod, on request; position of release lever corresponding to terminal box as in the schemes at point 4.9; on request, other possible positions; consult us;
- for other functional specifications see following tabe.

For main specifications of motor see ch. 4.3.

For non-standard designs see ch. 4.9.

Motor is **always equipped with a high reliable rectifier** fixed on terminal box providing adequate connecting terminals (2 for rectifier supply directly from motor terminal block or separate; 2 for external contact of rapid braking).

RM1¹⁾ rectifiers (standard for brakes 12 ÷ 14) and **RM2**¹⁾ (standard for brakes 05 ... 07) are a.c./d.c. supply devices with full-wave controlled bridge **able to supply a constant output voltage value independently from input voltage**; the d.c. brake is suitable to be supplied in the range of 110 - 440 V a.c. (for brake sizes 12 ÷ 15) and 200 ÷ 440 V a.c. (for brake sizes 06S ... 07) without having to change the coil. For this reason it is always co-ordinated with both motor voltages. In the range 200 ÷ 440 V a.c. it also has the speed-up function (for approximately the initial 400 ms a voltage higher than the nominal one is supplied to the brake coil, allowing to have a quicker brake release).

Moreover, compared to a conventional rectifier, the multivoltage rectifier offers the following advantages:

- higher steadiness of brake characteristics (being the output voltage set to a fixed value independent from the line fluctuations);
- lower voltage needed for feeding the brake (75 V d.c.) in release position (lower energy consumption, lower coil heating and lower braking delay).

All rectifier models can be connected-disconnected both on a.c. side (for maximum low noise running); both on a.c. and d.c. side (for a quicker braking release) as they are equipped with varistors for the protection of diodes, electromagnet and d.c. side opening contact (wiring schemes see ch. 7).

1) Multi-Voltage rectifier **RM1** and **RM2** are **patented** devices.

Table of main functional specifications of brake

Effective values may slightly differ according to ambient temperature and humidity, brake temperature and state of wear of friction surface.

Brake size	Motor size	M_f [N m] ± 12% spring number (primed)			Absorption			Delay of ²³⁾			Air-gap		W_1	C_{max}	$W_{max}^{28)}$ [J]			
								release	braking									
								t_1 ms 24)	t_2 ms 25)	t_2 C.C. ms 25)								
21)			V c.a.	A c.a. max	W				nom	max	MJ/mm 26)	mm 27)	brakings/h					
														10	100	1000		
BZ 12	RM1	63, 71	1,75 ²	3,5 ⁴	–	110 ÷ 440	0,09	9	20	100	10	0,25	0,40	70	5	4500	1120	160
BZ 53, 13	RM1	71, 80	2,5 ²	5 ⁴	7,5 ⁶	110 ÷ 440	0,14	12	32	120	10	0,25	0,40	90	5	5600	1400	200
BZ 04, 14	RM1	80, 90	5 ²	11 ⁴	16 ⁶	110 ÷ 440	0,20	16	45	150	10	0,30	0,45	125	5	7500	1900	265
BZ 05, 15	RM2	90, 100, 112	13 ²	27 ⁴	40 ⁶	110 ÷ 440	0,26	24	63	220	15	0,30	0,45	160	5	10000	2500	355
BZ 06S	RM2	112	25 ²	50 ⁴	75 ⁶	200 ÷ 440	0,28	30	90	300	30	0,35	0,55	220	5	14000	3550	500
BZ 56	RM2	132S	37 ²	75 ⁴	–	200 ÷ 440	0,28	50	90	224	20	0,35	0,55	224	4,5	14000	3550	500
BZ 06	RM2	132S ... 160S	50 ²	100 ⁴	–	200 ÷ 440	0,28	50	90	224	20	0,35	0,55	224	4,5	14000	3550	500
BZ 07	RM2	132M, 160S	50 ²	100 ⁴	150 ⁶	200 ÷ 440	0,34	65	125	280	25	0,40	0,60	315	4,5	20000	5000	710

21) Standard rectifier, supplied as standard; stop time must be **2,5 s ÷ 3,5 s**. If necessary, consult us.

23) Values valid with M_{fmax} , mean air-gap and nominal value of supply voltage.

24) Release time of brake obtained with standard rectifier and, for RM1, with supply voltage ≥ 200 V c.a..

25) Braking delay obtained by separate brake supply and coil disconnection on a.c. side of rectifier (t_2) or on a.c. and d.c. side (t_2 d.c.). With direct supply from motor terminal block, the values of t_2 increase of approx. 2,5 times the ones of table.

26) Friction work for brake disk wear of 1 mm (minimum value for heavy duty; real value is usually greater).

27) Maximum brake disk wear.

28) Maximum friction work for each braking.

4.6

Technical data 400V 50Hz

2 poles - 3000 min⁻¹

IP 55

IC 411

Insulation class F

Temperature rise class B

IE2 P_N 0,12 ... 0,55 kW

P_N ≥ 0,75 kW S3 70%

400V - 50Hz

ErP

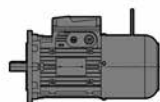

UT.C. 1373

P _N kW	Motor	n _N min ⁻¹	M _N N m	I _N A 400 V	cos φ	η			M _S / M _N	M _{max} / M _N	I _S / I _N	J ₀ kg m ²	Brake 1)	M _f N m	z ₀ starts/h	kg
						IEC 60034-2-1										
						100%	75%	50%								
0,18	HB2Z 63 A 2	2800	0,61	0,56	0,71	68,7	66,6	60,7	3,1	3,3	4,1	0,0002	BZ 12	1,75	4750	5,5
0,25	HB2Z 63 B 2	2780	0,86	0,75	0,71	70,5	68,9	63,1	3,1	3,2	4,1	0,0003	BZ 12	1,75	4750	6,1
0,37 *	HB2Z 63 C 2	2790	1,26	1,02	0,72	73,3	72,4	67,3	3,5	3,3	4,5	0,0003	BZ 12	3,5	4000	6,7
0,37	HB2Z 71 A 2	2800	1,26	0,95	0,77	75	74,7	70,8	3,1	3,3	5,2	0,0004	BZ 12	3,5	4000	7,7
0,55	HB2Z 71 B 2	2820	1,86	1,33	0,78	77,3	76,9	72,9	3,6	3,7	5,8	0,0005	BZ 53	5	4000	9,4
0,75 *	HBZ 71 C 2	2830	2,53	1,85	0,79	73,8	72,9	68,7	3,5	3,7	5,7	0,0006	BZ 53	5	3000	10
0,75	HBZ 80 A 2	2850	2,51	1,85	0,75	78,3	77,7	74,3	3,6	3,8	6,1	0,0009	BZ 13	5	3000	10,5
1,1	HBZ 80 B 2	2840	3,7	2,6	0,77	79,5	80,1	78,3	3,6	3,8	6,1	0,0011	BZ 04	11	3000	12,5
1,5 *	HBZ 80 C 2	2890	4,96	3,5	0,76	81,2	81,4	78,9	4	4,4	7,4	0,0014	BZ 04	11	2500	14,5
1,85 *	HBZ 80 D 2	2820	6,3	4,2	0,80	79,8	81,2	80,1	3,7	3,8	6,2	0,0015	BZ 04	16	2500	15
1,5	HBZ 90 S 2	2840	5	3,4	0,81	78,5	78,9	77	3	3,2	5,7	0,0016	BZ 14	11	2500	17
1,85 *	HBZ 90 SB 2	2860	6,2	4,2	0,80	79,3	79,6	77,1	3,2	4	6,1	0,0018	BZ 14	16	2500	18,5
2,2	HBZ 90 LA 2	2880	7,3	4,9	0,80	81	80,7	78	3,8	4,5	7	0,0024	BZ 05	27	2500	23
3 *	HBZ 90 LB 2	2870	10	6,6	0,80	82	82,2	80,1	3,7	4,1	6,8	0,0028	BZ 05	27	1800	25
3	HBZ 100 LA 2	2860	10	6,8	0,78	81,5	82	80,1	3,6	3,8	6	0,0035	BZ 15	27	1800	26
4 *	HBZ 100 LB 2	2860	13,4	8,8	0,79	83,1	82,5	80	3,8	4,4	7	0,0046	BZ 15	27	1500	30
4	HBZ 112 M 2	2880	13,3	8,8	0,79	83,3	83,6	82	3	3,8	6,2	0,0054	BZ 15	27	1500	33
5,5 *	HBZ 112 MB 2	2890	18,2	11,6	0,81	84,7	84,9	83,2	3,3	3,7	7,2	0,0072	BZ 15	40	1400	37
7,5 *	HBZ 112 MC 2	2870	25	16,5	0,79	83	84,4	83,7	3	3,7	6,4	0,0085	BZ 06S	50	1060	42
5,5	HBZ 132 S 2	2900	18,1	11,3	0,83	84,7	84,3	82,1	2,6	3,4	6,3	0,0112	BZ 06	50	1250	54
7,5	HBZ 132 SB 2	2910	24,6	14,3	0,87	86,9	87,2	85,5	2,9	3,7	7,2	0,0146	BZ 06	50	1120	57
9,2 *	HBZ 132 SC 2	2910	30,2	18,7	0,82	87	87,3	85,67	3	3,8	7,7	0,0168	BZ 56	75	1060	59
11 *	HBZ 132 MA 2	2920	36	20,5	0,88	87,6	87,5	85,9	3,2	3,9	8,3	0,0202	BZ 06	100	850	66
15 *	HBZ 132 MB 2	2920	49,1	30	0,85	88,7	86,2	84	3,7	4,1	8,3	0,0258	BZ 06	100	710	77
11	HBZ 160 SA 2	2920	36	20,5	0,88	87,6	87,5	85,9	3,2	3,9	8,3	0,0202	BZ 06	100	850	75
15	HBZ 160 SB 2	2920	49,1	30	0,83	88,7	86,2	84	3,9	4,3	8,3	0,0258	BZ 06	100	710	86

Efficiency value not complying with IE3 class range (IEC 60034-30); nominal power and name plate referred to S3 70% intermittent duty.

2) For design with flywheel motor size-brake size pairings are stated at ch. 4.9 (23).

* Power or motor power-to-size correspondence not according to standard.

□) Temperature rise class F.

Technical data 400V 50Hz

2 poles - 3000 min⁻¹

IP 55

IC 411

Insulation class F

Temperature rise class B

IE3
400V - 50Hz
ErP

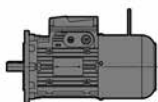

UT.C. 1373

P _N	Motor	n _N	M _N	I _N	cos φ	η			M _S /M _N	M _{max} /M _N	I _S /I _N	J ₀	Brake	M _f	z ₀	kg	
						IE3 IEC 60034-2-1											
kW		min ⁻¹	N m	A 400 V		100%	75%	50%			kg m ²		N m	starts/h			
0,75	HB3Z80 A	2	2870	2,5	1,7	0,78	80,7	79,9	76,7	3,6	3,8	7,3	0,001	BZ 13	5	2500	10,7
1,1	HB3Z80 B	2	2875	3,7	2,3	0,84	82,7	83,2	81	3,9	3,9	7,7	0,0015	BZ 04	11	2500	15,5
1,5	HB3Z90 S	2	2890	4,97	2,9	0,88	84,2	84,5	83,3	3,3	3,6	7,9	0,0021	BZ 14	11	1800	20
2,2	HB3Z90 LA	2	2890	7,3	4,4	0,85	85,9	86,2	85,1	3,9	4,4	8,4	0,0027	BZ 05	27	1600	24
3	HB3Z100 LA	2	2930	9,8	6,2	0,80	87,1	87,2	85,2	4,2	5,1	10,1	0,0048	BZ 15	27	1500	30
4	HB3Z112 M	2	2940	13	7,6	0,87	88,1	88,2	86,7	2,8	4,2	9,8	0,0078	BZ 15	27	1400	39
5,5	HB3Z132 S	2	2960	17,8	10,4	0,85	89,2	88,6	85,6	5,2	6,1	12,7	0,0184	BZ 06	50	710	64
7,5	HB3Z132 SB	2	2960	24,3	14	0,85	90,1	89,9	87,3	5,7	6,5	13,6	0,0225	BZ 06	50	710	72,5
9,2	* HB3Z132 SC	2	2960	29,7	17,3	0,84	90,7	89,9	87,4	5,7	6,3	13,4	0,0253	BZ 56	75	710	78
11	* HB3Z132 MA	2	2950	35,7	20	0,87	91,2	90,1	88,4	5,2	4,9	11,6	0,0253	BZ 06	100	710	78
11	HB3Z160 SA	2	2950	35,7	20	0,87	91,2	90,1	88,4	5,2	4,9	11,6	0,0253	BZ 06	100	710	87

1) For design with flywheel motor size-brake size pairings are stated at ch. 4.9 (23).

* Power or motor power-to-size correspondence not according to standard.

4.6

Technical data 400V 50Hz

4 poles - 1500 min⁻¹

IP 55

IC 411

Insulation class F

Temperature rise class B

IE2 P_N 0,12 ... 0,55 kW

P_N ≥ 0,75 kW S3 70%

400V - 50Hz

ErP

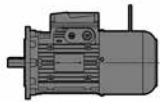

UT.C. 1373

P _N kW	Motor	n _N min ⁻¹	M _N N m	I _N A 400 V	cos φ	η			M _S / M _N	M _{max} / M _N	I _S / I _N	J ₀ kg m ²	Brake 1)	M _f N m	z ₀ starts/h	
						IEC 60034-2-1										
						100%	75%	50%								
0,12	HB2Z 63 A 4	1 370	0,84	0,46	0,63	61,4	58,9	51,9	2,5	2,6	3,1	0,0003	BZ 12	1,75	12500	5,7
0,18	HB2Z 63 B 4	1350	1,28	0,64	0,66	65	64,1	58,4	2,6	2,5	3,3	0,0004	BZ 12	3,5	12500	6,3
0,25 *	HB2Z 63 C 4	1360	1,76	0,83	0,65	68,5	67,8	62,8	2,8	2,7	3,5	0,0004	BZ 12	3,5	10000	7,1
0,25	HB2Z 71 A 4	1 400	1,71	0,8	0,71	68,5	66,6	60,7	2,3	2,6	3,8	0,0008	BZ 53	5	10000	8,4
0,37	HB2Z 71 B 4	1 400	2,52	1,1	0,70	73,2	72,2	67,3	2,7	3,2	4,6	0,001	BZ 53	5	10000	9,3
0,55 *	HB2Z 71 C 4	1 400	3,75	1,5	0,70	77,1	75,7	72	3,3	3,5	5,1	0,0014	BZ 53	7,5	8000	11
0,75 *	HBZ 71 D 4	1 370	5,2	2,15	0,70	72,1	73,3	69,1	2,8	2,9	4	0,0014	BZ 53	7,5	7100	11
0,55	HB2Z 80 A 4	1 420	3,69	1,34	0,78	77,1	76	72	2,9	3,1	5,8	0,0025	BZ 04	11	8000	13
0,75	HBZ 80 B 4	1 410	5,1	1,9	0,77	74,7	74,2	70,5	2,8	3	5,2	0,0025	BZ 04	11	7100	13
1,1 *	HBZ 80 C 4	1 400	7,5	2,8	0,79	75	75,6	72	2,9	3	5,2	0,0033	BZ 04	16	5000	15
1,1	HBZ 90 S 4	1 410	7,4	3	0,70	75,2	74,7	70	2,6	2,9	4,4	0,0025	BZ 14	16	5000	17
1,5	HBZ 90 L 4	1 410	10,2	3,9	0,71	77,2	79	74,5	3,2	3,6	5,2	0,0037	BZ 05	27	4000	22
1,85 *	HBZ 90 LB 4	1 400	12,6	4,5	0,76	78,6	80	77,1	2,9	3,2	5,1	0,004	BZ 05	27	4000	23
2,2 * □	HBZ 90 LC 4	1 400	15	5,7	0,70	79,7	80,3	77,2	2,8	3,2	4,9	0,0045	BZ 05	40	3150	25
2,2	HBZ 100 LA 4	1 420	14,8	5,1	0,78	80	80,8	79,2	2,7	3,2	5,1	0,0054	BZ 15	40	3150	26
3	HBZ 100 LB 4	1 425	20,1	6,9	0,76	82,8	83,7	82	2,8	3,2	5,5	0,0072	BZ 15	40	3150	30
4	HBZ 112 M 4	1 430	26,7	9,2	0,75	83,4	84,1	82,6	3	3,4	6	0,0117	BZ 06S	75	2500	39
5,5 * □	HBZ 112 MC 4	1 420	37	12,3	0,76	84,7	86,1	85,7	3	3,4	6,1	0,0139	BZ 06S	75	1800	42
5,5	HBZ 132 S 4	1 450	36,2	12,2	0,76	86,3	86,9	85,7	3,2	3,4	6,3	0,0245	BZ 56	75	1800	56
7,5	HBZ 132 M 4	1 450	49,4	15,8	0,79	87,1	87,7	86,5	3,4	3,6	7	0,033	BZ 06	100	1250	65
9,2 *	HBZ 132 MB 4	1 450	61	19,5	0,77	88	89,4	87,6	3,5	3,8	7,2	0,0399	BZ 07	150	1060	72
11 * □	HBZ 132 MC 4	1 450	72	23	0,78	87,8	88,2	87	3,5	3,8	7,3	0,0455	BZ 07	150	900	78
11 □	HBZ 160 SC 4	1 450	72	23	0,78	87,8	88,2	87	3,5	3,8	7,3	0,0455	BZ 07	150	900	87

Efficiency value not complying with IE3 class range (IEC 60034-30); nominal power and name plate referred to S3 70% intermittent duty.

1) For design with flywheel motor size-brake size pairings are stated at ch. 4.9 (23).

* Power or motor power-to-size correspondence not according to standard.

□) Temperature rise class F.

Technical data 400V 50Hz

4 poles - 1500 min⁻¹

IP 55

IC 411

Insulation class F

Temperature rise class B

IE3
400V - 50Hz
ErP

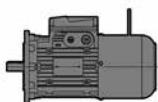

UT.C 1373

P _N	Motor	n _N	M _N	I _N	cos φ	η			M _S /M _N	M _{max} /M _N	I _S /I _N	J ₀	Brake	M _f	z ₀	kg
						IE3 IEC 60034-2-1										
kW		min ⁻¹	N m	A 400 V		100%	75%	50%			kg m ²		N m	starts/h		
0,75	HB3Z 80 B 4	1410	5,1	2	0,67	82,5	82,2	80,1	3,2	3,3	5,3	0,002	BZ 04	11	6800	16
1,1	HB3Z 90 S 4	1420	7,4	2,4	0,80	84,1	84,8	83,6	3,0	3,5	6,4	0,0043	BZ 14	16	3150	22,5
1,5	HB3Z 90 L 4	1430	10,1	3,3	0,78	85,3	86,1	85	3,1	3,7	6,7	0,0047	BZ 05	27	3000	25
1,85 ²⁾	HB3Z 90 LB 4	1425	12,4	4,3	0,73	86	85,3	83,4	3,4	3,7	6,4	0,0047	BZ 05	27	3000	25
2,2	HB3Z100 LA 4	1440	14,6	4,8	0,76	86,7	87,2	85,5	3,5	4,4	7,4	0,008	BZ 15	40	3000	32
3 *	HB3Z112 MA 4	1450	19,8	6,1	0,80	88,7	88,6	87,3	3,5	4,4	8,8	0,013	BZ 15	40	2000	39
4	HB3Z112 M 4	1450	26,3	8,5	0,77	88,6	89,2	88	3,7	4,6	9,0	0,015	BZ 06S	75	1800	44
5,5	HB3Z132 S 4	1470	35,8	12	0,74	89,6	89,5	87,6	4,5	5,0	9,1	0,0367	BZ 56	75	900	69
7,5	HB3Z132 M 4	1460	49	15,2	0,79	90,4	90,4	89,6	3,9	4,2	8,4	0,0442	BZ 06	100	900	77
9,2 *	HB3Z132 MB 4	1460	60,2	19,2	0,76	91	90,8	90,1	4,0	4,1	8,5	0,047	BZ 07	150	800	80,5

1) For design with flywheel motor size-brake size pairings are stated at ch. 4.9 (23).

* Power or motor power-to-size correspondence not according to standard.

2) Available only for 50Hz voltages

4.6

Technical data 400V 50Hz

6 poles - 1000 min⁻¹

IP 55

IC 411

Insulation class F

Temperature rise class B

IE2 P_N 0,12 ... 0,55 kW
P_N ≥ 0,75 kW S3 70%
400V - 50Hz
ErP

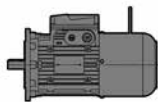

UT.C. 1373

P _N kW	Motor	n _N min ⁻¹	M _N N m	I _N A 400 V	cos φ	η			M _S / M _N	M _{max} / M _N	I _S / I _N	J ₀ kg m ²	Brake 1)	M _f N m	z ₀ starts/h	
						IEC 60034-2-1										
						100%	75%	50%								
0,09	HBZ 63 A 6	900	0,95	0,48	0,57	47,6	43,1	34,4	2,5	2,6	2,3	0,0004	BZ 12	1,75	12500	5,9
0,12	HB2Z 63 B 6	900	1,27	0,55	0,59	52,2	48,3	40,1	2,7	2,8	2,5	0,0005	BZ 12	3,5	12500	6,3
0,15 *	HB2Z 63 C 6	875	1,64	0,62	0,64	55,6	53,2	46	2,5	2,5	2,6	0,0006	BZ 12	3,5	11800	6,9
0,18	HB2Z 71 A 6	900	1,91	0,66	0,67	59,5	57,1	49,8	2,4	2,4	3	0,001	BZ 53	5	11200	8,7
0,25	HB2Z 71 B 6	900	2,64	0,88	0,67	61,8	59,7	52,9	2,5	2,7	3,3	0,0013	BZ 53	5	11200	9,5
0,37 *	HB2Z 71 C 6	895	3,95	1,2	0,69	67,6	66,1	61	2,6	2,3	3,5	0,0018	BZ 53	7,5	10000	11,1
0,37	HB2Z 80 A 6	910	3,9	1,2	0,67	67,6	64	57,8	2,7	2,6	3,6	0,0021	BZ 04	11	9500	12
0,55	HB2Z 80 B 6	930	5,6	1,6	0,67	73,1	72,2	67,7	3	3	4,5	0,0033	BZ 04	16	9000	15
0,75*	HBZ 80 C 6	920	7,8	2,3	0,67	70,1	69,7	64,5	2,5	2,7	3,8	0,0033	BZ 04	16	7100	15
0,75	HBZ 90 S 6	920	7,8	2,2	0,68	72,1	72	67,9	2,4	2,4	3,7	0,0042	BZ 14	16	7100	17,5
1,1	HBZ 90 L 6	915	11,5	3,2	0,68	72,9	72	69,3	2,6	2,8	3,9	0,0059	BZ 05	27	5300	23
1,5 * □	HBZ 90 LC 6	910	15,7	4,3	0,68	73,8	72,5	70	2,7	2,9	4,3	0,0069	BZ 05	40	5000	25
1,5	HBZ 100 LA 6	930	15,4	3,9	0,73	75,5	75,4	71,6	2,8	3	4,8	0,0099	BZ 15	40	3550	27
1,85 *	HBZ 100 LB 6	930	19	4,9	0,71	76,6	76,2	72,1	3	3,2	5	0,0121	BZ 15	40	3150	30
2,2	HBZ 112 M 6	940	22,3	5,4	0,75	78,7	79,7	78,1	2,1	2,5	6,5	0,0157	BZ 06S	50	2800	36
3 * □	HBZ 112 MC 6	940	30,5	7,2	0,76	79,7	81,2	80,2	2,3	2,7	5,1	0,0197	BZ 06S	75	2500	41
3	HBZ 132 S 6	960	29,8	7,8	0,68	82,1	82,3	80,2	2,3	3	6	0,0305	BZ 56	75	2360	53
4	HBZ 132 M 6	960	39,8	9,7	0,72	83,2	83,7	81,8	2,5	3	6,7	0,0394	BZ 06	100	1400	60
5,5	HBZ 132 MB 6	960	55	12,9	0,73	84	84,8	83,4	2,6	3	7	0,0509	BZ 07	150	1250	70
7,5 * □	HBZ 132 MC 6	950	75	17,6	0,73	84,7	85	83,8	2,4	2,8	5,7	0,0611	BZ 07	150	1000	78
7,5 □	HBZ 160 SC 6	950	75	17,6	0,73	84,7	85	83,8	2,4	2,8	5,7	0,0611	BZ 07	150	1000	87

Efficiency value not complying with IE3 class range (IEC 60034-30); nominal power and name plate referred to S3 70% intermittent duty.

1) For design with flywheel motor size-brake size pairings are stated at ch. 4.9 (23).

* Power or motor power-to-size correspondence not according to standard.

□) Temperature rise class F.

Technical data 400V 50Hz
460V 60Hz

6 poles - 1000 min⁻¹ 50Hz
1200 min⁻¹ 60Hz

IP 55

IC 411

Insulation class F

Temperature rise class B

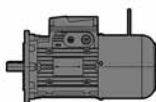

UT.C 1373

IE3
400V - 50Hz
460V - 60Hz
ErP

Supply	P_N kW	Motor	n_N min ⁻¹	M_N N m	I_N A 400 V	$\cos \varphi$	η IE3 IEC 60034-2-1			M_S / M_N	M_{max} / M_N	I_S / I_N	J_0 kg m ²	Brake M_f 1)		z_0 starts/h	
							100%	75%	50%					N m			
Y 400 V 50 Hz 2)	0,75	HB3Z 90 S 6	930	7,7	2	0,72	78,9	76	73	2,1	2,9	4,9	0,0057	BZ 14 16	7100	19,5	
	1,1	HB3Z 90 L 6	930	11,3	2,8	0,72	81	79	77	2,6	3	5,1	0,0071	BZ 05 27	5300	26	
	1,5	HB3Z 100 LA 6	950	15,1	3,5	0,75	82,5	82,4	80,4	2,5	3,4	6,5	0,0133	BZ 15 40	3000	32	
	2,2	HB3Z 112 M 6	960	21,9	5,1	0,73	84,3	85	83,2	2,3	3,5	6,9	0,0211	BZ 06S 50	2800	42	
	3	HB3Z 132 S 6	970	29,5	6,9	0,72	85,6	88	86,3	2,4	3,8	7,6	0,0445	BZ 56 75	1400	65	
	4	HB3Z 132 M 6	970	39,4	9,2	0,71	86,8	88,3	86,3	2,8	4,4	8,4	0,06	BZ 06 100	1250	77	
	5,5	HB3Z 132 MB 6	970	54,5	12,2	0,73	88	89,3	88,7	3,2	3,4	7,2	0,0623	BZ 07 150	1100	79	
Y 460 V 60 Hz 3)	0,75 *	HB3Z 100 LA 6	1160	6,1	1,6	0,71	82,5	84,2	80,9	2,9	4,4	7,9	0,013	BZ 15 13	3200	32	
	1,1 *	HB3Z 112 M 6	1160	9,1	2,2	0,73	87,5	88,2	86,8	2,5	3,4	6,3	0,0215	BZ 15 27	2500	40	
	1,5 *	HB3Z 112 MB 6	1160	12,3	3,1	0,70	88,5	88,2	86,5	3,0	3,9	6,9	0,0215	BZ 15 40	2000	40	
	2,2 *	HB3Z 132 S 6	1170	18	4,3	0,72	89,5	89,9	88,4	2,7	3,6	7,3	0,0358	BZ 06 50	1400	58	
	3 *	HB3Z 132 M 6	1170	24,5	5,8	0,72	89,5	90,2	88,7	2,8	3,8	7,6	0,0461	BZ 56 75	1000	67	
4	HB3Z 132 MB 6	1170	32,6	7,9	0,70	89,5	91	89,5	3,1	4,1	8,0	0,06	BZ 06 100	800	78		

1) For design with flywheel motor-size-brake size pairings are stated at ch. 4.9 (23).

2) Motor Size-power combinations available with name plate at 50 Hz only (for other voltage see ch. 4.9 (1)).

3) Motor Size-power combinations available with name plate at 60 Hz only (for other voltage see ch. 4.9 (1)).

*) Power or motor power-to-size correspondence not according to standard.

4.7

Technical data 230.460V 60Hz

4 poles - 1800 min⁻¹

IP 55

IC 411

Insulation class F

Temperature rise class B

Service factor **SF 1,15**

9 terminals



IE2 P_N 0,16 ... 0,75 hp

P_N ≥ 1 hp S3 70%

ErP

230.460V - 60Hz³⁾

NEMA MG1-12



UT.C 1373

P _N	Motor	n _N	M _N	I _N		PF	NEMA Nom. Eff. MG1-12	NEMA Code	M _S /M _N	M _{max} /M _N	I _S /I _N	J ₀	Brake	M _f	z ₀	
				A 230 V	A 460 V											
1) hp kW		1) RPM	N m			1) %	%					kg m ²		N m		
0,16 0,12	HBZ 63A 4	1690	0,68	0,84	0,42	58	64	J	3,1	3,1	3,6	0,0003	BZ12	1,75	10000	5,7
0,25 0,18	HBZ 63B 4	1680	1,02	1,18	0,59	6	69	J	3,3	3,1	3,8	0,0004	BZ12	3,5	10000	6,3
0,33 0,25 *	HBZ 63C 4	1690	1,42	1,5	0,75	59	72,3	J	3,5	3,5	4,2	0,0004	BZ12	3,5	8000	7,1
0,33 0,25	HBZ 71A 4	1720	1,39	1,4	0,7	65	70,9	K	2,8	3,3	4,8	0,0008	BZ53	5	8000	8,4
0,5 0,37	HBZ 71B 4	1720	2,06	1,9	0,95	65	76	K	3,1	3,8	5,3	0,001	BZ53	5	8000	9,3
0,75 0,55*	HBZ 71C 4	1720	3,06	2,6	1,3	66	78,8	K	4	4,1	6,3	0,0014	BZ53	7,5	6300	11
1 0,75*	HBZ 71D 4	1680	4,23	3,8	1,9	65	77	J	3,4	3,5	4,8	0,0014	BZ53	7,5	5600	11
0,75 0,55	HBZ 80A 4	1740	3	2,4	1,2	74	78,4	L	3,3	3,7	7,2	0,0025	BZ04	11	6300	13
1 0,75	HBZ 80B 4	1720	4,14	3,4	1,7	70	78,5	K	3,2	3,5	6,2	0,0025	BZ04	11	5600	13
1,5 1,1*	HBZ 80C 4	1720	6,2	5	2,5	76	80	J	3,6	3,7	5,7	0,0033	BZ04	16	4000	15
1,5 1,1	HBZ 90S 4	1720	6,2	5,4	2,7	68	80	J	3	3,3	5,3	0,0025	BZ14	16	4000	17
2 1,5	HBZ 90L 4	1730	8,3	7	3,5	68	81,5	H	3,6	4,2	6	0,0037	BZ05	27	3150	22
2,4 1,85 *	HBZ 90LB 4	1710	10,4	8	4	70	84	J	3,6	4	5,6	0,004	BZ05	27	3150	23
3 2,2* <input type="checkbox"/>	HBZ 90LC 4	1700	12,6	10	5	70	84	J	3,3	3,8	5,4	0,0045	BZ05	40	2500	25
3 2,2	HBZ 100LA 4	1730	12,3	9,2	4,6	74	85,5	J	3,1	3,7	6,1	0,0054	BZ15	40	2500	26
4 3	HBZ 100LB 4	1730	16,4	12,2	6,1	73	85,5	K	3,2	3,7	6,6	0,0072	BZ15	40	2500	30
5,4 4	HBZ 112M 4	1740	22,1	16	8	72	85,5	J	3,4	3,9	6,5	0,0117	BZ06S	75	2000	39
7,5 5,5 * <input type="checkbox"/>	HBZ 112MC 4	1740	30,7	22,5	11,2	75	87,5	K	3,7	4,2	6,7	0,0139	BZ06S	75	1400	42
7,5 5,5	HBZ 132S 4	1750	30,5	21	10,6	74	87,5	K	3,7	3,9	7,5	0,0245	BZ56	75	1400	56
10 7,5	HBZ 132M 4	1750	40,7	27,5	13,7	77	87,5	K	3,9	4,1	7,8	0,033	BZ06	100	1000	65
12,4 9,2	HBZ 132MB 4	1760	51	35,4	17,7	75	87,5	K	4	4,4	8	0,0399	BZ07	150	850	72
15 11 <input type="checkbox"/>	HBZ 132MC 4	1760	61	41	20,5	76,4	89,5	K	4,2	4,7	8	0,0455	BZ07	150	710	78
15 11 <input type="checkbox"/>	HBZ 160SC 4	1760	61	41	20,5	76,4	89,5	K	4,2	4,7	8	0,0455	BZ07	150	710	87

Efficiency value not complying with IE3 class range (IEC 60034-30); nominal power and name plate referred to S3 70% intermittent duty.

1) The name plate contains data expressed in: hp, rpm, PF (power factor) in %.

2) For design with flywheel motor size-brake size pairings are stated at ch. 4.9 (23).

3) Other supply on request are available, see ch. 4.9.

* Power or motor power-to-size correspondence not according to standard.

Temperature rise class F.

Technical data 230.460V 60Hz

4 poles - 1800 min⁻¹

IP 55

IC 411

Insulation class F

Temperature rise class B

Service factor **SF 1,15**

9 terminals



Premium Efficiency (IE3)
230.460V - 60Hz²⁾
EISA
 ENERGY STAR US CC131B

In accordance with US DOE 10 CFR 431 and CSA C390 EISA ACT December 19, 2017

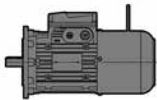

UT.C 1373

P _N		Motor	n _N	M _N	I _N		PF	NEMA Nom. Eff. MG1-12	NEMA Code	M _S /M _N	M _{max} /M _N	I _S /I _N	J ₀	Brake M _f	z ₀	kg
1)	1)				A	A										
hp	kW		RPM	N m	230 V	460 V	%	%								
1	0,75 *	HB3Z 90 S 4	1740	4,1	3	1,5	73	85,5	K	3,4	4,3	7,2	0,0034	BZ 14 11	3150	19,4
1,5	1,1 *	HB3Z 90 L 4	1740	6,1	4,2	2,1	75	86,5	K	3,4	4,1	7,7	0,0045	BZ 14 16	2500	22,4
2	1,5	HB3Z 90 LB 4	1740	8,3	5,8	2,9	75	86,5	L	3,4	4,4	7,9	0,0047	BZ 05 27	2500	24,5
3	2,2	HB3Z 112 MA 4	1760	12	8	4	78	89,5	M	3,9	5,1	9,6	0,0123	BZ 15 40	2000	37
4	3 *	HB3Z 112 M 4	1750	16,3	10,6	5,3	79	89,5	M	4,1	5,4	9,4	0,0133	BZ 15 40	1600	39
5,4	4 *	HB3Z 112 MB 4	1760	21,8	15	7,5	75	89,5	N	4,0	5,5	10,3	0,0149	BZ 06S 75	1400	44
7,5	5,5 *	HB3Z 132 M 4	1770	29,7	19	9,5	79	91,7	L	4,1	4,4	9,7	0,0367	BZ 56 75	710	69
10	7,5	HB3Z 132 MB 4	1760	40,6	25,8	12,9	79	91,7	L	3,7	4,4	9,1	0,0458	BZ 06 100	710	79,5
12,3	9,2	HB3Z 132 MC 4	1765	49,9	33,8	16,9	74	91,7	M	4,3	4,4	8,7	0,0458	BZ 07 150	710	79,5

1) The name plate contains data expressed in: hp, rpm, PF (power factor) in %.

2) On request other voltage are possible:

255.440V - 60Hz, 265.460V - 60 Hz and 277.480V - 60Hz.

440V (Δ) - 60 Hz, 460V (Δ) - 60 Hz and 480V (Δ) - 60 Hz.

* Power or motor power-to-size correspondence not according to standard.

4.7

Technical data 230.460V 60Hz

6 poles - 1200 min⁻¹

IP 55

IC 411

Insulation class F

Temperature rise class B

Service factor **SF 1,15**

9 terminals

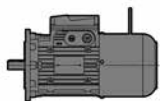

UT.C 1373

IE2 P_N 0,16 ... 0,75 hp
P_N ≥ 1 hp S3 70%
 ErP **US**
230.460V - 60Hz ³⁾
NEMA MG1-12

P _N	Motor	n _N	M _N	I _N		PF	NEMA Nom. Eff. MG1-12	NEMA Code	M _S /M _N	M _{max} /M _N	I _S /I _N	J ₀	Brake	M _f	z ₀		
				A 230 V	A 460 V												1)
1) hp kW		1) RPM	N m			1) %	%					kg m ²		N m			
0,12	0,09	HBZ 63 A 6	1120	0,76	0,88	0,44	52	52,5	J	2,9	3	2,7	0,0004	BZ 12	1,75	10000	5,9
0,16	0,12	HBZ 63 B 6	1120	1,02	1,04	0,52	53	55,8	J	3,1	3,2	2,9	0,0005	BZ 12	3,5	10000	6,3
0,20	0,15 *	HBZ 63 C 6	1100	1,3	1,2	0,6	56	58	J	3,1	3,2	3	0,0006	BZ 12	3,5	9500	6,9
0,25	0,18	HBZ 71 A 6	1120	1,53	1,22	0,61	60	62,6	H	3	3,1	3,6	0,001	BZ 53	5	9000	8,7
0,33	0,25	HBZ 71 B 6	1120	2,1	1,62	0,81	60	64,9	J	3,1	3,1	3,9	0,0013	BZ 53	5	9000	9,5
0,5	0,37 *	HBZ 71 C 6	1120	3,16	2,2	1,1	63	70,9	J	3,2	3,3	4,5	0,0018	BZ53	7,5	8000	11,1
0,5	0,37	HBZ 80 A 6	1130	3,12	2,2	1,1	61	68,4	J	3,3	3,5	4,3	0,0021	BZ 04	11	7500	12
0,75	0,55	HBZ 80 B 6	1140	4,6	3	1,5	62	75,7	K	3,6	3,7	5,3	0,0033	BZ 04	16	7100	15
1	0,75 *	HBZ 80 C 6	1130	6,3	4	2	62	75,5	J	2,9	3,1	4,6	0,0033	BZ 04	16	5600	15
1	0,75	HBZ 90 S 6	1130	6,3	3,8	1,9	66	75,5	H	2,8	3	4,5	0,0042	BZ 14	16	5600	17,5
1,5	1,1	HBZ 90 L 6	1130	9,4	5,6	2,8	67	75,5	H	3	3,2	4,7	0,0059	BZ 05	27	4250	23
2	1,5 * □	HBZ 90 LC 6	1120	12,7	7,6	3,8	64	77	J	3,1	3,3	5,2	0,0069	BZ 05	40	4000	25
2	1,5	HBZ 100 LA 6	1140	12,5	7	3,5	68	80	K	3,2	3,4	5,8	0,0099	BZ 15	40	2800	27
2,4	1,85 *	HBZ 100 LB 6	1140	15,6	8,6	4,3	68	80	K	3,4	3,6	6	0,0121	BZ 15	40	2500	30
3	2,2	HBZ 112 M 6	1150	18,6	9,4	4,7	72	82,5	J	2,4	2,9	6	0,0157	BZ 06S	50	2240	36
4	3 * □	HBZ 112 MC 6	1150	24,7	12,4	6,2	73	84	J	2,6	3,1	6,1	0,0197	BZ 06S	75	2000	41
4	3	HBZ 132 S 6	1160	24,5	13,8	6,9	64	85,5	K	2,6	3,4	6,1	0,0305	BZ 56	75	1900	53
5,4	4	HBZ 132 M 6	1160	33,1	17,2	8,6	70	85,5	K	2,9	3,4	6,9	0,0394	BZ 06	100	1120	60
7,5	5,5	HBZ 132 MB 6	1160	46	23	11,4	72	86,5	L	3	3,4	7,5	0,0509	BZ 07	150	1000	70
10	7,5 □	HBZ 132 MC 6	1150	62	31	15,5	70	86,5	K	2,7	3,2	6,9	0,0611	BZ 07	150	800	78
10	7,5 □	HBZ 160 SC 6	1150	62	31	15,5	70	86,5	K	2,7	3,2	6,9	0,0611	BZ 07	150	800	87

Efficiency value not complying with IE3 class range (IEC 60034-30); nominal power and name plate referred to S3 70% intermittent duty.

- 1) The name plate contains data expressed in: hp, rpm, PF (power factor) in %.
- 2) For design with flywheel motor size-brake size pairings are stated at ch. 4.9 (23).
- 3) Other supply on request are available, see ch. 4.9.
- * Power or motor power-to-size correspondence not according to standard.
-) Temperature rise class F.

Technical data 230.460V 60Hz

6 poles - 1200 min⁻¹

IP 55

IC 411

Insulation class F

Temperature rise class B

Service factor **SF 1,15**

9 terminals



Premium Efficiency (IE3)

230.460V - 60Hz²⁾

EISA



In accordance with US DOE 10 CFR 431 and CSA C390 EISA ACT December 19, 2017



UT.C 1373

P_N		Motor	n_N	M_N	I_N		PF	NEMA Nom. Eff. MG1-12	NEMA Code	M_S/M_N	M_{max}/M_N	I_S/I_N	J_0	Brake		z_0	kg
1)					1)									A	A		
hp	kW		RPM	N m	230 V	460 V	%	%				kg m ²	N m	starts/h			
1	0,75 *	HB3Z 100 LA 6	1160	6,1	3,2	1,6	71	82,5	M	2,9	4,4	7,9	0,0134	BZ 15 13	3200	32	
1,5	1,1 *	HB3Z 112 M 6	1160	9,1	4,4	2,2	73	87,5	J	2,5	3,4	6,3	0,0219	BZ 15 27	2500	40	
2	1,5 *	HB3Z 112 MB 6	1160	12,3	6,2	3,1	70	88,5	K	3,0	3,9	6,9	0,0219	BZ 15 40	2000	40	
3	2,2 *	HB3Z 132 S 6	1170	18	8,6	4,3	72	89,5	K	2,7	3,6	7,3	0,0367	BZ 06 50	1400	58	
4	3 *	HB3Z 132 M 6	1170	24,5	11,6	5,8	72	89,5	K	2,8	3,8	7,6	0,0471	BZ 56 75	1000	67	
5,4	4	HB3Z 132 MB 6	1170	32,6	15,8	7,9	70	89,5	L	3,1	4,1	8,0	0,061	BZ 06 100	800	78	

1) The name plate contains data expressed in: hp, rpm, PF (power factor) in %.

2) On request other voltage are possible:

255.440V - 60Hz, 265.460V - 60 Hz and 277.480V - 60Hz.

* Power or motor power-to-size correspondence not according to standard.

4.8

Technical data 380V 60Hz

4 poles - 1700 min⁻¹

IP 55

IC 411

Insulation class F

Temperature rise class B

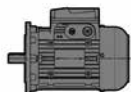

U.T.C. 1371

P _N	Motor	n _N	M _N	I _N	cos φ	η			M _S / M _N	M _{max} / M _N	I _S / I _N	J ₀	Brake	M _f	z ₀	kg
						IEC 60034-2-1										
kW		min ⁻¹	N m	A 380 V		100%	75%	50%				kg m ²		N m	avv./h	
0,75	HB3Z 80B 4	1730	4,1	2,2	0,62	83,5	83,8	81,1	3,7	3,8	6,1	0,002	BZ 04	11	5700	16
1,1	HB3Z 90S 4	1735	6,1	2,6	0,77	86,5	85,5	83,3	3,3	3,7	7,5	0,0043	BZ 14	16	2500	22,5
1,5	HB3Z 90L 4	1740	8,3	3,7	0,75	86,5	84,0	82,5	3,4	4,4	7,9	0,0047	BZ 05	27	2500	25
2,2	HB3Z 100LA 4	1750	12,0	5,2	0,73	89,5	87,7	85,3	4,1	4,6	8,2	0,008	BZ 15	40	2360	32
3 *	HB3Z 112MA 4	1760	16,3	6,5	0,77	89,5	89,5	87,5	4,1	4,9	9,2	0,013	BZ 15	40	1600	39
4	HB3Z 112M 4	1760	21,8	9,0	0,75	89,5	90,2	88,7	4,0	5,5	10,3	0,015	BZ 06S	75	1400	44
5,5	HB3Z 132S 4	1770	29,7	12,8	0,71	91,7	90,2	88,2	4,6	5,2	9,8	0,0367	BZ 56	75	710	69
7,5	HB3Z 132M 4	1765	40,5	16,0	0,77	91,7	90,9	89,4	4,7	4,9	10,0	0,0442	BZ 06	100	710	77
9,2 *	HB3Z 132MB 4	1765	49,8	20,5	0,73	92,4	91,8	90,6	4,3	4,4	8,7	0,047	BZ 07	150	710	80,5

* Power or motor power-to-size correspondence not according to standard.

Technical data 380V 60Hz

4 poles - 1700 min⁻¹
 IP 55
 IC 411
 Insulation class F
 Temperature rise class B

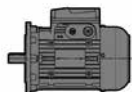

UT.C. 1371

P _N kW	Motor		n _N min ⁻¹	M _N N m	I _N A 380 V	cos φ	η IEC 60034-2-1			M _s / M _N	M _{max} / M _N	I _s / I _N	J ₀ kg m ²	Brake	Mf N m	z ₀ avv./h	
							100%	75%	50%								
0,75 *	HB3Z	100LA 6	1160	6,1	1,9	0,71	82,5	84,2	80,9	2,9	4,4	7,9	0,013	BZ 15	13	3200	32
1,1 *	HB3Z	112M 6	1160	9,1	2,6	0,73	87,5	88,2	86,8	2,5	3,4	6,3	0,0215	BZ 15	27	2500	40
1,5 *	HB3Z	112MB 6	1160	12,3	3,7	0,70	88,5	88,2	86,5	3,0	3,9	6,9	0,0215	BZ 15	40	2000	40
2,2 *	HB3Z	132S 6	1170	18,0	5,2	0,72	89,5	89,9	88,4	2,7	3,6	7,3	0,0358	BZ 06	50	1400	58
3 *	HB3Z	132M 6	1170	24,5	7,0	0,72	89,5	90,2	88,7	2,8	3,8	7,6	0,0461	BZ 56	75	1000	67
4	HB3Z	132MB 6	1170	32,6	9,5	0,70	89,5	91	89,5	3,1	4,1	8,0	0,06	BZ 06	100	800	78

* Power or motor power-to-size correspondence not according to standard.

4.9

Motor dimensions

Mounting position

I+M B5, IM B5R, IM B5...

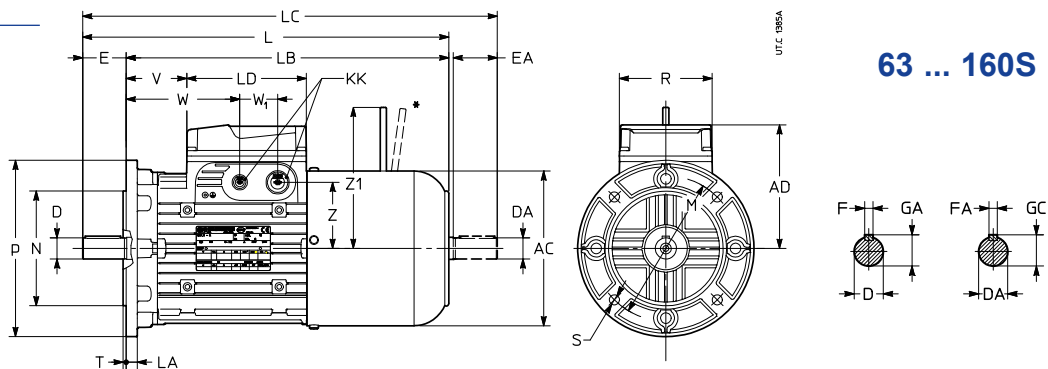

63 ... 160S

* On request

Motor size	AC	AD	L	LB	LC	LD	KK	R	V	W	W ₁	Z	Z ₁	Shaft end				Flange									
														D	1)	E	F	GA	M	N	P	LA	S	T			
	∅						2)							∅		h ₉	∅	∅	∅	∅							
63	B5R	123	95	281	261	306	103	4×M16	86	46	86	36	45	96	9	j6	M3	20	3	10,2	100	80	j6	120	8	7	3
	B5A			284	312					29	69				11	j6	M4	23	4	12,5	115	95	j6	140	10	9	3
	B5			267	244										295	11 ³⁾	j6	M4	23 ³⁾	130	110	j6	160			3,5	
BX1																											
71	B5B	138	112	320	297	349	2×M16 + 2×M20	66	106	47	87	62	103	11	j6	M4	23				100	80	j6	120	8	7	3
	B5R			327	363									115	95	j6	140	10	9	3							
	B5A			308	278									344	115	95	j6	140	10	9							
	B5			301	330									130	110	j6	160			3,5							
	BX2			301	330									165	130	j6	200	12	11								
	BX1			308	344									165	130	j6	200	12	11								
80	B5B	156	121	353	323	390	2×M16 + 2×M25	80	120	59	99	71	129	14	j6	M5	30			115	95	j6	140	10	9	3	
	B5R			363	410									130	110	j6	160			3,5							
	B5A			342	302									389	165	130	j6	200	12	11							
	B5			332	365									369	165	130	j6	200	12	11							
BX2																											
90 S ⁵⁾	B5S	176	141	387	357	424	2×M16 + 2×M25	106	60	120	43	75	75	14	j6	M5	30			130	110	j6	160	10	9		
	B5B			397	444									19	j6	M6	40	6	21,5	165	130	j6	200	12	11		
	B5R			376	336									423	24	j6	M8	50	8	27							
	B5			386	443																						
90 L	B5S	176	141	417	387	454	2×M16 + 2×M25	106	60	120	43	75	160 ⁴⁾	14	j6	M5	30	5	16	130	110	j6	160	10	9		
	B5B			427	474									19	j6	M6	40	6	21,5	165	130	j6	200	12	11		
	B5R			406	366									453	24	j6	M8	50	8	27							
	B5			416	473																						
100	B5C	194	151	472	432	520	2×M16 + 2×M25	106	60	120	43	75	86	19	j6	M6	40	6	21,5	130	110	j6	160	10	9		
	B5S			482	540									165	130	j6	200	12	11								
	B5R			492	560									215	180	j6	250	14	14	4							
	B5A			465	405									533													
B5																											
112	B5S	218	163	501	461	550	2×M16 + 2×M25	148	113	201	55	109	203 ⁴⁾	19	j6	M6	40	6	21,5	165	130	j6	200	12	11	3,5	
	B5R			511	570									24	j6	M8	50	8	27	215	180	j6	250	14	14	4	
	B5A			521	590									28	j6	M10	60	31									
	B5			495	435									564													
132 S, M ⁶⁾	B5S	257	194	578	528	637	2×M16 + 2×M32	148	113	201	55	109	203 ⁴⁾	24	j6	M8	50		27	165	130	j6	200	12	11	3,5	
	B5B			588	657									28	j6	M10	60	31	215	180	j6	250	14	14	4		
	B5R			608	697									38	k6	M12	80	10	41	265	230	j6	300				
	B5A			573	493									662													
B5																											
132 MA ⁸⁾ ... MCB5S	B5S	257	194	638	588	697	2×M16 + 2×M32	148	113	201	55	109	226 ⁴⁾	24	j6	M8	50	8	27	165	130	j6	200	12	11	3,5	
	B5B			648	717									28	j6	M10	60	31	215	180	j6	250	14	14	4		
	B5R			668	757									38	k6	M12	80	10	41	265	230	j6	300				
	B5A			633	553									722													
B5																											
160 S	B5			682	572	771								42	k6	M16 ⁷⁾	110 ⁷⁾	12 ⁷⁾	45 ⁷⁾	300	250	h6	350	15	18	5	

1) Tapped butt-end hole.

2) Prearranged for cable entry knockout openings on both sides (two openings on each side).

3) Shaft end not according to standard.

4) Dimension valid for motor-brake pairing: 90-BZ05, 112-BZ06S, 132-BZ56 and 160-BZ07; with brake of smaller size see Z₁ of smaller motor size.

5) For motor HB3Z 90S2 e HB3Z 90S 4 dimensions are the ones as size 90L.

6) For motor HB3Z 132SB 2, HB3Z 132SC 2, HB3Z 132S 4, HB3Z 132M 4 and HB3Z 132M 6 dimensions are the ones as size 132 MA ... MC.

7) Second shaft end dimensions as size 132.

8) For motor HBZ 132MA 2 dimensions are the ones of size 132S, M.

Mounting position
IM B14, IM B14R

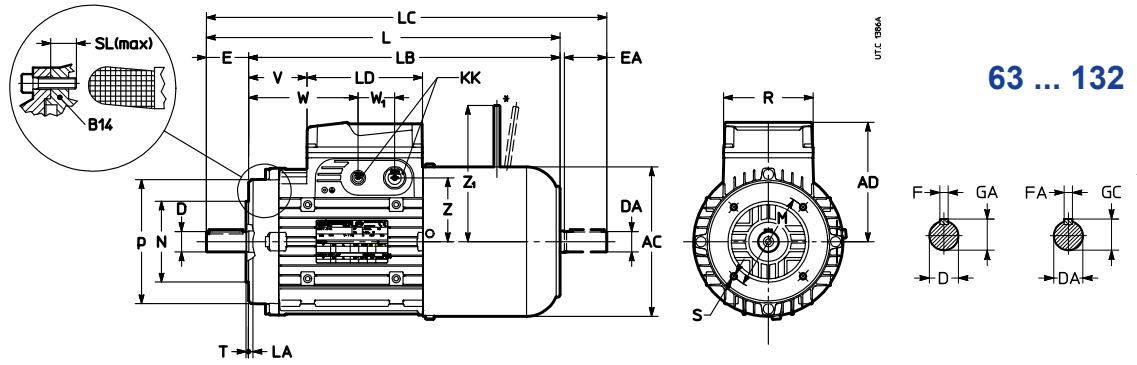

63 ... 132

* On request

Motor size	AC	AD	L	LB	LC	LD	KK	R	V	W	W ₁	Z	Z ₁	Shaft end				Flange								
														D DA	¹⁾	E EA	F FA	GA GC	M	N	P	LA	S	SL	T	
	∅						²⁾							∅	h9	∅	∅	∅	∅	∅	max					
63	B14	123	95	267	244	295	103	4×M16	86	29	69	36	45	96	11 j6 M4	23	4	12,5	75	60	j6	90	8	M5	10	2,5
71	B14R	138	112	301	278	330	2×M16 + 2×M20		47	87			62	103	14 j6 M5	30	5	16	85	70	j6	105	8	M6		
	B14			308	344																					
80	B14R	156	121	332	302	369			59	120			71	129	19 j6 M6	40	6	21,5	100	80	j6	120	8	M6		3
	B14			342	389																					
90 S⁸⁾	B14	176	141	386	336	443	2×M16 + 2×M25	106	39	99	43	75	160 ⁴⁾	24 j6 M8	50	8	27	115	95	j6	140	10	M8	12		
90 L	B14			416	366	473																				
100	B14	194	151	465	405	533			82	142			86	28 j6 M10	60	8	31	130	110	j6	160	10	M8	13	3,5	
112	B14	218	163	495	435	564			100	160			98	198 ⁴⁾												
132 S, M⁹⁾	B14	257	194	573	493	662	2×M16 + 2×M32	148	78	166	55	109	203 ⁴⁾	38 k6 M12	80	10	41	165	130	j6	200	18	M10	18		
132 MA¹⁰⁾ ... MC B14	B14			633	553	722																				

- 1) Tapped butt-end hole.
- 2) Prearranged cable entry knockout openings on both sides (two openings on each side).
- 4) Dimension valid for motor-brake pairing: 90-BZ05, 112-BZ06S, 132-BZ56 and 160-BZ07; with brake of smaller size see Z, of smaller motor size.
- 8) For motors **HB3Z 90S2** and **HB3Z 90S 4** dimensions are the ones of sizes 90L.
- 9) For motor **HB3Z 132SB 2**, **HB3Z 132SC 2**, **HB3Z 132S 4**, **HB3Z 132M 4** and **HB3Z 132M 6** dimensions are the ones of sizes 132 MA ... MC.
- 10) For motor **HBZ 132MA 2** dimensions are the same of size 132S, M.

Mounting position IM B3

63 ... 160S

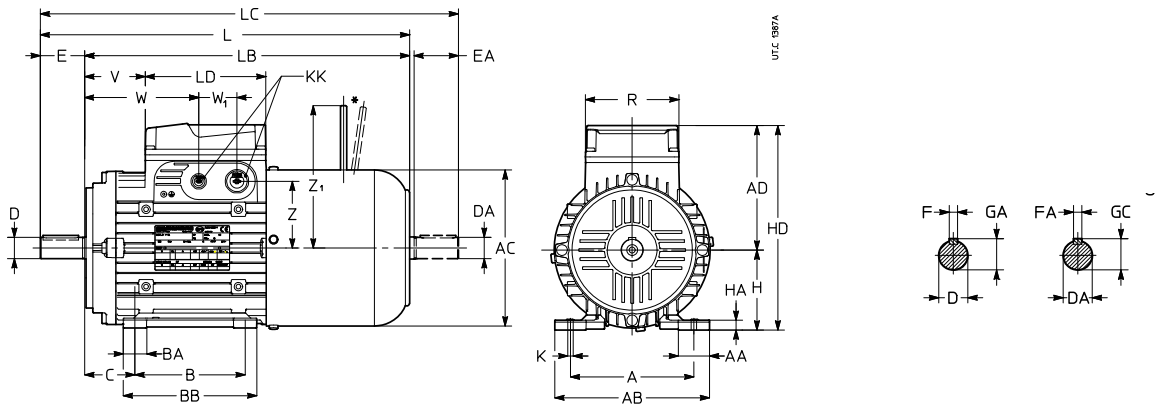

* On request

Motor size	AC	AD	L	LB	LCD	KK	R	V	W	W ₁	Y	Z	Z ₁	Shaft end				Feet														
														D	1)	E	F	GA	A	AB	B	C	BB	BA	AA	K	HA	H ⁷⁾	HD			
	∅					2)	R ₁					∅		EA	FA	GC																
63	B3	123	95	267	244	295	103	4×M16	86	29	69	36	-	45	96	11 j6	M4	23	4	12,5	100	120	80	40	100	21	27	7	9	63	158	
71	B3	138	112	308	278	344		2×M16 + 2×M20	-	47	87			62	103	14 j6	M5	30	5	16	112	138	90	45	110	22	28		10	71	183	
80	B3	156	121	342	302	389		2×M16 + 2×M20		59	99			71	129	19 j6	M6	40	6	21,5	125	152	100	50	125	26		9		80	201	
90 S⁸⁾	B3	176	141	386	336	443	136	2×M16 + 2×M25	106	39	99	43		75		24 j6	M8	50	8	27	140	174		56			35	11	90	230		
90 L	B3			416	366	473		2×M16 + 2×M25		69	129			160 ⁴⁾									125	150								
100	B3	194	151	465	405	533		2×M16 + 2×M32		82	142			86		28 j6	M10	60	8	31	160	196	140	63	185	40	37	12	12	100	251	
112	B3	218	163	495	435	564		2×M16 + 2×M32		100	160			98	198 ⁴⁾								190	226		70		50	15	112	275	
132 S, M⁹⁾	B3	257	194	573	493	662	190	2×M16 + 2×M32	148	78	166	55	-	109	203 ⁴⁾	38 k6	M12	80	10	41	216	257	140 ³⁾	89	210	42	52	14	17	132	326	
132 MA¹⁰⁾... MC	B3			633	553	722		2×M16 + 2×M32		138	226			226 ⁴⁾									178 ³⁾									
160 S	B3			682	572	771		2×M16 + 2×M32		157	245				42 k6	M16 ⁵⁾	110 ⁵⁾	12 ⁵⁾	45 ⁵⁾	254	294	210	108	246	45			20	160	354		

1) Tapped butt-end hole.

2) Sizes ≤ 132: prearranged cable entry knockout openings on both sides (two openings on each side).

3) Foot of 132S also has a centre distance of 178 mm and the one of size 132MA ... MC has also a centre distance of 140 mm.

4) Dimension valid for motor-brake pairing: 90-BZ05, 112-BZ06S, 132-BZ56 and 160-BZ07; with brake of smaller size see Z₁ of smaller motor size.

5) For size 160S the dimensions of second shaft end are the same of sizes 132.

7) Tolerance $\begin{matrix} 0 \\ -0.4 \end{matrix}$.

8) For motors **HB3Z 90S2** and **HB3Z 90S 4** dimensions are the ones of sizes 90L.

9) For motor **HB3Z 132SB 2**, **HB3Z 132SC 2**, **HB3Z 132S 4**, **HB3Z 132M 4** and **HB3Z 132M 6** dimensions are the ones of sizes 132 MA ... MC.

10) For motor **HBZ 132MA 2** dimensions are the same of size 132S, M.

Non-standard designs and accessories

Ref.	Description	Non-standard design code
(1)	Non-standard motor supply	–
(3)	Insulation class H	,H
(7)	Design for low temperatures (-30 °C)	,BT
(8)	Condensate drain holes	,CD
(9)	Additional winding impregnation	,SP
(13)	Anti-condensation heater	,S
(14)	Terminal box on one side (IM B3 and derivatives, 90 ... 160S)	,P...
(16)	Second shaft end	,AA
(17)	Axial independent cooling fan	,V...
(18)	Axial independent cooling fan and encoder	,V... ,E
(19)	Thermistor type thermal probes (PTC)	,T15
(20)	Bi-metal type thermal probes	,B15
(21)	Drip-proof cover	,PP
(23)	Flywheel	,W
(25)	Lever for manual release with automatic return	,L
(26)	Separate d.c. brake supply	see 4.9 (26)
(35)	Light alloy fan	,VL
(36)	Encoder	,E1... ,E5
(42)	Motor certified to UL	,UL
(47)	Design for damp and corrosive environment, stainless steel brake disc, bolts and screws	,UC
(48)	IP 56 protection	,IP 56
(49)	IP 65 protection	,IP 65
(53)	Brake with microswitch	,SB ,SU
(54)	Brake with ready air-gap reset	,RF
(61)	Manual rotation	,MM
(62)	Motor prearranged for encoder	,PE
(63)	Axial independent cooling fan and prearranged for encoder	,V... ,PE

(1) Non-standard motor supply

The first two columns show the possible types of supply.

Supply values, brake rectifier and independent cooling fan are **co-ordinated** with motor winding voltage as stated in the table.

Motor wound and stated for		Rectifier DIRECTLY connected to motor terminal box (center phase star)				Motor type		
V	Hz	Brake size 12, 53, 13, 04, 14	Brake size 05, 15, 06S, 56, 06, 07	Rectifier supply [V]	Coil voltage [Vdc]	HBZ	HB2Z	HB3Z
		Rectifier						
Δ220 Y380	50	RM1	RM2	220	103	○	●	●
Δ230 Y400	50	RM1	RM2	230	103	●	●	●
Δ265 Y460	60	RM1	RM2	265	103	●	●	●
Δ277 Y480	60	RM1	RM2	277	103	○	●	●
Δ240 Y415	50	RM1	RM2	240	103	○	●	●
YY230 Y460	60	RM1	RM2	350	103	○	○	○
Δ400	50	RM1	RM2	400	103	○	○	○
Δ480	60	≤80 RN1 ≥90 RR8	RR8	480	206	○	○	○
Δ255 Y440	60	RM1	RM2	255	103	○	○	○
Δ415	50	RM1	RM2	415	103	○	○	○
Δ440	60	RM1	RM2	440	103	○	○	○
Δ460	60	≤80 RN1 ≥90 RR8	RR8	460	206	○	○	○
Δ220 Y380	60	RM1	RM2	220	103	○	○	○
Δ380	60	RM1	RM2	380	103	○	○	○
Δ290 Y500	50	RM1	RM2	290	103	○	○	○
Δ346 Y600	60	RM1	RM2	346	103	○	○	○

● standard ○ on request

For different voltage values consult us.

Designation: by following instructions at ch. 4.2, state **voltage** and **frequency** (in the first table columns).

(3) Insulation class H

Insulation materials in class H with permissible temperature rise in class H.

Non-standard design code for the **designation: ,H**

(7) Design for low temperatures (-30 °C)

Standard motors can operate for possible ambient temperature down to -15 °C.

For ambient temperature down to -30 °C: special bearings, light alloy fan (in addition, cable glands and metal plugs, if foreseen in the conditions of supply).

If there are dangers of condensate, it is advisable to require also «Design for damp and corrosive environments» (47) and, if necessary, the design «Condensate drain holes» (8) and/or «Anti-condensation heater» (13).

May there be dangers of ice on friction surface consult us.

With designs (17), (18), (36) and (63), consult us.







Non-standard design code for the **designation: ,BT**

(8) Condensate drain holes

It is advisable for motors operating in particularly damp environments and/or with wide variation in the temperature and/or at low temperature. In motor designation state in «MOUNTING POSITION» the designation of the real application mounting position, determining the hole position.

Motors are supplied with closed holes.

Non-standard design code for the **designation: ,CD**

Mounting position						
IM						
B3	IM 1001	IM 1011	IM 1031	IM 1051	IM 1061	IM 1071
B5	IM 3001	IM 3011	IM 3031	IM 3051	IM 3061	IM 3071
B14	IM 3601	IM 3611	IM 3631	IM 3651	IM 3661	IM 3671
B3-B5	IM 2001	IM 2011	IM 2031	IM 2051	IM 2061	IM 2071
B3-B14	IM 2101	IM 2111	IM 2131	IM 2161	IM 2161	IM 2171
B3 ,AA	IM 1002	IM 1012	IM 1032	IM 1052	IM 1062	IM 1072
B5 ,AA	IM 3002	IM 3012	IM 3032	IM 3052	IM 3062	IM 3072
B14 ,AA	IM 3602	IM 3612	IM 3632	IM 3652	IM 3662	IM 3672

(9) Additional winding impregnation

It consists of a second impregnation cycle after stator winding assembly (standard with designs (47), (48)).

Useful where it is necessary to have an additional protection (of the windings) against electrical stress (voltage peaks due to rapid commutations or to «low quality» inverters with high voltage gradients) or mechanical agents (mechanical or electromagnetic vibrations: e.g. from inverter). See also ch. 2.9 «Running with inverter».

Non-standard design code for the **designation: ,SP**

(13) Anti-condensation heater

It is advisable for motors operating in particularly damp environments and/or with wide variation in the temperature and/or at low temperature; single-phase supply 230 V a.c. $\pm 10\%$ 50 or 60 Hz (other voltage on request); power absorbed: 15 W for sizes 63 and 71, 25W for sizes 80 ... 100, 50W for sizes 112 ... 160.

Heater must not be connected during the running.

Non-standard design code for the **designation: ,S**

(14) Terminal box on one side for IM B3 and derivatives (sizes 90 ... 160S)

Terminal box in position P1 or P2.

Non-standard design code for the **designation:**

,P... (additional code 1 or 2 according to scheme beside).

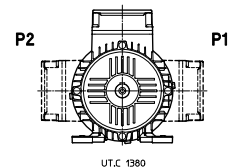

(16) Second shaft end

For dimensions see ch 4.8; radial loads are not permissible.

Not possible with designs (17), (18) and with design (36), (62) e (63)

Non-standard design code for the **designation: ,A**

(17) Axial independent cooling fan

Cooling provided with **compact** axial independent cooling fan, for variable speed drives (motor may absorb nominal current for all speed range, in continuous duty cycle and without overheating) with inverter and/or for heavy starting cycles (for z_0 increases consult us).

LB dimension (see ch. 4.8) **increases** by the ΔLB quantity stated in the following table.

Specifications of independent cooling fan:

- 2 poles motor;
- **IP 54** protection (it is the protection stated on name plate);
- supply terminals on relevant auxiliary terminal block located inside the motor terminal box;
- other data according to the following table.

Not possible with «Flywheel» design (23).

Non-standard design code for the **designation: ,VA ,VD ,VF.**

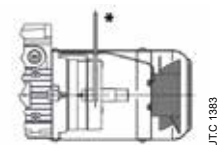

63 ... 160S

Motor size wound and stated for			Independent cooling fan name plate				Independent cooling					
Motor size	V	Hz	V	Hz	W	A	kg	Code	Type	ΔLB		
63 ... 80	Δ220 Y380	50	230	50/60	19/18	0,12/0,11	0,4	,VA	Single phase	81 (Size 63)	68 (Size 71)	73 (Size 80)
	Δ230 Y400	50										
	Δ265 Y460	60										
	Δ277 Y480	60										
	Δ240 Y415	50										
	YY230 Y460	60										
	Δ400	50										
	Δ480	60										
	Δ255 Y440	60										
	Δ415	50										
	Δ440	60										
	Δ460	60										
	Δ220 Y380	60										
	Δ380	60										
	Δ290 Y500	50										
	Δ346 Y600	60										
90	Δ220 Y380	50	230	50/60	45/39	0,31/0,25	0,9	,VA	Single phase	88		
	Δ230 Y400	50										
	Δ265 Y460	60										
	Δ277 Y480	60										
	Δ240 Y415	50										
	YY230 Y460	60										
	Δ400	50										
	Δ480	60										
	Δ255 Y440	60										
	Δ415	50										
	Δ440	60										
	Δ460	60										
	Δ220 Y380	60										
	Δ380	60										
	Δ290 Y500	50										
	Δ346 Y600	60										
100,112	Δ220 Y380	50	Y380	50	40	0,12	1,3	,VD	Three phase	78		
	Δ230 Y400	50	Y400	50	45	0,13						
	Δ265 Y460	60	Y460	60	65	0,14						
	Δ277 Y480	60	Y480	60	50	0,15						
	Δ240 Y415	50	Y415	50	45	0,13						
	YY230 Y460	60	Y460	60	45	0,13						
	Δ400	50	Y400	50	45	0,13						
	Δ480	60	Y480	60	50	0,15						
	Δ255 Y440	60	Y440	60	43	0,12						
	Δ415	50	Y415	50	45	0,13						
	Δ440	60	Y440	60	43	0,12						
	Δ460	60	Y460	60	45	0,13						
	Δ220 Y380	60	Y380	60	38	0,11						
	Δ380	60	Y380	60	38	0,11						
	Δ290 Y500	50	Y500	50	45	0,1						
132,160S	Δ220 Y380	50	Y380	50	50	0,13	1,7	,VD	Three phase	81		
	Δ230 Y400	50	Y400	50	53	0,15						
	Δ265 Y460	60	Y460	60	65	0,14						
	Δ277 Y480	60	Y480	60	70	0,15						
	Δ240 Y415	50	Y415	50	51	0,16						
	YY230 Y460	60	Y460	60	65	0,14						
	Δ400	50	Y400	50	53	0,15						
	Δ480	60	Y480	60	70	0,15						
	Δ255 Y440	60	Y440	60	60	0,14						
	Δ415	50	Y415	50	51	0,16						
	Δ440	60	Y440	60	60	0,14						
	Δ460	60	Y460	60	65	0,14						
	Δ220 Y380	60	Y380	60	56	0,12						
	Δ380	60	Y380	60	56	0,12						
	Δ290 Y500	50	Y500	50	53	0,12						

IC 416 is stated on name plate.

(18) Axial independent cooling fan and encoder

Independently cooled motor equipped with hollow shaft encoder with elastic fastening for brake air-gap adjustment. For specifications and designation code relevant to the independent cooling fan and the encoder see designs (17) and (36), respectively.

Not possible with «Flywheel» design (23).

Non-standard design code for the **designation**: ,V ... ,E ...

IC 416 is stated on name plate

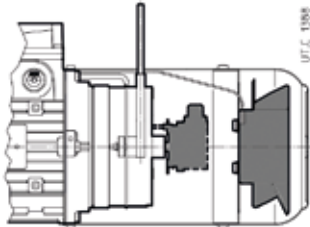

Motor size	ΔLB [mm]
	Encoder ,E1 ... ,E5
63	81
71	68
80	73
90	88
100	78
112	78
132	81
160S	81

(19) Thermistor type thermal probes (PTC)

Three thermistors wired in series (to DIN 44081/44082), inserted in the windings, for connection to a suitable contact breaker device. A sharp variation in resistance occurs when (delay 10 ÷ 30 s) the temperature of the windings reaches the setting temperature of **150 °C** (T15).

With design (3) «Insulation class H» if required **thermistor** with setting temperature of 170 °C (**T17**) are supplied.

Terminals connected to a loose or fixed terminal block inside the terminal box.

Non-standard design code for the **designation**: ,T15

(20) Bi-metal type thermal probes

Three bi-metal probes wired in series with usually closed contact inserted in the windings. Nominal current 1,6 A, nominal voltage 250 V a.c.. The contact opens when (delay 20 ÷ 60 s) the temperature of the windings reaches the setting temperature of **150 °C** (B15).

With design (3) «Insulation class H» if required, **bi-metal probes** with setting temperature of 170 °C (**B17**) are supplied.

Terminals connected to a loose or fixed terminal block inside the terminal box.

Non-standard design code for the **designation**: ,B15

(21) Drip-proof cover

Necessary design for outdoor applications or when water sprays are present, in mounting position with downwards vertical shaft (IM V5, IM V1, IM V18).

LB dimension (see. ch. 4.8) increases by ΔLB stated in table:

Non-standard design code for the **designation**: ,PP

Motor size	ΔLB [mm]
63 ... 160S	25

(23) Flywheel (motor for traverse movements with progressive start and stop)

63 ... 160S motors, **2** poles motors are usually envisaged in design for traverse movements which further increases the high start and stop progressivity **typical** of **HBZ** brake motor; this design allows to avoid – in an economic and reliable way – problems of jerky operations, slips, excessive stress and oscillation of overhung loads. Usually consider motor power for duty **S3** (however the motor name plate shows S1 duty).

Progressive start is obtained by the appropriate «torque-speed» characteristics and by prolonging the starting time increasing the motor moment of inertia J_0 by addition of a **flywheel** absorbing energy during starting phase and returning it during braking phase. Flywheel mass and its additional moment of inertia are stated in the table; mentioned values are to be added to mass value and J_0 .

Progressive stop is obtained as a result of the greater kinetic energy motor has (due to increased moment of inertia) which prolongs the stopping time, and of the braking torque always proportioned to motor torque (with the possibility to be decreased when necessary).

Motors are designed to withstand long starting times ($2 \div 4$ s) that progressive start entails.

For the calculation of frequency of starting see point 2.6; in the formula consider $(J + J_v)$ instead of J .

With this design, motor-brake size pairings are always:

63, 71-BZ12 with $M_{f \max} = 3,5$ Nm,

80-BZ13 with $M_{f \max} = 7,5$ Nm,

90-BZ14 with $M_{f \max} = 16$ Nm,

100, 112-BZ15 with $M_{f \max} = 40$ Nm,

132S-BZ56 with $M_{f \max} = 75$ Nm,

132M-160S BZ06 with $M_{f \max} = 100$ Nm.

There are no variations in overall dimensions.

Design not possible with designs (17), (18), (36), (53), (62), (63) and HB3Z Premium Efficiency EISA motors

Non-standard design code for the **designation: ,W.**

Motor size	Design W	
	flywheel mass kg	J_v kg m ²
63	0,63	0,0006
71	1,17	0,0013
80	1,89	0,0033
90	2,67	0,0056
100	3,6	0,0086
112	4,8	0,0134
132, 160S	6,8	0,028

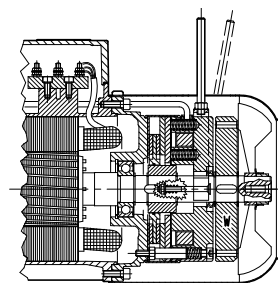

(25) Lever for manual release with automatic return

Three-phase motors equipped with lever for manual release with automatic return and removable lever rod; position of release lever corresponding to terminal box as per schemes.

Non-standard design codes for the **designation**: ,L ,L1 (90°) ,L2 (270°) ,L3 (180°).

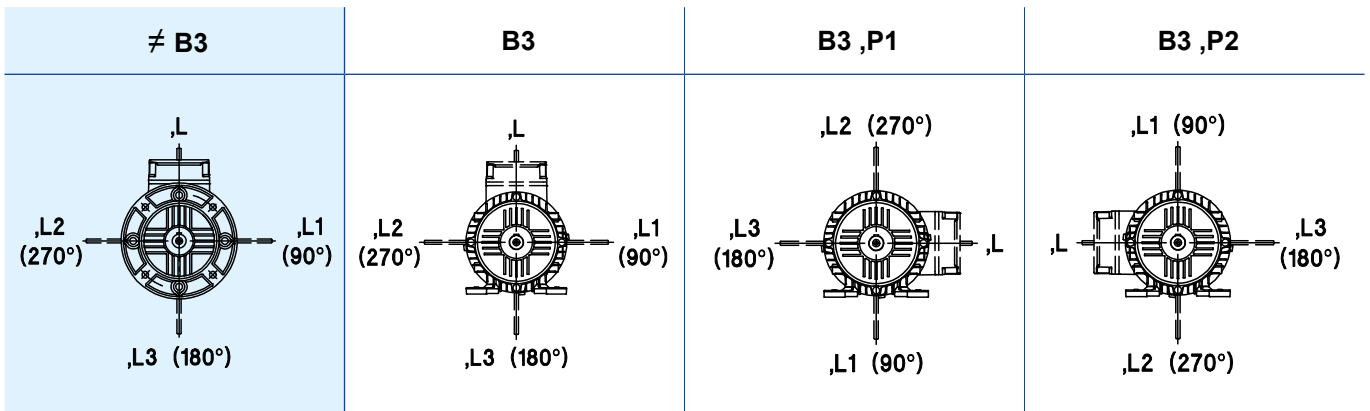

(26) Separate d.c. brake supply

Motors are supplied as standard according to ch. 4.9 (1):

Rectifier connected directly to motor terminal block.

Brake separate supply is necessary in several applications (e.g.: motors driven by inverter, motors for lifting with on-load descent braking). Following rectifier input voltages are available on request.

For the **designation** use the non-standard design codes stated in the table.

Brake size	Rectifier supply V~	Name plate data		
		Rectifier	Nominal brake coil voltage V c.c. ± 5%	Code
12, 53, 13, 04, 14	24 V c.c.–d.c. ¹⁾	-	24	,F17
	110 ... 440	RM1	103	,F1A
	460 ... 480	≤ 80 RN1 / ≥ 90 RR8	206	,F12A
05, 15	24 V c.c.–d.c. ¹⁾	-	24	,F17
	110 ... 440	RM2	103	,F1A
	460 ... 480	RR8	206	,F12A
06S, 56, 06, 07	24 V c.c.–d.c. ¹⁾	-	24	,F17
	110	RR5	51	,F15
	200 ... 440	RM2	103	,F1B
	460 ... 480	RR8	206	,F12A

1) Rectifier is not supplied.

(35) Light alloy fan

Motor with light alloy fan (aluminum) for environments where it is not advisable to use the standard plastic fan.

Non-standard design code for the **designation**: ,VL

(36) Encoder

Motor equipped with incremental hollow shaft encoder and elastic fastening with the following features stated in the table (free connection wirings for the use of connectors installed by the Buyer).

Not possible with design «Flywheel» (23).

For different and/or additional technical specifications, consult us.

LB dimension (see ch. 4.8) **increases** by ΔLB quantity stated in the table.

Size	Encoder ΔLB [mm] ,E1 ... ,E5
63	54
71	55
80	60
90	56
100	44
112	50
132, 160S	42

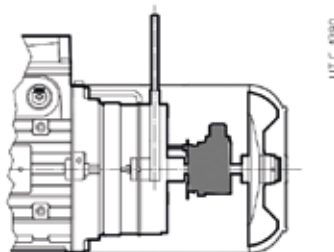

Output signal ¹⁾	RS 422 LD TTL	RS 422 TTL	Push - Pull HTL LD HTL	sin / cos	
Supply voltage U_B	5 V d.c. \pm 5%	10 \div 30 V d.c.		5 V d.c. \pm 5%	10 \div 30 V d.c.
Maximum current consumption (without load) I_N	90 mA		100 mA	110 mA	
Channels	A+, A-, B+, B-, 0+, 0-				
Output amplitude per track	$U_l \leq 0,5 V_{dc}$; $U_h \geq 2,5 V_{dc}$		$U_l \leq 0,5 V_{dc}$; $U_h \geq U_B - 1 V_{dc}$	1 $V_{PP} \pm 20\%$ (channel A, B) 0,1 \div 1,2 V (channel 0)	
Maximum output current per track I_{out}	± 20 mA		± 30 mA	-	
Maximum pulse frequency f_{max}	100 \div 300 kHz ^{2) 3)}			-	
Frequency -3 dB	-			≥ 180 kHz	
No. pulse per revolution	1024 ⁴⁾				
Vibration resistance (DIN-IEC 68-2-6)	≤ 100 m/s ² , 10 ... 2 000 Hz				
Shock resistance (DIN-IEC 68-2-27)	$\leq 1000 \div 2500$ m/s ² , 6 ms ²⁾			≤ 2000 m/s ² , 6 ms	
Maximum speed	6000 min ⁻¹				
Ambient temperature	-40 °C \div 100 °C	-30 °C \div 85 °C	-40 °C \div 100 °C	-25 °C \div 85 °C	
Protection degree (EN 60 529)	IP65				
Connections	free cables ⁸⁾ L = 1000 mm for use of connector installed by the user				
Encoder cable cross-sections	2x0,22+6x0,14 [mm ²]	10x0,14 [mm ²]	2x0,22+6x0,14 [mm ²]	8x0,22 [mm ²]	8x0,22 [mm ²]
Code for designation	,E1	,E2	,E3	,E4	,E5

1) Other electronic configurations available on request; consult Rossi S.p.A.

2) Variable depending on the model.

3) Parameter to be checked depending on the combination max motor speed/pulse per revolution required.

4) Other pulse rates available on request (max 5000 ppr).

8) On request: different cable lengths, output with connector or with connector and cable; consult us.

Non-standard design code for the **designation**: ,E1 ... ,E5 (see table).

(42) Motor certified to UL

Motor sizes 63 ... 160S certified (≤ 750 V, 50/60 Hz) both to UL1004-1 and CAN/CSA 22.2 No.100-14, for USA and Canada markets respectively, and electrically complying with NEMA Standard Publication MG 1-12 2009.

The main variations of this product are:

- approved UL class F insulation winding system;
- approved UL terminal block terminal assignment according to NEMA;
- cooling fan made of aluminium or certified thermoplastic material;
- certified and marked cables;
- verification and adjustment of air distances toward ground and between live parts;
- name plate with logo , showing only the data relating to the supply required in the order.
- for motor with $P_N \geq 1$ hp (motor with EISA Premium Efficiency class excluded) are available with intermittent duty cycle S3 70%.

Standard for 230YY 460Y V, 60 Hz motor supply and for motor with efficiency EISA Premium Efficiency class.

Non-standard design code for the **designation**: ,UL.

(47) Design for damp and corrosive environment

Advised for outdoor installation, in presence of humidity, in case of condensate dangers, especially for aggressive environment, includes design «Additional winding impregnation» (9) and anti-oxidation paint of stator, rotor and shaft.

Brake with dragging hub and brake plate (endshield end) made of stainless steel.

In these cases it is recommended to require also the design «Condensate drain holes» (8) and/or «Anti-condensation heater» (13).

For strongly aggressive environment (e.g. sea), it is possible to require also: stainless steel brake disc and anti-sticking friction surface²⁾; stainless steel bolts and screws of brake (fastening screws, bushes and nuts). In this case the motor is to be specifically purchased with «**Stainless steel brake disc, bolts and screws**»¹⁾.

With «Axial independent cooling fan and encoder» (18) and «Encoder» (36) consult us.

Non-standard design code for the **designation**: ,UC

1) Additional non-standard design code «Stainless steel brake disc, bolts and screws» for the **designation**: , DB

2) The braking torque is equal to 0,8 times the one stated in the point 4.5 .

(48) IP 56 protection

It is recommended for motors running in presence of direct splash or bolts of water (includes design (47) and seal between couplings surfaces of housing and endshields (to be re-adjusted when disassembling the motor).

Brake including: dragging hub and stainless steel brake plate (endshield side).

In these cases it is advisable to require also the design «Condensate drain holes» (8) and/or «Anti-condensation heater» (13) and «Stainless steel brake disc, bolts and screws».

Non-standard design code for the **designation**: ,IP 56

Non-standard design	63 ... 160S	
(17)	<input type="radio"/>	
(18)	<input type="radio"/>	
(36)	<input type="radio"/>	
(62)	<input checked="" type="radio"/>	<input type="radio"/> Consult Rossi S.p.A.
(63)	<input type="radio"/>	<input checked="" type="radio"/> Possible

(49) IP 65 protection

Advised both for motors running in dusty environments and to avoid that wear dust of friction surface is dispersed in the environment (e.g. food industry).

Seal between the coupling surfaces of housing and endshields (to be re-adjusted when disassembling the motor).

IP 65 brake protected with: rear V-ring, O-rings on fastening screws of brake and on the pullers of the release hand lever.

In damp and/or aggressive environment, in case of condensate and/or mildew dangers or of long brake standstill, it is recommended to require the «Design for damp and corrosive environment» (47),

if necessary also with «Stainless steel bolts and screws» (described always in (47)).

Non-standard design code for the **designation**: ,IP 65

Non-standard design	63 ... 160S	
(17)	<input type="radio"/>	
(18)	<input type="radio"/>	
(36)	<input checked="" type="radio"/>	
(62)	<input checked="" type="radio"/>	<input type="radio"/> Consult Rossi S.p.A.
(63)	<input type="radio"/>	<input checked="" type="radio"/> Possible

(53) Brake with microswitch

Brake equipped with a mechanical microswitch in order to indicate **brake wear or brake jam/release**:

- supply: 250 V a.c. max. 6 A;
- protection degree IP 67;
- terminals are wired to a fixed or loose terminal block inside the terminal box (for wiring schemes see fig. below).

Not possible with BZ12 brake
(motor 63, 71A2 and 71A8);

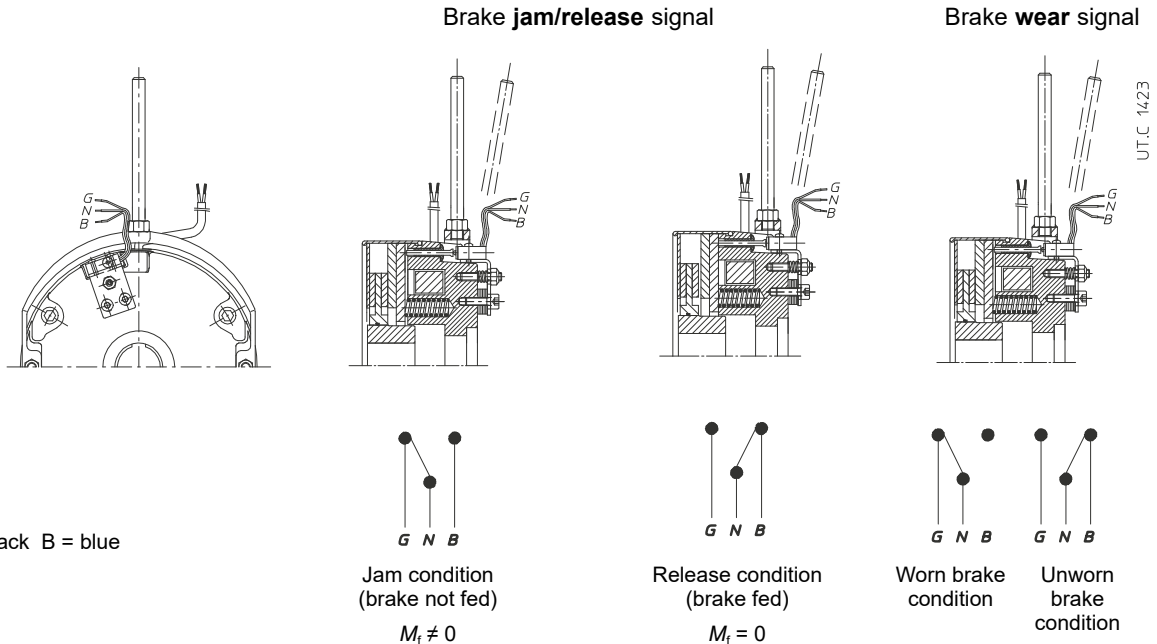

Non-standard design code for the **designation**:

,SB (brake **jam/release** signal)

,SU (brake **wear** signal)

(54) Brake with ready air-gap reset

Brake equipped with removable thin spacers placed under the brake fastening studs; with this solution the brake air-gap is **ready to be reset** without adjusting with a thickness gauge and without disassembling the brake itself (**patent pending**).

When the brake disc wear reaches its maximum value, **the air-gap reset** is carried out simply **removing a series of thin spacers** after having partially loosen the brake fixing bolts (no dismounting is required).

The brake is supplied with two series of thin spacers of different color (yellow and red) to allow two adjustment operations (normally enough if compared with the motor and the brake lifetime).

This design can be also associated with design «Brake with microswitch» (53).

Non-standard design code for **designation**: **,RF**

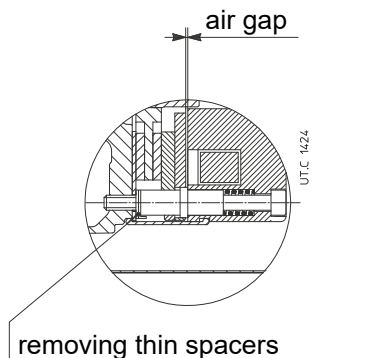

(61) Manual rotation

Pre-arranged for **manual rotation** by straight setscrew (see table) that can be fitted on non-drive end motor shaft (excluded non-standard designs «Axial independent cooling fan» and «Axial independent cooling fan and encoder» ch. 4.9 (17), (18) and (63) To be always combined with special execution 25 (level for manual realase wuith automatic return).

Non-standard design code for the **designation: ,MM**

Motor size	Wrench 
63, 71	5
80, 90	6
100, 112	8
132 ... 160S	10

(62) Motor prearranged for encoder

Motor prearranged for encoder with following features:

- anti-rotation center distance Ø 63 mm
- flexible anti-rotation bracket with 1 or 2 holes/slots at 180° suitable for screw passage M3
- max encoder height 48 mm
- motor shaft Ø 10 h6 mm.

Motor dimensions as per encoder design (36).

Non-standard design code for the **designation: ,PE**

(63) Axial independent cooling fan and prearranged for encoder

Independently cooled motor prearranged for encoder with following features:

- anti-rotation center distance Ø 63 mm;
- flexible anti-rotation bracket with 1 or 2 holes/slots at 180° suitable for screw passage M3;
- max encoder height 48 mm;
- motor shaft Ø 10 h6 mm and length 35 mm.

For specifications and independent cooling fan designation code see design (17).

Motor overall dimensions as «Axial independent cooling fan» (17).

Non-standard design code for the **designation: ,V... PE**

Miscellaneous

- Asynchronous three-phase two-speed motors.
- Asynchronous single-phase motors with running capacitor always switched on, running + starting and electronic disjuncter, balanced winding.
- Special paints or completely unpainted motor.
- Motor balancing according to reduced vibration degree (B) to CEI EN 60034-14.
- Motors with integral feet and flange (IM B35, IM B34 and relevant vertical mounting positions).
- Power connector.
- Sensorized drive end bearing (32, 48 or 64 pulses per revolution) for the measurement of angle and/or rotation speed (sizes 63 ... 100); for specifications and wiring schemes consult us.
- Pt 100 temperature probe.
- Encoder for high temperatures.
- Designs with supply cable.
- Design for oil seal (e.g. coupled with mechanical variator).
- Motor certified to ATEX II categories 3G and 3D.
- Design for high temperature.
- Brakes with different adjustment and/or of smaller size.
- Special release lever rod to keep brake release condition.
- Design with double brake (theaters).
- Design with adjustable braking torque.

Name plate

				IEC 60034-1			
MOT.(1)~ (9)	(2) (3) (4) (5)	IP (6)	AMB. (7)	IC (8)			
(14)	(10)	kg (11)	I.CL. (12)	S (13)			
(15)	Frano Brake (30)	Nm (31)	V~/Hz (32)	A (33)	#/#/# (34)	V= (35)	
DE/NDE (16)							
(17)							
(19) v (19)	% (21)	Hz (22)	% (23)	A (24)	kW (25)	min ⁻¹ (26)	cos φ (27)
(20)							
(28)							
(29)							

UTC 2291

				IEC 60034-1			
MOT.(1)~N. (9)	(10)	IP (6)	AMB. (7)	IC (8)			
(2) (3) (4) (5)		kg (11)	I.CL.(12)S (13)				
Frano Brake (30)	Nm (31)	V~/Hz (32)	A (33)	#/#/# (34)	V= (35)		
(14)							
(15)							
(10)							
NEMA MG1-12 SF (36) DESIGN (29) CODE (29)							
(19) V (19)	Hz (22)	A (24)	HP (25)	RPM (26)	PF (27)	NOM. EFF (28)	
(20)							
ENERGY Verified for energy efficiency in accordance with US DOE 10CFR431, dated September 22, 2015							
Verified for energy efficiency in accordance with CSA C390-10, dated March 2010, reaffirmed 2015							
CC131B E304505							

UTC 2169A

NEMA YY230 Y460 V, 60Hz

- (1) Number of phases
- (2) Motor type
- (3) Size
- (4) Number of poles
- (5) Designation of mounting position
- (6) Protection IP ...
- (7) Maximum ambient temperature
- (8) Code IC
- (9) Production number
- (10) Two months and year of manufacturing end serial number
- (11) Motor mass
- (12) Insulation class I.CL....
- (13) Duty cycle S...
- (14) Motor code
- (15) Customer code¹⁾
- (16) Bearings
- (17) Note 1
- (18) Note 2
- (19) Connection of the phases
- (20) Nominal voltage
- (21) Voltage tolerance
- (22) Nominal frequency
- (23) Frequency tolerance
- (24) Nominal current
- (25) Nominal power
- (26) Nominal speed
- (27) Nominal power factor
- (28) Nominal efficiency IEC 60034-2-1
- (29) Design - code
- (30) Brake size
- (31) Brake braking torque
- (32) Rectifier supply
- (33) Current absorbed by brake
- (34) Rectifier designation
- (35) D.c. nominal voltage of brake supply
- (36) Service factor

1) On request.

				IEC 60034-1			
MOT. 3 ~ HB3Z 90L 4 B5	IP 55	AMB. 40°C	IC 411				
2383840 03/21 7631421	kg 25	I.CL. F	S 1				
R000246492	Frano Brake BZ05	Nm 27	V~/Hz 110-440/50-60	A 0.26	#/#/# RM2	V= 103	
DE/NDE h g							
(17)							
Δ V Y	%	Hz	%	A	kW	min ⁻¹	cos φ
220/380		50		5.9/3.4	1.5	1415	0.81
230/400		50		5.7/3.3	1.5	1430	0.78
240/415		50		5.7/3.3	1.5	1430	0.76
265/460		60		5.0/2.9	1.5 SF1.15	1740	0.74
277/480		60		5.0/2.9	1.5 SF1.2	1745	0.72
50/60Hz: IE3 85.3/86.5(100%) 86.1/87.3(75%) 85/85.5(50%)							
60Hz NEMA NOM. EFF. 86.5% 2 hp DES.C CODE. L/L							

UTC 2371

				IEC 60034-1			
MOT.3~N.1801516 06/16	IP 55	AMB. 40°C	IC 411				
HB3Z 112M 4 B5	kg 33	I.CL.F S 1					
Frano Brake BZ15	Nm 40	V~/Hz 200÷440/50÷60	A 0,26	#/#/# RM2	V= 103		
R000135969 6473681							
NEMA MG1-12 SF 1,15 CONT. DESIGN A CODE M							
YY V Y	Hz	A	HP	RPM	PF	NOM. EFF	
230/460	60	10,6/5,3	4	1750	79%	89,5%	
ENERGY Verified for energy efficiency in accordance with US DOE 10CFR431, dated September 22, 2015							
Verified for energy efficiency in accordance with CSA C390-10, dated March 2010, reaffirmed 2015							
CC131B E304505							

UTC 2170A

4.12

Standard voltage/frequency on name plate

Motors required with supply voltage $\Delta 230$ Y400V 50Hz are supplied as standard with the following voltage/frequency values stated on motor nameplate, see following table:

Motor Type	Voltage/Frequency on nameplate	Voltage/Frequency on nameplate with design ,UL (42)
HBZ	230.400 50 265.460.60	230.400 50 265.460.60
HB2Z	220.380 50 230.400 50 240.415 50 265.460 60 277.480 60	230.400 50 265.460 60 277.480 60
HB3Z 2, 4 Poles	220.380 50 230.400 50 240.415 50 265.460 60 277.480 60	230.400 50 265.460 60 277.480 60
HB3Z 6 Poles	220.380 50 230.400 50 240.415 50	230.400 50

Other voltage types are available on request as already explained in the design (1) "Non-standard motor supply", in the specific case only the required supply will be stated on nameplate.

This page is intentionally left blank.

Brake motor for specific applications HBF

Section Contents

5.1	General specifications	112
5.2	Designation	113
5.3	Specifications	113
5.4	Radial and axial loads on shaft end	117
5.5	Motor brake specifications	118
5.6	Technical data 400V 50 Hz	121
5.7	Technical data 230.460V 60 Hz	126
5.8	Technical data 380V 60 Hz	130
5.8	Motor dimensions	132
5.9	Non-standard designs and accessories	135
5.10	Name plate	144
5.11	Standard voltage/frequency on name plate	145

5.1

General specifications

General specifications

Brake motor with alternate current brake for specific applications

63 ... 160S

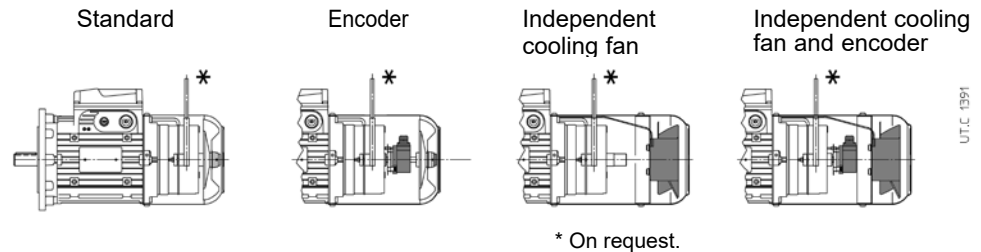

- Brake motors with a.c. brake – Sizes 63 ... 160S available also with **powers** (marked by*) **higher than the ones foreseen by the standards.**
- Class F insulation; temperature rise class B for motors at standard power, F for remaining motors
- **Mounting positions IMB5 and derivatives, IM B14 and derivatives (on request) and IM B3** (always pre-arranged) and corresponding vertical mounting position; **mating tolerances under «accuracy» rating**
- **IP 55** protection
- **Particularly strong construction** (both electrical and mechanical) to withstand alternating torsional and thermic stresses of starting and braking; duly proportioned bearings
- **«Supported» tightening attachments** of endshields and flanges fitted on housing with **«tight»** coupling
- Electromagnetic sizing especially studied to allow high acceleration capacity (high frequency of starting) and uniform starting (slightly «sagged» characteristic curves)
- **Suitable for operation with inverter**
- **Asbestos-free** friction surfaces
- **Wide metallic** terminal box, possibility of **direct** or **separate** brake supply
- **Designs available for every application need.**
- High braking capacity
- Double braking surface, high braking torque (usually $M_t \gg 2M_N$) and step adjustable.
- **Maximum quickness** and **precision** in releasing and braking (typical of a.c. brake) and maximum frequency of braking
- Maximum frequency of starting for the motor (rapidity in brake releasing allows a completely free start also at high frequency of starting)
- Particularly suitable for applications requiring strong and very rapid brakings together with a high number of starts
- **HBF** includes a **comprehensive range of accessories and non-standard designs** in order to satisfy the wide gearmotor application needs (e.g.: IP 56, IP 65, encoder, independent cooling fan, independent cooling fan and encoder, second shaft end, etc.).

For standard voltages as per name plate see ch. 5.11

Designation

MOTOR	HB	asynchronous three phase
EFFICIENCY CLASS	–	$P_N \geq 0,75$ kW Duty S3 70%
BRAKE TYPE	F	according to motor supply: - IE2 (ErP) - IE3 (ErP) - Premium Efficiency (EISA) freno a c.a.
SIZE	63 ... 160S	
NUMBER OF POLES	2, 4, 6	
SUPPLY¹⁾	230.400-50 230.460-60 ²⁾	Δ 230 Y400 V 50 Hz YY230 Y460 V 60 Hz
MOUNTING POSITION	B5, B14, B3, B5R, B5A, ... B14R	IM B5, IM B14 (63 ... 132), IM B3, non-standard IM B5 non-standard IM B14
Non-standard design	,... ,... ,...	code, see ch. 5.9

HB	F	80	B	2	230.400-50	B5R ,E1
HB 2	F	71	B	4	230.400-50	B5R
HB 3	F	90	L	4	230.400-50	B5

1) May frequency and voltage differ from those stated above, see ch. 5.9 (1).

2) Motor supply for USA and Canada (EISA): includes also terminal block with 9 terminals (see ch. 5.9 (10)) and UL compliance (see ch. 5.9 (42)); not possible for 8 pole motors.

5.3

Specifications

Asynchronous three-phase electric **brake motor** with **a.c. brake** (braking in case of failure of supply) with double braking surface, sizes **63 ... 160S**.

Standardised motor with cage rotor, totally enclosed, externally ventilated (cooling system IC 411), single-speed according to following tables:

Number of poles	Winding	Motor size	Standard supply		Class	
			50 Hz	60 Hz	insulation	temperature rise
2, 4, 6	three-phase Δ Y	63 ... 160S	50 Hz	see ch. 5.11	F	B ¹⁾
4, 6	three-phase YY Y		60 Hz	YY 230 Y460 V		

1) Excluding some motors with higher power than the ones standardised (identified by □ at ch. 5.6 and 5.7) whose temperature rise class is F.

IP 55 protection: drive end motor with seal ring (without spring for IM B3) and non-drive end with water-proof and dust-proof gaiter and V-ring.

Rated power delivered in continuous duty (S1) and at standard voltage and frequency; ambient temperature -15 ± 40 °C, altitude 1 000 m.

Mounting positions IM B5, IM B3 IM B14; motors can also operate in the relevant mounting positions with vertical shaft, which are respectively (see following table): IM V1 and IM V3, IM V18 and IM V19, IM V5 and IM V6; the name plate shows the designation of mounting position with horizontal shaft.

On request, other special mounting positions: consult Rossi S.p.A.

Mounting positions with flange

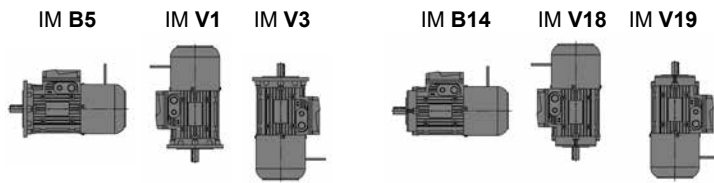

Mounting positions with feet

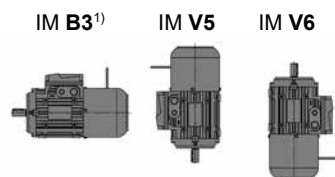

1) Motor can also operate in the mounting positions IM B6, IM B7 and IM B8; the name plate shows the IM B3 mounting position.

Main mating dimensions of the mounting positions with flange

Mounting position	Shaft end - Ø D x E Flange - Ø P								
	Motor size								
	IM	63	71	80	90	100	112	132	160S
B3	11 x 23	14 x 30	19 x 40	24 x 50	28 x 60	28 x 60	38 x 80	42 x 110	
B5	11 x 23 140	14 x 30 160	19 x 40 200	24 x 50 200	28 x 60 250	28 x 60 250	38 x 80 300	42 x 110 350	
B5R	9 x 20 120	11 x 23 140	14 x 30 160	19 x 40 200	24 x 50 200	24 x 50 200	28 x 60 250	-	
B5S	-	-	-	14 x 30 160 ¹⁾	19 x 40 200	19 x 40 200 ¹⁾	24 x 50 200 ¹⁾	-	
B5A	11 x 23 120	14 x 30 140	19 x 40 160	-	28 x 60 200	28 x 60 200	38 x 80 250	-	
B5B	-	11 x 23 120	14 x 30 140	19 x 40 160	-	-	28 x 60 200	-	
B5C	-	-	-	-	19 x 40 160	-	-	-	
B14	11 x 23 90	14 x 30 105	19 x 40 120	24 x 50 140	28 x 60 160	28 x 60 160	38 x 80 200	-	
B14R	-	11 X 23 90	14 x 30 105	-	-	-	-	-	

1) For $P_{N \max}$ available see table below.

Motor size	Poles					
	2		4		6	
	$P_{N \max}$ kW [hp]					
90	1,85	[2.4]	1,1	[1.5]	0,75	[1]
112	4	[5.4]	3	[4]	1,85	[2.4]
132	9,2	[12.4]	7,5	[10]	4	[5.4]

Housing in pressure diecast light alloy; mounting position IM B3 with inserted feet which, for sizes 90 ... 160S, can be mounted on **three sides**.

Drive (or flange) end and **non-drive end endshield** in cast iron or light alloy (see table).

«Supported» **tightening attachments** of endshields and flanges fitted on housing with «tight» coupling.

Ball bearings (see table below) lubricated «for life» assuming pollution-free surroundings; preload spring.

Driving shaft: in through-hardened steel 39 NiCrMo3 or C45 depending on size, **axially fastened** on rear endshield. Cylindrical shaft ends with A-shape (rounded) key and tapped butt-end hole (see table where: d = tapped butt-end hole; bxhxl = key dimensions).

Rear threaded hole for dismantling in applications with gear reducer, as standard.

Motor size	Endshield material and bearings			
	drive end		non-drive end	
63	LL	6202 2Z	6202 2RS	LL
71	LL	6203 2Z	6203 2RS	LL
80	LL	6204 2Z	6204 2RS	LL
90	LL	6205 2Z	6205 2RS	LL
100	LL	6206 2Z	6206 2RS	LL
112	LL	6306 2Z	6306 2RS	LL
132	LL ¹⁾	6308 2Z	6308 2Z	LL
160S	G	6309 2Z	6308 2Z	LL

LL = light alloy G = cast iron

1) In cast iron for IM B14 and IM B5 derivatives.

	Shaft end - Ø × E							
	Ø 9×20	Ø 11×23	Ø 14×30	Ø 19×40	Ø 24×50	Ø 28×60	Ø 38×80	Ø 42×110
d	M3	M4	M5	M6	M8	M10	M12	M16
b×h×l	3×3×12	4×4×18	5×5×25	6×6×32	8×7×40	8×7×50	10×8×70	12×8×100

Steel fan cover.

Thermoplastic **cooling fan** with radial blades.

Terminal box in light alloy integral with housing with cable knockout openings on both sides, two openings per side one for power cable and one for auxiliary equipment.

Position opposite to feet for mounting position IM B3; on request available on right or left side (see ch. 5.9 (14)). Pressure diecast light alloy terminal box cover.

Terminal block with 6 terminals (9 terminals for YY230 YT 460 60 Hz voltage supply; terminal dimensions in the table below).

Motor size	Terminal block		Seal rings
	terminals ¹⁾	cable entry ²⁾	
63	M4	4 × M16	15 × 30 × 4,5
71	M4	2 × M16 + 2 × M20	17 × 32 × 5
80	M4	2 × M16 + 2 × M20	20 × 35 × 7
90	M5	2 × M16 + 2 × M25	25 × 46 × 7
100, 112	M5	2 × M16 + 2 × M25	30 × 50 × 7
132	M6	2 × M16 + 2 × M32	40 × 60 × 10
160S	M6	2 × M16 + 2 × M32	45 × 65 × 10 ³⁾

1) 6 terminals for cable terminal connection.

2) Terminal box provided with knockout openings (for sizes 63 ... 160S cable gland not supplied).

3) Non-drive end: 40x60x10.

Earth terminal located inside terminal box; prearranged for the installation of two further external earth terminals on housing.

Brake supply: with auxiliary terminal block; possible brake supply **directly from motor terminal block** or **separately** (condition of supply, to be used for: motors supplied by inverter, separate drive needs of motor and brake, etc.).

Pressure diecast cage **rotor** in aluminium.

Stator winding with class H copper conductor insulation, insulated with double coat, type of impregnation with resin of class H; other materials are of classes F and H for a **class F insulation system**.

Rotor dynamic balancing: vibration velocity under standard rating A. Motors are balanced with half key inserted into shaft extension.

Paint: double-compound, water-soluble, polyacrylic resin based, corrosivity class C3 (to ISO 12844-2), colour blue RAL 5010 DIN 1843, unaffected by normal industrial environments and suitable for further finishings with double-compound synthetic paints.

For **non-standard designs** and accessories see ch. 5.9.

Compliance with European Directives

Motors of present catalog comply with following standards EN 60034-1, EN 60034-2, EN 60034-2-1, EN 60034-5, EN 60034-6, EN 60034-7, EN 60034-8, EN 60034-9, EN60034-12, EN 60034-14, IEC 60038, IEC 60072-1, and with **Low Voltage Directive 2014/35/EU**

For this reason the electric motors are CE marked.

Additional information:

The motor design, considering the motors as components, complies with

- Machinery Directive 2006/42/EC when the installation is correctly executed by machinery manufacturer (e.g.: in compliance with our installation instructions and EN 60204 «Electric Equipments of Industrial Machines»);
- Directive 2011/65/EC RoHS relevant to the limit of use of dangerous substances in the electric and electronic equipments.

Declaration of Incorporation (Directive 2006/42/EC Art 5.2 – II B):

The above mentioned motors must be commissioned as soon as the machines in which they have been incorporated have been declared to be in compliance with the Machinery Directive.

According to EN60034-1, as motors are components and not machines, supplied directly to the final user, the Electromagnetic

Radial and axial loads on shaft end

Compatibility Directive 2014/30/EU is not directly applicable.

Radial loads generated on the shaft end by a drive connecting motor and driven machine must be less than or equal to those given in the relevant table.

The radial load F_r , given by the following formula refers to most common drives:

$$F_r = \frac{k \cdot 19100 \cdot P}{n \cdot d} \text{ [N]}$$

dove:

P [kW] is motor power required

n [min^{-1}] is the speed

d [m] is the pitch diameter

k is a coefficient assuming different values according to the drive type:



$k = 1$ for chain drive

$k = 1,1$ for gear pair drive

$k = 1,5$ for timing belt drive

$k = 2,5$ for V-belt drive

The table shows maximum permissible values of radial and axial loads on driving shaft end (F_r overhung load on centre line of shaft end), calculated for a bearing life $L_n = 18\,000$ h. For a longer bearing life, the values stated in the table must be multiplied by: 0,9 (25000 h),

Motor size	$F_r^{1)}$ [N]				$F_a^{2)}$ [N]							
												
	n_N [min^{-1}]				n_N [min^{-1}]				n_N [min^{-1}]			
	3000	1500	1000	750	3000	1500	1000	750	3000	1500	1000	750
63	420	530	600	670	200	290	350	400	210	290	350	400
71	510	640	740	810	210	310	380	440	210	310	380	440
80	650	830	950	1050	230	350	420	500	370	500	600	680
90S	710	900	1040	1140	250	390	490	570	250	390	490	570
90L	730	930	1050	1180	240	380	480	560	240	380	480	560
100	1000 ³⁾	1300	1500	1650	300	490	620	730	370	570	710	820
112	1500 ³⁾	1900	2150	2400	660	950	1150	1310	660	950	1150	1310
132	2000 ³⁾	2500	3000	3250	1220	1650	1960	2200	1220	1650	1960	2200
160S	2500	3150	3650	4050	1720	2280	2670	2990	1220	1650	1960	2200

1) An axial load of up to 0,2 times the value in the table is permissible, simultaneously with the radial load.

2) Comprehensive of a possible unfavourable effect of weight-force of rotor and bearing preload spring.

3) For radial load value near to table limit require bearings C3.

For running at 60 Hz, table values must be reduced by 6%.

5.5

Motor brake specifications

63 ... 160S

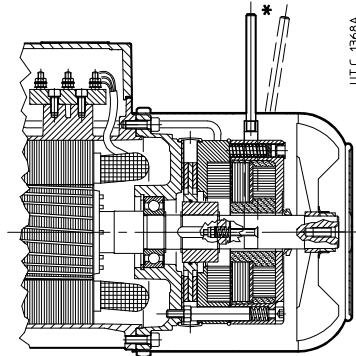

* A richiesta.

Electromagnetic spring loaded brake (braking occurs automatically when it is not supplied), running at **alternate current**, with double braking surface and **high braking torque** (usually $M_f \gg 2 M_N$).

Conceived for **maximum quickness and precision** in releasing and braking (typical of a.c. brake) and **maximum frequency of braking, high braking capacity, high number of brakings** between two airgap adjustments (more than the double compared to the other brake motors), maximum frequency of starting for the motor (rapidity in brake releasing allows a completely free start also at high frequencies of starting).

This brake motor is particularly suitable for heavy duties requiring **powerful and very quick brakings** and a high number of operations (e.g.: hoists with high frequency of starting, normally for sizes > 132, and/or with jog operations).

Vice versa, its very **high dynamic characteristics** (maximum braking capacity, rapidity and frequency of starting) **are not advisable for the use in gearmotor coupling**, especially when these features are not strictly necessary for the application (avoiding useless overloads on the whole transmission).

Comprehensive range of non-standard designs: encoder, independent cooling fan, independent cooling fan and encoder, second shaft end, etc..

When electromagnet is not supplied, the brake anchor pushed by springs, presses the brake disk on rear endshield generating the braking torque on the same brake disk and consequently on motor shaft it is keyed onto; by supplying the brake the electromagnet draws the brake anchor and releases brake disk and driving shaft.

Main specifications:

- three-phase alternate supply voltage (in the connection the a.c. electromagnet is similar to an asynchronous three-phase motor) matching the motor supply (see 5.9 (1));
- **brake terminal block** for brake supply **directly from terminal block** of motor or indifferently from **separate** line;
- **insulation class F, temperature rise class B**;
- Windings and electromagnet core **laying into insulating resin** in order to grant a good life and withstanding in terms of shocks, vibrations and thermal shocks deriving from heavy duties of brake and in order to have a noiseless duty;
- **brake anchor made of cast iron**;
- brake disk sliding on the steel splined moving hub, always with steel core for the maximum reliability of keying and double friction surface with average friction coefficient for low wear;
- **water-proof and dust-proof gaiter** and **V-ring** both to prevent polluting infiltrations from surroundings towards brake, and to avoid that wear dust of friction surface will be dispersed in the surroundings;
- on request, prearranged for **manual rotation** by straight setscrew (wrench 5 for sizes 63 and 71, 6 for 80 and 90, 8 for 100 and 112, 8 for 132) that can be fitted on non-drive end motor shaft;
- on request, only, **lever for manual release with automatic return** and removable lever rod; position of release lever corresponding to terminal box as in the schemes at point 5.9; on request, other possible positions;
- for other operational features see the following table.

For general motor specifications see ch. 5.3.

For non-standard designs see ch. 5.9.

Table of main functional specifications of brake

Effective values may slightly differ according to ambient temperature and humidity, brake temperature and state of wear of friction surface

Brake size	Motor size	M_f [N m] ²¹⁾			Absorption		Delay of ²²⁾		Air-gap		W_1	C_{max}	W_{max} ²⁶⁾ [J]		
							release	braking							
		Spacer number (primed)	A D230 / Y400 ± 5% 50 Hz	W	t_1 ms	t_2 ²³⁾ ms	mm nom	mm max	MJ/mm 24)	mm 25)	brakings/h				
BF 12	63, 71	1,75 ⁰	3,5 ²	–	0,15 / 0,09	19	4	20	0,25	0,40	70	5	4500	1120	160
BF 53, 13	71, 80	2,5 ⁰	5 ¹	7,5 ³	0,20 / 0,12	25	4	40	0,25	0,40	90	5	5600	1400	200
BF 04, 14	80, 90	5 ⁰	11 ¹	16 ²	0,28 / 0,16	37	6	60	0,30	0,45	125	5	7500	1900	265
BF 05, 15	90, 100, 112	13 ⁰	27 ²	40 ⁴	0,63 / 0,36	48	8	90	0,30	0,45	160	5	10000	2500	355
BF 06S	112	–	40 ²	60 ³	1,18 / 0,68	58	16	120	0,35	0,55	220	5	14000	3550	500
BF 06	132	50 ⁰	75 ²	–	1,38 / 0,79	63	16	140	0,35	0,55	200	4,5	14000	3550	500
BF 07	132, 160S	50 ⁰	100 ³	150 ⁵	1,51 / 0,86	78	16	180	0,40	0,60	315	4,5	20000	5000	710

21) Braking torque values (±12%) corresponding to number of installed spacers under the spring (primed).

22) Values valid for $M_f = M_{fmax}$, mean air-gap, nominal value of supply voltage.

23) Braking delay obtained by separate brake supply; with direct supply from motor terminal block, the values of t_2 increase of approx. 2,5 times the ones to table.

24) Friction work for brake disc wear of 1 mm (minimum value for heavy use; real value is usually greater).

25) Maximum brake disk wear.

26) Maximum friction work for each braking.

5.6

Technical data 400V 50Hz

2 poles - 3000 min⁻¹

IP 55

IC 411

Insulation class F

Temperature rise class B

IE2 P_N 0,12 ... 0,55 kW

P_N ≥ 0,75 kW S3 70%

400V - 50Hz

ErP

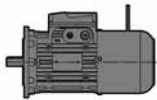

P _N kW	Motor	n _N min ⁻¹	M _N N m	I _N A 400 V	cos φ	η			M _S / M _N	M _{max} / M _N	I _S / I _N	J ₀ kg m ²	Brake	M _f N m	z ₀ starts/h	kg
						IEC 60034-2-1										
						100%	75%	50%								
0,18	HB2F 63 A 2	2800	0,61	0,56	0,71	68,7	66,6	60,7	3,1	3,3	4,1	0,0002	BF 12 1,75	4750	5,3	
0,25	HB2F 63 B 2	2780	0,86	0,75	0,71	70,5	68,9	63,1	3,1	3,2	4,1	0,0003	BF 12 1,75	4750	5,9	
0,37 *	HB2F 63 C 2	2790	1,26	1,02	0,72	73,3	72,4	67,3	3,5	3,3	4,5	0,0003	BF 12 3,5	4000	6,5	
0,37	HB2F 71 A 2	2800	1,26	0,95	0,77	75	74,7	70,8	3,1	3,3	5,2	0,0004	BF 12 3,5	4000	7,5	
0,55	HB2F 71 B 2	2820	1,86	1,33	0,78	77,3	76,9	72,9	3,6	3,7	5,8	0,0005	BF 53 5	4000	9,1	
0,75 *	HB2F 71 C 2	2830	2,53	1,85	0,79	73,8	72,9	68,7	3,5	3,7	5,7	0,0006	BF 53 5	3000	9,9	
0,75	HB2F 80 A 2	2850	2,51	1,85	0,75	78,3	77,7	74,3	3,6	3,8	6,1	0,0009	BF 13 5	3000	10	
1,1	HB2F 80 B 2	2840	3,7	2,6	0,77	79,5	80,1	78,3	3,6	3,8	6,1	0,0011	BF 04 11	3000	12,5	
1,5 *	HB2F 80 C 2	2890	4,96	3,5	0,76	81,2	81,4	78,9	4	4,4	7,4	0,0014	BF 04 11	2500	14,5	
1,85 *	HB2F 80 D 2	2820	6,3	4,2	0,8	79,8	81,2	80,1	3,7	3,8	6,2	0,0015	BF 04 16	2500	15	
1,5	HB2F 90 S 2	2840	5	3,4	0,81	78,5	78,9	77	3	3,2	5,7	0,0016	BF 14 11	2500	17	
1,85 *	HB2F 90 SB 2	2860	6,2	4,2	0,8	79,3	79,6	77,1	3,2	4	6,1	0,0018	BF 14 16	2500	18,5	
2,2	HB2F 90 LA 2	2880	7,3	4,9	0,8	81	80,7	78	3,8	4,5	7	0,0024	BF 05 27	2500	23	
3 *	HB2F 90 LB 2	2870	10	6,6	0,8	82	82,2	80,1	3,7	4,1	6,8	0,0028	BF 05 27	1800	25	
3	HB2F 100 LA 2	2860	10	6,8	0,78	81,5	82	80,1	3,6	3,8	6	0,0035	BF 15 27	1800	27	
4 *	HB2F 100 LB 2	2860	13,4	8,8	0,79	83,1	82,5	80	3,8	4,4	7	0,0046	BF 15 27	1500	31	
4	HB2F 112 M 2	2880	13,3	8,8	0,79	83,3	83,6	82	3	3,8	6,2	0,0054	BF 15 27	1500	34	
5,5 *	HB2F 112 MB 2	2890	18,2	11,6	0,81	84,7	84,9	83,2	3,3	3,7	7,2	0,0072	BF 15 40	1400	38	
7,5 *	HB2F 112 MC 2	2870	25	16,5	0,79	83	84,4	83,7	3	3,7	6,4	0,0085	BF 06S 60	1060	43	
5,5	HB2F 132 S 2	2900	18,1	11,3	0,83	84,7	84,3	82,1	2,6	3,4	6,3	0,0112	BF 06 50	1250	55	
7,5	HB2F 132 SB 2	2910	24,6	14,3	0,87	86,9	87,2	85,5	2,9	3,7	7,2	0,0146	BF 06 50	1120	58	
9,2 *	HB2F 132 SC 2	2910	30,2	18,7	0,82	87	87,3	85,67	3	3,8	7,7	0,0168	BF 06 75	1060	60	
11 *	HB2F 132 MA 2	2920	36	20,5	0,88	87,6	87,5	85,9	3,2	3,9	8,3	0,0214	BF 07 100	850	69	
15 *	HB2F 132 MB 2	2920	49,1	30	0,85	88,7	86,2	84	3,7	4,1	8,3	0,0271	BF 07 100	710	80	
11	HB2F 160 SA 2	2920	36	20,5	0,88	87,6	87,5	85,9	3,2	3,9	8,3	0,0214	BF 07 100	850	78	
15	HB2F 160 SB 2	2920	49,1	30	0,83	88,7	86,2	84	3,9	4,3	8,3	0,0271	BF 07 100	710	89	

Efficiency value not complying with IE3 class range (IEC 60034-30); nominal power and name plate referred to S3 70% intermittent duty.

*) Power or motor power-to-size correspondence not according to standard.

□ Temperature rise class F.

Technical data 400V 50Hz

2 poles - 3000 min⁻¹
 IP 55
 IC 411
 Insulation class F
 Temperature rise class B

IE3
400V - 50Hz
ErP

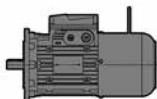

UT.C 1373

P _N	Motor	n _N	M _N	I _N	cos φ	η			M _S /M _N	M _{max} /M _N	I _S /I _N	J ₀	Brake	M _f	z ₀	kg
						IE3 IEC 60034-2-1										
kW		min ⁻¹	N m	A 400 V		100%	75%	50%			kg m ²		N m	starts/h		
0,75	HB3F 80 A 2	2870	2,5	1,7	0,78	80,7	79,9	76,7	3,6	3,8	7,3	0,001	BF 13	5	2500	10,4
1,1	HB3F 80 B 2	2875	3,7	2,3	0,84	82,7	83,2	81	3,9	3,9	7,7	0,0015	BF 04	11	2500	15,4
1,5	HB3F 90 S 2	2890	4,97	2,9	0,88	84,2	84,5	83,3	3,3	3,6	7,9	0,0021	BF 14	11	1800	20
2,2	HB3F 90 LA 2	2890	7,3	4,4	0,85	85,9	86,2	85,1	3,9	4,4	8,4	0,0027	BF 05	27	1600	25
3	HB3F100 LA 2	2930	9,8	6,2	0,80	87,1	87,2	85,2	4,2	5,1	10,1	0,0048	BF 15	27	1500	31
4	HB3F112 M 2	2940	13	7,6	0,87	88,1	88,2	86,7	2,8	4,2	9,8	0,0078	BF 15	27	1400	40
5,5	HB3F132 S 2	2960	17,8	10,4	0,85	89,2	88,6	85,6	5,2	6,1	12,7	0,0184	BF 06	50	710	65
7,5	HB3F132 SB 2	2960	24,3	14	0,85	90,1	89,9	87,3	5,7	6,5	13,6	0,0225	BF 06	50	710	73,5
9,2 *	HB3F132 SC 2	2960	29,7	17,3	0,84	90,7	89,9	87,4	5,7	6,3	13,4	0,0253	BF 06	75	710	79
11 *	HB3F132 MA 2	2950	35,7	20	0,87	91,2	90,1	88,4	5,2	4,9	11,6	0,0265	BF 07	100	710	81,5
11	HB3F160 SA 2	2950	35,7	20	0,87	91,2	90,1	88,4	5,2	4,9	11,6	0,0265	BF 07	100	710	90,5

*) Power or motor power-to-size correspondence not according to standard.

5.6

Technical data 400V 50Hz

4 poles - 1500 min⁻¹

IP 55

IC 411

Insulation class F

Temperature rise class B

IE2 P_N 0,12 ... 0,55 kW

P_N ≥ 0,75 kW S3 70%

400V - 50Hz

ErP

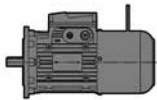

P _N kW	Motor	n _N min ⁻¹	M _N N m	I _N A 400 V	cos φ	η IEC 60034-2-1			M _S /M _N	M _{max} /M _N	I _S /I _N	J ₀ kg m ²	Brake	M _f N m	z ₀ starts/h	kg
						100%	75%	50%								
0,12	HB2F 63 A 4	1370	0,84	0,46	0,63	61,4	58,9	51,9	2,5	2,6	3,1	0,0003	BF 12	1,75	12500	5,5
0,18	HB2F 63 B 4	1350	1,28	0,64	0,66	65	64,1	58,4	2,6	2,5	3,3	0,0004	BF 12	3,5	12500	6,1
0,25 *	HB2F 63 C 4	1360	1,76	0,83	0,65	68,5	67,8	62,8	2,8	2,7	3,5	0,0004	BF 12	3,5	10000	6,9
0,25	HB2F 71 A 4	1400	1,71	0,8	0,71	68,5	66,6	60,7	2,3	2,6	3,8	0,0008	BF 53	5	10000	8,1
0,37	HB2F 71 B 4	1400	2,52	1,1	0,70	73,2	72,2	67,3	2,7	3,2	4,6	0,001	BF 53	5	10000	9
0,55 *	HB2F 71 C 4	1400	3,75	1,5	0,70	77,1	75,7	72	3,3	3,5	5,1	0,0014	BF 53	7,5	8000	10,5
0,75*	HB2F 71 D 4	1370	5,2	2,15	0,7	72,1	73,3	69,1	2,8	2,9	4	0,0014	BF 53	7,5	7100	10,5
0,55	HB2F 80 A 4	1420	3,69	1,34	0,78	77,1	76	72	2,9	3,1	5,8	0,0025	BF 04	11	8000	13
0,75	HB2F 80 B 4	1410	5,1	1,9	0,77	74,7	74,2	70,5	2,8	3	5,2	0,0025	BF 04	11	7100	13
1,1 *	HB2F 80 C 4	1400	7,5	2,8	0,79	75	75,6	72	2,9	3	5,2	0,0033	BF 04	16	5000	15
1,1	HB2F 90 S 4	1410	7,4	3	0,7	75,2	74,7	70	2,6	2,9	4,4	0,0025	BF 14	16	5000	17
1,5	HB2F 90 L 4	1410	10,2	3,9	0,71	77,2	79	74,5	3,2	3,6	5,2	0,0037	BF 05	27	4000	23
1,85 *	HB2F 90 LB 4	1400	12,6	4,5	0,76	78,6	80	77,1	2,9	3,2	5,1	0,004	BF 05	27	4000	24
2,2 *	HB2F 90 LC 4	1400	15	5,7	0,7	79,7	80,3	77,2	2,8	3,2	4,9	0,0045	BF 05	40	3150	25
2,2	HB2F 100 LA 4	1420	14,8	5,1	0,78	80	80,8	79,2	2,7	3,2	5,1	0,0054	BF 15	40	3150	27
3	HB2F 100 LB 4	1425	20,1	6,9	0,76	82,8	83,7	82	2,8	3,2	5,5	0,0072	BF 15	40	3150	31
4	HB2F 112 M 4	1430	26,7	9,2	0,75	83,4	84,1	82,6	3	3,4	6	0,0117	BF 06S	60	2500	40
5,5 *	HB2F 112 MC 4	1420	37	12,3	0,76	84,7	86,1	85,7	3	3,4	6,1	0,0139	BF 06S	60	1800	43
5,5	HB2F 132 S 4	1450	36,2	12,2	0,76	86,3	86,9	85,7	3,2	3,4	6,3	0,0245	BF 06	75	1800	57
7,5	HB2F 132 M 4	1450	49,4	15,8	0,79	87,1	87,7	86,5	3,4	3,6	7	0,0342	BF 07	100	1250	68
9,2 *	HB2F 132 MB 4	1450	61	19,5	0,77	88	89,4	87,6	3,5	3,8	7,2	0,0399	BF 07	150	1060	74
11 *	HB2F 132 MC 4	1450	72	23	0,78	87,8	88,2	87	3,5	3,8	7,3	0,0455	BF 07	150	900	80
11	HB2F 160 SC 4	1450	72	23	0,78	87,8	88,2	87	3,5	3,8	7,3	0,0455	BF 07	150	900	89

Efficiency value not complying with IE3 class range (IEC 60034-30); nominal power and name plate referred to S3 70% intermittent duty.

*) Power or motor power-to-size correspondence not according to standard.

□ Temperature rise class F.

Technical data 400V 50Hz

4 poles - 1500 min⁻¹
 IP 55
 IC 411
 Insulation class F
 Temperature rise class B

IE3
400V - 50Hz
ErP

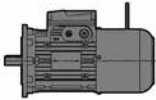

P _N kW	Motor	n _N min ⁻¹	M _N N m	I _N A 400 V	cos φ	η IE3 IEC 60034-2-1			M _S / M _N	M _{max} / M _N	I _S / I _N	J ₀ kg m ²	Brake M _f		z ₀ starts/h	kg
						100%	75%	50%					N m			
0,75	HB3F 80 B 4	1410	5,1	2	0,67	82,5	82,2	80,1	3,2	3,3	5,3	0,002	BF 04	11	6800	16
1,1	HB3F 90 S 4	1420	7,4	2,4	0,80	84,1	84,8	83,6	3,0	3,5	6,4	0,0043	BF 14	16	3150	22,5
1,5	HB3F 90 L 4	1430	10,1	3,3	0,78	85,3	86,1	85	3,1	3,7	6,7	0,0047	BF 05	27	3000	26
1,85 ¹⁾	HB3F 90 LB 4	1425	12,4	4,3	0,73	86	85,3	83,4	3,4	3,7	6,4	0,0047	BF 05	27	3000	26
2,2	HB3F 100 LA 4	1440	14,6	4,8	0,76	86,7	87,2	85,5	3,5	4,4	7,4	0,008	BF 15	40	3000	33
3 *	HB3F 112 MA 4	1450	19,8	6,1	0,80	88,7	88,6	87,3	3,5	4,4	8,8	0,013	BF 15	40	2000	40
4	HB3F 112 M 4	1450	26,3	8,5	0,77	88,6	89,2	88	3,7	4,6	9,0	0,015	BF 06S	60	1800	45,5
5,5	HB3F 132 S 4	1470	35,8	12	0,74	89,6	89,5	87,6	4,5	5,0	9,1	0,0367	BF 06	75	900	70
7,5	HB3F 132 M 4	1460	49	15,2	0,79	90,4	90,4	89,6	3,9	4,2	8,4	0,0454	BF 07	100	900	80,5
9,2 *	HB3F 132 MB 4	1460	60,2	19,2	0,76	91	90,8	90,1	4,0	4,1	8,5	0,047	BF 07	150	800	83

*) Power or motor power-to-size correspondence not according to standard.

1) Available only for 50Hz voltages

5.6

Technical data 400V 50Hz

6 poles - 1000 min⁻¹

IP 55

IC 411

Insulation class F

Temperature rise class B

IE2 P_N 0,12 ... 0,55 kW

P_N ≥ 0,75 kW S3 70%

400V - 50Hz

ErP

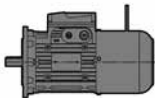

P _N kW	Motor	n _N min ⁻¹	M _N N m	I _N A 400 V	cos φ	η IEC 60034-2-1			M _S / M _N	M _{max} / M _N	I _S / I _N	J ₀ kg m ²	Brake M _f N m	z ₀ starts/h	
						100%	75%	50%							
0,09	HBF 63 A 6	900	0,95	0,48	0,57	47,6	43,1	34,4	2,5	2,6	2,3	0,0004	BF 12 1,75	12500	5,7
0,12	HB2F 63 B 6	900	1,27	0,55	0,59	52,2	48,3	40,1	2,7	2,8	2,5	0,0005	BF 12 3,5	12500	6,1
0,15 *	HB2F 63 C 6	875	1,64	0,62	0,64	55,6	53,2	46	2,5	2,5	2,6	0,0006	BF 12 3,5	11800	6,7
0,18	HB2F 71 A 6	900	1,91	0,66	0,67	59,5	57,1	49,8	2,4	2,4	3	0,001	BF 53 5	11200	8,4
0,25	HB2F 71 B 6	900	2,64	0,88	0,67	61,8	59,7	52,9	2,5	2,7	3,3	0,0013	BF 53 5	11200	9,2
0,37 *	HB2F 71 C 6	895	3,95	1,2	0,69	67,6	66,1	61	2,6	2,3	3,5	0,0018	BF 53 4,5	10000	-
0,37	HB2F 80 A 6	910	3,9	1,2	0,67	67,6	64	57,8	2,7	2,6	3,6	0,0021	BF 04 11	9500	12
0,55	HB2F 80 B 6	930	5,6	1,6	0,67	73,1	72,2	67,7	3	3	4,5	0,0033	BF 04 16	9000	15
0,75*	HBF 80 C 6	920	7,8	2,3	0,67	70,1	69,7	64,5	2,5	2,7	3,8	0,0033	BF 04 16	7100	15
0,75	HBF 90 S 6	920	7,8	2,2	0,68	72,1	72	67,9	2,4	2,4	3,7	0,0042	BF 14 16	7100	17,5
1,1	HBF 90 L 6	915	11,5	3,2	0,68	72,9	72	69,3	2,6	2,8	3,9	0,0059	BF 05 27	5300	23
1,5 * □	HBF 90 LC 6	910	15,7	4,3	0,68	73,8	72,5	70	2,7	2,9	4,3	0,0069	BF 05 40	5000	25
1,5	HBF 100 LA 6	930	15,4	3,9	0,73	75,5	75,4	71,6	2,8	3	4,8	0,0099	BF 15 40	3550	28
1,85 *	HBF 100 LB 6	930	19	4,9	0,71	76,6	76,2	72,1	3	3,2	5	0,0121	BF 15 40	3150	31
2,2	HBF 112 M 6	940	22,3	5,4	0,75	78,7	79,7	78,1	2,1	2,5	5,0	0,0157	BF 06S 60	2800	37
3 * □	HBF 112 MC 6	940	30,5	7,2	0,76	79,7	81,2	80,2	2,3	2,7	5,1	0,0197	BF 06S 60	2500	42
3	HBF 132 S 6	960	29,8	7,8	0,68	82,1	82,3	80,2	2,3	3	5,1	0,0305	BF 06 75	2360	54
4	HBF 132 M 6	960	39,8	9,7	0,72	83,2	83,7	81,8	2,5	3	5,7	0,0406	BF 07 100	1400	63
5,5	HBF 132 MB 6	960	55	12,9	0,73	84	84,8	83,4	2,6	3	6,3	0,0509	BF 07 150	1250	72
7,5 * □	HBF 132 MC 6	950	75	17,6	0,73	84,7	85	83,8	2,4	2,8	5,7	0,0611	BF 07 150	1000	80
7,5 □	HBF 160 SC 6	950	75	17,6	0,73	84,7	85	83,8	2,4	2,8	5,7	0,0611	BF 07 150	1000	89

Efficiency value not complying with IE3 class range (IEC 60034-30); nominal power and name plate referred to S3 70% intermittent duty.

*) Power or motor power-to-size correspondence not according to standard.

□ Temperature rise class F.

Technical data 400V 50Hz 460V 60 Hz

6 poles - 1000 min⁻¹ 50Hz
1200 min⁻¹ 60Hz

IP 55

IC 411

Insulation class F

Temperature rise class B

IE3
400V - 50Hz
460V - 60Hz
ErP

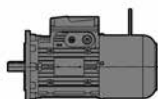

Alimen.	P _N kW	Motor	n _N min ⁻¹	M _N N m	I _N A	cos φ	η IE3 IEC 60034-2-1			M _S /M _N	M _{max} /M _N	I _S /I _N	J ₀ kg m ²	Brake M _f N m		z ₀ starts/h	
							100%	75%	50%								
Y 400 V 50 Hz 1)	0,75	HB3F 90 S 6	930	7,7	2	0,72	78,9	76	73	2,1	2,9	4,9	0,0057	BF 14 16	7100	19,5	
	1,1	HB3F 90 L 6	930	11,3	2,8	0,72	81	79	77	2,6	3	5,1	0,0071	BF 05 27	5300	26	
	1,5	HB3F 100 LA 6	950	15,1	3,5	0,75	82,5	82,4	80,4	2,5	3,4	6,5	0,0133	BF 15 40	3000	33	
	2,2	HB3F 112 M 6	960	21,9	5,1	0,73	84,3	85	83,2	2,3	3,5	6,9	0,0211	BF 06S 60	2800	43,5	
	3	HB3F 132 S 6	970	29,5	6,9	0,72	85,6	88	86,3	2,4	3,8	7,6	0,0445	BF 06 75	1400	66	
	4	HB3F 132 M 6	970	39,4	9,2	0,71	86,8	88,3	86,3	2,8	4,4	8,4	0,0611	BF 07 100	1250	80,5	
	5,5	HB3F 132 MB 6	970	54,5	12,2	0,73	88	89,3	88,7	3,2	3,4	7,2	0,0623	BF 07 150	1100	81,5	
Y 460 V 60 Hz 2)	0,75 *	HB3F 100 LA 6	1160	6,1	1,6	0,71	82,5	84,2	80,9	2,9	4,4	7,9	0,013	BF 15 13	3200	33	
	1,1 *	HB3F 112 M 6	1160	9,1	2,2	0,73	87,5	88,2	86,8	2,5	3,4	6,3	0,0215	BF 15 27	2500	41	
	1,5 *	HB3F 112 MB 6	1160	12,3	3,1	0,70	88,5	88,2	86,5	3,0	3,9	6,9	0,0215	BF 15 40	2000	41	
	2,2 *	HB3F 132 S 6	1170	18	4,3	0,72	89,5	89,9	88,4	2,7	3,6	7,3	0,0358	BF 06 50	1400	59	
	3 *	HB3F 132 M 6	1170	24,5	5,8	0,72	89,5	90,2	88,7	2,8	3,8	7,6	0,0461	BF 06 75	1000	68	
4	HB3F 132 MB 6	1170	32,6	7,9	0,70	89,5	91	89,5	3,1	4,1	8,0	0,06	BZ 07 100	800	81,5		

1) Motor Size-power combinations available with name plate at 50 Hz only (for other voltage see ch. 5.9 (1)).

2) Motor Size-power combinations available with name plate at 60 Hz only (for other voltage see ch. 5.9 (1)).

*) Power or motor power-to-size correspondence not according to standard.

5.7

Technical data 230.460V 60Hz

4 poles - 1800 min⁻¹

IP 55

IC 411

Insulation class F

Temperature rise class B

Service factor **SF 1,15**

9 terminals

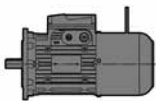

IE2 P_N 0,16 ... 0,75 hp

P_N ≥ 1 hp S3 70%

ErP

230.460V - 60Hz²⁾

NEMA MG1-12

P _N	Motor	n _N	M _N	I _N		PF	NEMA Nom. Eff. MG1-12	NEMA Code	M _S /M _N	M _{max} /M _N	I _S /I _N	J ₀	Brake	M _f	z ₀	
				A 230 V	A 460 V											
0,16 0,12	HB2F 63 A 4	1690	0,68	0,84	0,42	58	64	J	3,1	3,1	3,6	0,0003	BF 12	1,75	10000	5,5
0,25 0,18	HB2F 63 B 4	1680	1,02	1,18	0,59	60	69	J	3,3	3,1	3,8	0,0004	BF12	3,5	10000	6,1
0,33 0,25 *	HB2F 63 C 4	1690	1,42	1,5	0,75	59	72,3	J	3,5	3,5	4,2	0,0004	BF12	3,5	8000	6,9
0,33 0,25	HB2F 71 A 4	1720	1,39	1,4	0,7	65	70,9	K	2,8	3,3	4,8	0,0008	BF 53	5	8000	8,1
0,5 0,37	HB2F 71 B 4	1720	2,06	1,9	0,95	65	76	K	3,1	3,8	5,3	0,001	BF 53	5	8000	9
0,75 0,55*	HB2F 71 C 4	1720	3,06	2,6	1,3	66	78,8	K	4	4,1	6,3	0,0014	BF 53	7,5	6300	10,5
1 0,75*	HBF 71 D 4	1680	4,23	3,8	1,9	65	77	J	3,4	3,5	4,8	0,0014	BF 53	7,5	5600	10,5
0,75 0,55	HB2F 80 A 4	1740	3	2,4	1,2	74	78,4	L	3,3	3,7	7,2	0,0025	BF 04	11	6300	13
1 0,75	HBF 80 B 4	1720	4,14	3,4	1,7	70	78,5	K	3,2	3,5	6,2	0,0025	BF 04	11	5600	13
1,5 1,1*	HBF 80 C 4	1720	6,2	5	2,5	76	80	J	3,6	3,7	5,7	0,0033	BF 04	16	4000	15
1,5 1,1	HBF 90 S 4	1720	6,2	5,4	2,7	68	80	J	3	3,3	5,3	0,0025	BF 14	16	4000	17
2 1,5	HBF 90 L 4	1730	8,3	7	3,5	68	81,5	H	3,6	4,2	6	0,0037	BF 05	27	3150	23
2,4 1,85 *	HBF 90 LB 4	1710	10,4	8	4	70	84	J	3,6	4	5,6	0,004	BF 05	27	3150	24
3 2,2*	HBF 90 LC 4	1700	12,6	10	5	70	84	J	3,3	3,8	5,4	0,0045	BF 05	40	2500	25
3 2,2	HBF 100 LA 4	1730	12,3	9,2	4,6	74	85,5	J	3,1	3,7	6,1	0,0054	BF 15	40	2500	27
4 3	HBF 100 LB 4	1730	16,4	12,2	6,1	73	85,5	K	3,2	3,7	6,6	0,0072	BF 15	40	2500	31
5,4 4	HBF 112 M 4	1740	22,1	16	8	72	85,5	J	3,4	3,9	6,5	0,0117	BF 06S	60	2000	40
7,5 5,5 *	HBF 112 MC 4	1740	30,7	22,5	11,2	75	87,5	K	3,7	4,2	6,7	0,0139	BF 06S	60	1400	43
7,5 5,5	HBF 132 S 4	1750	30,5	21	10,6	74	87,5	K	3,7	3,9	7,5	0,0245	BF 06	75	1400	57
10 7,5	HBF 132 M 4	1750	40,7	27,5	13,7	77	87,5	K	3,9	4,1	7,8	0,0342	BF 07	100	1000	68
12,4 9,2	HBF 132 MB 4	1760	51	35,4	17,7	75	87,5	K	4	4,4	8	0,0399	BF 07	150	850	74
15 11	HBF 132 MC 4	1760	61	41	20,5	76,4	89,5	K	4,2	4,7	8	0,0455	BF 07	150	710	80
15 11	HBF 160 SC 4	1760	61	41	20,5	76,4	89,5	K	4,2	4,7	8	0,0455	BF 07	150	710	89

Nominal power and name plate referred to S3 70% intermittent duty.

1) The name plate contains data expressed in: hp, rpm, PF (power factor) in %.

2) Other supply on request are available, see ch. 5.9.

*) Power or motor power-to-size correspondence not according to standard.

□ Temperature rise class F.

Technical data 230.460V 60Hz

4 poles - 1800 min⁻¹

IP 55

IC 411

Insulation class F

Temperature rise class B

Service factor **SF 1,15**

9 terminals



Premium Efficiency (IE3)
230.460V - 60Hz ²⁾
EISA
 ENERGY STAR CC131B

In accordance with US DOE 10 CFR 431 and CSA C390 EISA ACT December 19, 2017

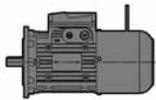

P _N		Motor	n _N	M _N	I _N		PF	NEMA Nom. Eff. MG1-12	NEMA Code	M _S /M _N	M _{max} /M _N	I _S /I _N	J ₀	Brake		z ₀	kg
1)	1)				A 230 V	A 460 V								1)	N m		
hp	kW		RPM	N m			%	%					kg m ²	N m			
1	0,75 *	HB3F 90 S 4	1740	4,1	3	1,5	73	85,5	K	3,4	4,3	7,2	0,0034	BF 14	11	3150	19,3
1,5	1,1 *	HB3F 90 L 4	1740	6,1	4,2	2,1	75	86,5	K	3,4	4,1	7,7	0,0045	BF 14	16	2500	22,3
2	1,5	HB3F 90 LB 4	1740	8,3	5,8	2,9	75	86,5	L	3,4	4,4	7,9	0,0047	BF 05	27	2500	25,2
3	2,2 *	HB3F112 MA 4	1760	12	8	4	78	89,5	M	3,9	5,1	9,6	0,0123	BF 15	40	2000	38
4	3 *	HB3F112 M 4	1750	16,3	10,6	5,3	79	89,5	M	4,1	5,4	9,4	0,0133	BF 15	40	1600	40
5,4	4	HB3F112 MB 4	1760	21,8	15	7,5	75	89,5	N	4,0	5,5	10,3	0,0149	BF 06S	60	1400	45,5
7,5	5,5 *	HB3F132 M 4	1770	29,7	19	9,5	79	91,7	L	4,1	4,4	9,7	0,0367	BF 06	75	710	70
10	7,5	HB3F132 MB 4	1760	40,6	25,8	12,9	79	91,7	L	3,7	4,4	9,1	0,0471	BF 07	100	710	83
12,3	9,2	HB3F132 MC 4	1765	49,9	33,8	16,9	74	91,7	M	4,3	4,4	8,7	0,0471	BF 07	150	710	83

1) The name plate contains data expressed in: hp, rpm, PF (power factor) in %.

2) On request other voltage are possible:

255.440V - 60Hz, 265.460V - 60 Hz and 277.480V - 60Hz.

440V (Δ) - 60 Hz, 460V (Δ) - 60 Hz e 480V (Δ) - 60 Hz.

*) Power or motor power-to-size correspondence not according to standard.

5.7

Technical data 230.460V 60Hz

6 poles - 1200 min⁻¹

IP 55

IC 411

Insulation class F

Temperature rise class B

Service factor **SF 1,15**

9 terminals

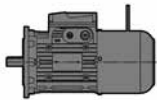

IE2 P_N 0,16 ... 0,75 hp

P_N ≥ 1 hp S3 70%

ErP

230.460V - 60Hz ²⁾

NEMA MG1-12

P _N	Motor	n _N	M _N	I _N		PF	NEMA Nom. Eff. MG1-12	NEMA Code	M _s /M _N	M _{max} /M _N	I _s /I _N	J ₀	Brake M _f	z ₀		
				A 230 V	A 460 V											1)
0,12 0,09	HBF 63 A 6	1120	0,76	0,88	0,44	52	52,5	J	2,9	3	2,7	0,0004	BF 12	1,75	10000	5,7
0,16 0,12	HB2F 63 B 6	1120	1,02	1,04	0,52	53	55,8	J	3,1	3,2	2,9	0,0005	BF 12	3,5	10000	6,1
0,20 0,15 *	HB2F 63 C 6	1100	1,3	1,2	0,6	56	58	J	3,1	3,2	3	0,0006	BF 12	3,5	9500	6,7
0,25 0,18	HB2F 71 A 6	1120	1,53	1,22	0,61	60	62,6	H	3	3,1	3,6	0,001	BF 53	5	9000	8,4
0,33 0,25	HB2F 71 B 6	1120	2,1	1,62	0,81	60	64,9	J	3,1	3,1	3,9	0,0013	BF 53	5	9000	9,2
0,5 0,37 *	HB2F 71 C 6	1120	3,16	2,2	1,1	63	70,9	J	3,2	3,3	4,5	0,0018	BF 53	7,5	8000	10,6
0,5 0,37	HB2F 80 A 6	1130	3,12	2,2	1,1	61	68,4	J	3,3	3,5	4,3	0,0021	BF 04	11	7500	12
0,75 0,55	HB2F 80 B 6	1140	4,6	3	1,5	62	75,7	K	3,6	3,7	5,3	0,0033	BF 04	16	7100	15
1 0,75 *	HBF 80 C 6	1130	6,3	4	2	62	75,5	J	2,9	3,1	4,6	0,0033	BF 04	16	5600	15
1 0,75	HBF 90 S 6	1130	6,3	3,8	1,9	66	75,5	H	2,8	3	4,5	0,0042	BF 14	16	5600	17,5
1,5 1,1	HBF 90 L 6	1130	9,4	5,6	2,8	67	75,5	H	3	3,2	4,7	0,0059	BF 05	27	4250	23
2 1,5 * □	HBF 90 LC 6	1120	12,7	7,6	3,8	64	77	J	3,1	3,3	5,2	0,0069	BF 05	40	4000	25
2 1,5	HBF 100 LA 6	1140	12,5	7	3,5	68	80	K	3,2	3,4	5,8	0,0099	BF 15	40	2800	28
2,4 1,85 *	HBF 100 LB 6	1140	15,6	8,6	4,3	68	80	K	3,4	3,6	6	0,0117	BF 15	40	2500	31
3 2,2	HBF 112 M 6	1150	18,6	9,4	4,7	72	82,5	J	2,4	2,9	6	0,0157	BF 06S	60	2240	37
4 3 * □	HBF 112 MC 6	1150	24,7	12,4	6,2	73	84	J	2,6	3,1	6,1	0,0197	BF 06S	60	2000	42
4 3	HBF 132 S 6	1160	24,5	13,8	6,9	64	85,5	K	2,6	3,4	6,1	0,0305	BF 06	75	1900	54
5,4 4	HBF 132 M 6	1160	33,1	17,2	8,6	70	85,5	K	2,9	3,4	6,9	0,0406	BF 07	100	1120	63
7,5 5,5	HBF 132 MB 6	1160	46	23	11,4	72	86,5	L	3	3,4	7,5	0,0509	BF 07	150	1000	72
10 7,5 □	HBF 132 MC 6	1150	62	31	15,5	70	86,5	K	2,7	3,2	6,9	0,0611	BF 07	150	800	80
10 7,5 □	HBF 160 SC 6	1150	62	31	15,5	70	86,5	K	2,7	3,2	6,9	0,0611	BF 07	150	800	89

Nominal power and name plate referred to S3 70% intermittent duty.

1) The name plate contains data expressed in: hp, rpm, PF (power factor) in %.

2) Other supply on request are available, see ch. 5.9.

*) Power or motor power-to-size correspondence not according to standard.

□ Temperature rise class F.

Technical data 230.460V 60Hz

6 poles - 1200 min⁻¹

IP 55

IC 411

Insulation class F

Temperature rise class B

Service factor **SF 1,15**

9 terminals



Premium Efficiency (IE3)
230.460V - 60Hz²⁾
EISA
 ENERGY STAR logo
 CC131B

In accordance with US DOE 10 CFR 431 and CSA C390 EISA ACT December 19, 2017

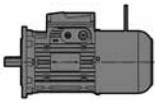

P_N		Motor	n_N	M_N	I_N			PF	NEMA Nom. Eff. MG1-12	NEMA Code	M_S/M_N	M_{max}/M_N	I_S/I_N	J_0	Brake		z_0	kg
1)					1)	A	A								%	%		
hp	kW		RPM	N m	230 V	460 V	%	%					kg m ²					
1	0,75 *	HB3F 100 LA 6	1160	6,1	3,2	1,6	71	82,5	M	2,9	4,4	7,9	0,0134	BF 15	13	3200	33	
1,5	1,1 *	HB3F 112 M 6	1160	9,1	4,4	2,2	73	87,5	J	2,5	3,4	6,3	0,0219	BF 15	27	2500	41	
2	1,5 *	HB3F 112 MB 6	1160	12,3	6,2	3,1	70	88,5	K	3,0	3,9	6,9	0,0219	BF 15	40	2000	41	
3	2,2 *	HB3F 132 S 6	1170	18	8,6	4,3	72	89,5	K	2,7	3,6	7,3	0,0368	BF 06	50	1400	59	
4	3 *	HB3F 132 M 6	1170	24,5	11,6	5,8	72	89,5	K	2,8	3,8	7,6	0,0471	BF 06	75	1000	68	
5,4	4	HB3F 132 MB 6	1170	32,6	15,8	7,9	70	89,5	L	3,1	4,1	8,0	0,0623	BF 07	100	800	81,5	

1) The name plate contains data expressed in: hp, rpm, PF (power factor) in %.

2) On request other voltage are possible:

255.440V - 60Hz, 265.460V - 60 Hz and 277.480V - 60Hz.

*) Power or motor power-to-size correspondence not according to standard.

5.8

Technical data 380V 60Hz

4 poles - 1700 min⁻¹

IP 55

IC 411

Insulation class F

Temperature rise class B

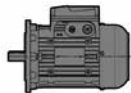

U.T.C. 1371

P _N kW	Motor			n _N min ⁻¹	M _N N m	I _N A 380 V	cos φ	η			M _S / M _N	M _{max} / M _N	I _S / I _N	J ₀ kg m ²	Brake	Mf N m	z ₀ avv./h	
								IEC 60034-2-1										
								100%	75%	50%								
0,75	HB3F	80B	4	1730	4,1	2,2	0,62	83,5	83,8	81,1	3,7	3,8	6,1	0,002	BF 04	11	5700	16
1,1	HB3F	90S	4	1735	6,1	2,6	0,77	86,5	85,5	83,3	3,3	3,7	7,5	0,0043	BF 14	16	2500	22,5
1,5	HB3F	90L	4	1740	8,3	3,7	0,75	86,5	84,0	82,5	3,4	4,4	7,9	0,0047	BF 05	27	2500	26
2,2	HB3F	100LA	4	1750	12,0	5,2	0,73	89,5	87,7	85,3	4,1	4,6	8,2	0,008	BF 15	40	2360	33
3 *	HB3F	112MA	4	1760	16,3	6,5	0,77	89,5	89,5	87,5	4,1	4,9	9,2	0,013	BF 15	40	1600	40
4	HB3F	112M	4	1760	21,8	9,0	0,75	89,5	90,2	88,7	4,0	5,5	10,3	0,015	BF 06S	60	1400	45,5
5,5	HB3F	132S	4	1770	29,7	12,8	0,71	91,7	90,2	88,2	4,6	5,2	9,8	0,0367	BF 06	75	710	70
7,5	HB3F	132M	4	1765	40,5	16,0	0,77	91,7	90,9	89,4	4,7	4,9	10,0	0,0454	BF 07	100	710	80,5
9,2 *	HB3F	132MB	4	1765	49,8	20,5	0,73	92,4	91,8	90,6	4,3	4,4	8,7	0,047	BF 07	150	710	83

* Power or motor power-to-size correspondence not according to standard.

Technical data 380V 60Hz

6 poles - 1100 min⁻¹
 IP 55
 IC 411
 Insulation class F
 Temperature rise class B

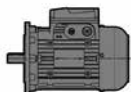

UT.C. 1371

P _N kW	Motor		n _N min ⁻¹	M _N N m	I _N A 380 V	cos φ	η IEC 60034-2-1			M _S / M _N	M _{max} / M _N	I _S / I _N	J ₀ kg m ²	Brake	Mf N m	z ₀ avv./h	kg	
							100%	75%	50%									
0,75 *	HB3F	100LA	6	1160	6,1	1,9	0,71	82,5	84,2	80,9	2,9	4,4	7,9	0,013	BF 15	13	3200	33
1,1 *	HB3F	112M	6	1160	9,1	2,6	0,73	87,5	88,2	86,8	2,5	3,4	6,3	0,0215	BF 15	27	2500	41
1,5 *	HB3F	112MB	6	1160	12,3	3,7	0,70	88,5	88,2	86,5	3,0	3,9	6,9	0,0215	BF 15	40	2000	41
2,2 *	HB3F	132S	6	1170	18,0	5,2	0,72	89,5	89,9	88,4	2,7	3,6	7,3	0,0358	BF 06	50	1400	59
3 *	HB3F	132M	6	1170	24,5	7,0	0,72	89,5	90,2	88,7	2,8	3,8	7,6	0,0461	BF 06	75	1000	68
4	HB3F	132MB	6	1170	32,6	9,5	0,70	89,5	91	89,5	3,1	4,1	8,0	0,06	BF 07	100	800	81,5

* Power or motor power-to-size correspondence not according to standard.

5.9

Motor dimensions

Mounting position
IM B5, IM B5R, IM B5...

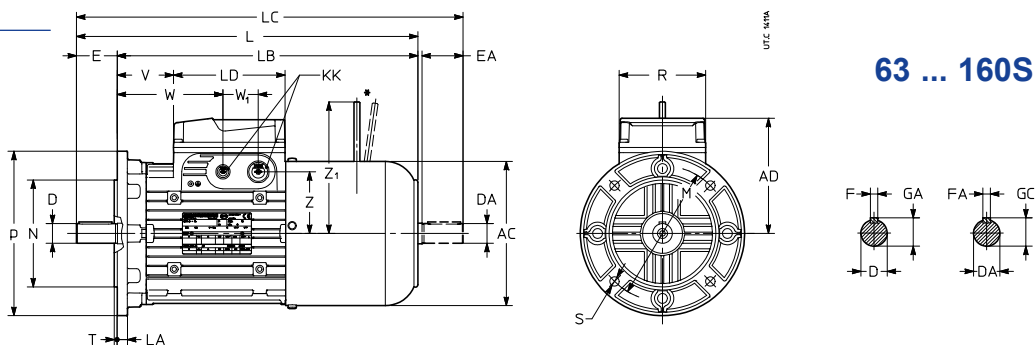

63 ... 160S

* On request

Motor size	AC	AD	L	LB	LC	LD	KK	R	V	W	W ₁	Z	Z ₁	Shaft end				Flange																
														D	1)	E	F	GA	M	N	P	LA	S	T										
	∅						2)							∅		h9		∅	∅	∅	∅													
63	B5R	123	95	281	261	306	103	4×M16	86	46	86	36	45	116	9	j6	M3	20	3	10,2	100	80	j6	120	8	7	3							
	B5A			11	j6										M4	23	4	12,5																
	B5			267	244										295	29	69	11 ³⁾	j6	M4								23 ³⁾	115	95	j6	140	10	9
71	B5B	138	112	320	297	349	2×M16 + 2×M20	66	106	47	87	62	125	11	j6	M4	23			100	80	j6	120	8	7	3								
	B5R			14	j6									M5	30	5	16	115	95								j6	140	10	9				
	B5A			308	278									344	11 ³⁾	j6	M4	23 ³⁾	4								12,5	130	110	j6	160		3,5	
	B5			301										330	14 ³⁾	j6	M5	30 ³⁾	5								16	165	130	j6	200	12	11	
	BX2			308										344																				
	BX1																																	
80	B5B	156	121	353	323	390	2×M16 + 2×M25	80	120	59	99	71	134	14	j6	M5	30			115	95	j6	140	10	9	3								
	B5R			19	j6									M6	40	6	21,5	130	110								j6	160		3,5				
	B5A			342	302									389	14 ³⁾	j6	M5	30 ³⁾	5								16	165	130	j6	200	12	11	
	B5			332	365									369																				
90 S ⁵⁾	B5S	176	141	387	357	424	2×M16 + 2×M25	106	60	120	43	75	160 ⁴⁾	14	j6	M5	30			130	110	j6	160	10	9									
	B5B			19	j6									M6	40	6	21,5	165	130								j6	200	12	11				
	B5R			376	336									423	24	j6	M8	50	8								27							
	B5			386										443																				
90 L	B5S	176	141	417	387	454	2×M16 + 2×M25	106	60	120	43	75	160 ⁴⁾	14	j6	M5	30	5	16	130	110	j6	160	10	9									
	B5B			19	j6									M6	40	6	21,5	165	130								j6	200	12	11				
	B5R			406	366									453	24	j6	M8	50	8								27							
	B5			416										473																				
100	B5C	194	151	472	432	520	2×M16 + 2×M25	106	60	120	43	75	160 ⁴⁾	19	j6	M6	40	6	21,5	130	110	j6	160	10	9									
	B5S			24	j6									M8	50	8	27	165	130								j6	200	12	11				
	B5R			482										540	28	j6	M10	60									31							
	B5A			492										560																				
112	B5	218	163	465	405	533	2×M16 + 2×M25	106	60	120	43	75	160 ⁴⁾	28	j6	M10	60			215	180	j6	250	14	14	4								
	B5S			19	j6									M6	40	6	21,5	165	130								j6	200	12	11	3,5			
	B5R			24	j6									M8	50	8	27																	
	B5A			511										570																				
132 S, M ⁶⁾	B5S	257	194	501	461	550	2×M16 + 2×M32	148	113	201	55	109	203 ⁴⁾	19	j6	M6	40	6	21,5	165	130	j6	200	12	11	3,5								
	B5R			24	j6									M8	50	8	27																	
	B5A			511										570	28	j6	M10	60									31							
	B5			521										590																				
	B5			495	435									564	38	k6	M12	80	10								41	215	180	j6	250	14	14	4
132 MA ⁸⁾ ... MCB5S	B5S	257	194	578	528	637	2×M16 + 2×M32	148	113	201	55	109	203 ⁴⁾	24	j6	M8	50		27	165	130	j6	200	12	11	3,5								
	B5B			28	j6									M10	60		31																	
	B5R			608										697	38	k6	M12	80	10								41	215	180	j6	250	14	14	4
	B5A			573	493									662																				
	B5			573										662	78	166																		
132 MA ⁸⁾ ... MCB5S	B5S	257	194	638	588	697	2×M16 + 2×M32	148	113	201	55	109	203 ⁴⁾	24	j6	M8	50	8	27	165	130	j6	200	12	11	3,5								
	B5B			28	j6									M10	60		31																	
	B5R			648										717	38	k6	M12	80	10								41	215	180	j6	250	14	14	4
	B5A			668										757																				
160 S	B5	257	194	633	553	722	2×M16 + 2×M32	148	113	201	55	109	203 ⁴⁾	42	k6	M16 ⁷⁾	110 ⁷⁾	12 ⁷⁾	45 ⁷⁾	300	250	h6	350	15	18	5								
	B5			682	572									771	157	245																		

1) Tapped butt-end hole.

2) Prearranged for cable entry knockout openings on both sides (two openings on each side).

3) Shaft end not according to standard.

4) Dimension valid for motor-brake pairing 90-BF05 and 112-BF06S; 132-BF06 and 160-BF07 with brake of smaller size Z₁ of smaller motor size.

5) For motors HB3F 90S2 and HB3F 90S 4 dimensions are ones of sizes 90L.

6) For motors HB3F 132SB 2, HB3F 132SC 2, HB3F 132S 4, HB3F 132M 4 and HB3F 132M 6 dimensions are ones of sizes 132 MA ... MC.

7) Second shaft dimensions as size 132.

8) For motor HBF 132MA 2 dimensions are the ones of size 132S, M.

Mounting position
IM B14, IM B14R

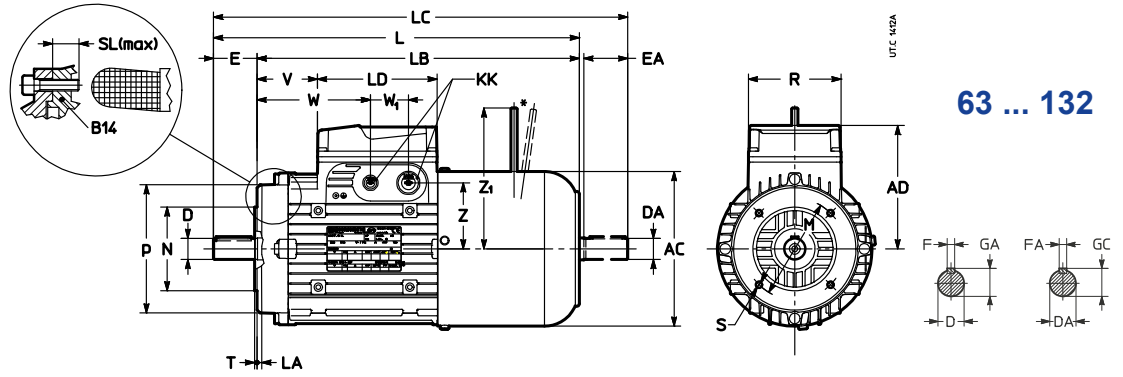

* On request

Motor size	AC	AD	L	LB	LC	LD	KK	R	V	W	W ₁	Z	Z ₁	Shaft end				Flange										
														D	1)	E	F	GA	M	N	P	LA	S	SL	T			
	∅						2)							∅	h9	∅	∅	∅	∅	∅	max							
63	B14	123	95	267	244	295	103	4×M16	86	29	69	36	45	116	11	j6 M4	23	4	12,5	75	60	j6	90	8	M5	10	2,5	
71	B14R B14	138	112	301 308	278	330 344		2×M16 + 2×M20		47	87		62	125	14	j6 M5	30	5	16	85	70	j6	105	8	M6		2,5	
80	B14R B14	156	121	332 342	302	369 389				59	99		71	134	19	j6 M6	40	6	21,5	100	80	j6	120	8	M6		3	
90 S⁶⁾	B14	176	141	386	336	443	136	2×M16 + 2×M25	106	39	99	43	75		24	j6 M8	50	8	27	115	95	j6	140	10	M8		12	
90 L	B14			416	366	473				69	129		160 ³⁾															
100	B14	194	151	465	405	533				82	142		86		28	j6 M10	60	8	31	130	110	j6	160	10	M8		13	3,5
112	B14	218	163	495	435	564				100	160		98	198 ³⁾														
132 S, M⁷⁾	B14	257	194	573	493	662	190	2×M16 + 2×M32	148	78	166	55	109	203 ³⁾	38	k6 M12	80	10	41	165	130	j6	200	8	M10		18	
132 MA⁸⁾ ... MC B14				633	553	722				138	226		226 ³⁾															

1) Tapped butt-end hole.

2) Prearranged cable entry knockout openings on both sides (two openings on each side);

3) Dimension valid for motor-brake pairing 90-BF05 and 112-BF06S, 132-BF06 and 160-BF07; with brake of smaller size Z₁ of smaller motor size.

6) For motors **HB3F 90S2** and **HB3F 90S 4** dimensions are the ones of sizes 90L.

7) For motors **HB3F 132SB 2**, **HB3F 132SC 2**, **HB3F 132S 4**, **HB3F 132M 4** and **HB3F 132M 6** dimensions are the ones of sizes 132 MA ... MC.

8) For motor **HBF 132MA 2** dimensions are the ones of size 132S, M.

Mounting position
IM B3

63 ... 160S

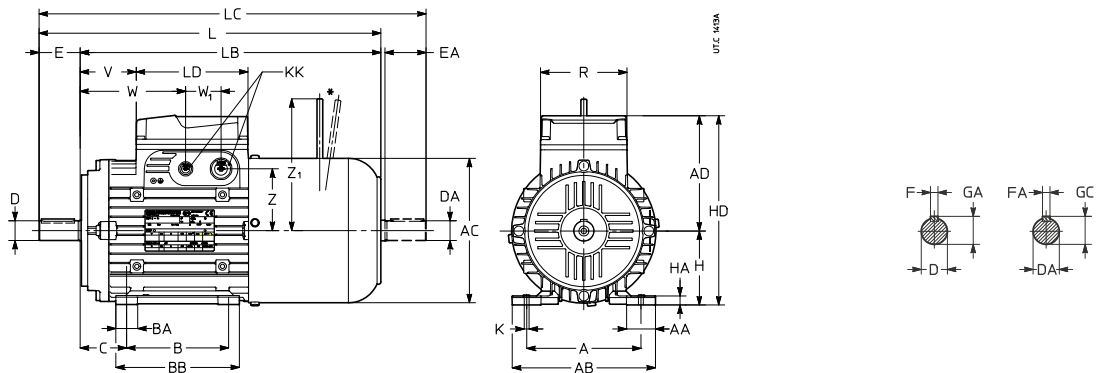

* On request

Motor size	AC	AD	L	LB	LC	LD	KK	R	V	W	W ₁	Z	Z ₁	Shaft end				Feet																	
														D	DA	1)	E	F	GA	GC	A	AB	B	C	BB	BA	AA	K	HA	H ⁴⁾	HD				
63	B3	123	95	267	244	295	103	86	29	69	36	45	116	11	j6	M4	23	4	12,5	100	120	80	40	100	21	27	7	9	63	158					
71	B3	138	112	308	278	344	2×M16 + 2×M20	-	47	87	-	62	125	14	j6	M5	30	5	16	112	138	90	45	110	22	28	9	10	71	183					
80	B3	156	121	342	302	389			59	99		71	134	19	j6	M6	40	6	21,5	125	152	100	50	125	26	35		11	90	230					
90 S⁶⁾	B3	176	141	386	336	443	136	2×M16 + 2×M25	106	39	99	43	75	24	j6	M8	50	8	27	140	174	56	150	35	11		90				230				
90 L	B3			416	366	473			69	129		160 ³⁾																							
100	B3	194	151	465	405	533	190	2×M16 + 2×M32	82	142	-	86	28	j6	M10	60	8	31	160	196	140	63	185	40	37	12	12	100	251						
112	B3	218	163	495	435	564			100	160		98							198 ³⁾										190	226	70	50	15	112	275
132 S, M⁷⁾	B3	257	194	573	493	662			148	78		166							55	203 ³⁾			38	k6	M12	80	10	41	216	257	140 ⁹⁾	89	210	42	52
132 MA⁸⁾... MC	B3			633	553	722			138	226		226 ³⁾										178 ⁹⁾													
160 S	B3			682	572	771			157	245				42	k6	M16 ⁵⁾	110 ⁵⁾	12 ⁵⁾	45 ⁵⁾	254	294	210	108	246	45		20	160	354						

- 1) Tapped butt-end hole.
- 2) Prearranged cable entry knockout openings on both sides (two openings on each side);
- 3) Dimension valid for motor-brake pairing 90-BF05 and 112-BF06S, 132-BF06and 160-BF07; with brake of smaller size Z₁ of smaller motor size.
- 4) Tolerance $0_{-0.4}$.
- 6) For motors **HB3F 90S2** and **HB3F 90S 4** dimensions are the ones of sizes 90L.
- 7) For motors **HB3F 132SB 2**, **HB3F 132SC 2**, **HB3F 132S 4**, **HB3F 132M 4** and **HB3F 132M 6** dimensions are the ones of sizes 132 MA ... MC.
- 8) For motor **HBF 132MA 2** dimensions are the ones of size 132S.
- 9) Foot of 132S also has a centre distance of 178 mm and the one of size 132MA ... MC has also a centre distance of 140 mm.

Non-standard designs and accessories

Ref.	Description	Non-standard design code
(1)	Non-standard motor supply	-
(3)	Insulation class H	,H
(7)	Design for low temperatures (-30 °C)	,BT
(8)	Condensate drain holes	,CD
(9)	Additional winding impregnation	,SP
(13)	Anti-condensation heater	,S
(14)	Terminal box on one side (IM B3 and derivatives, 90 ... 160S)	,P...
(16)	Second shaft end	,AA
(17)	Axial independent cooling fan	,V...
(18)	Axial independent cooling fan and encoder	,V... ,E...
(19)	Thermistor type thermal probes (PTC)	,T15
(20)	Bi-metal type thermal probes	,B15
(21)	Drip-proof cover	,PP
(25)	Lever for manual release with automatic return	,L
(35)	Light alloy fan	,VL
(36)	Encoder	,E1 ... ,E5
(42)	Motor certified to UL	,UL
(47)	Design for damp and corrosive environment, stainless steel brake disc, bolts	,UC, DB
(48)	IP 56 protection	,IP56
(49)	IP 65 protection	,IP65
(61)	Manual rotation	,MM
(62)	Motor prearranged for encoder	,PE
(63)	Axial independent cooling fan and prearranged for encoder	,V... ,PE...

(1) Non-standard supply of motor and brake

The first two columns show the possible types of supply.

Supply values of brake and independent cooling fan, if any are **co-ordinated** with motor winding voltage as stated in the table.

Motor wound and stated for		Operational details				
		Supply		Motor type		
		V	Hz	Brake	HBF	HB2F
± 5%		V ~ ± 5%	Hz			
Δ220 Y380	50	Δ220 Y380	50	○	○	○
Δ230 Y400	50	Δ230 Y400	50	●	●	●
Δ265 Y460	60	Δ277 Y480	60	●	●	●
Δ277 Y480	60	Δ277 Y480	60	○	●	●
Δ240 Y415	50	Δ240 Y415	50	○	○	○
YY230 Y460	60	YY230 Y460	60	○	○	○
Δ400	50	Δ230 Y400	50	○	○	○
Δ480	60	Δ277 Y480	60	○	○	○
Δ255 Y440	60	Δ255 Y440	60	○	○	○
Δ415	50	Δ240 Y415	50	○	○	○
Δ440	60	Δ255 Y440	60	○	○	○
Δ460	60	Δ265 Y460	60	○	○	○
Δ220 Y380	60	Δ220 Y380	60	○	○	○
Δ380	60	Δ220 Y380	60	○	○	○
Δ290 Y500	50	Δ290 Y500	50	○	○	○
Δ346 Y600	60	Δ346 Y600	60	○	○	○

● standard ○ on request

For different voltage values consult us.

Designation: by following instructions at ch. 5.2, state **voltage** and **frequency** (in the first table columns).

(3) Insulation class H

Insulation materials in class H with permissible temperature rise in class H.

Non-standard design code for the **designation: ,H**

(7) Design for low temperatures (-30 °C)

Standard motors can operate for possible ambient temperature down to -15 °C.

For ambient temperature down to -30 °C: special bearings, light alloy fan (in addition also cable glands and metal plugs, if supply is foreseen).

If there are dangers of condensate, it is advisable to require also the design «Design for damp and corrosive environment» (47), «Condensate drain holes» (8) and/or «Anti-condensation heater» (13).

May there be dangers of ice on friction surface consult us.

With designs (17), (18), (36) and (63) consult us.







Non-standard design code for the **designation: ,BT**

(8) Condensate drain holes

It is advisable for motors operating in particularly damp environments and/or with wide variation in the temperature and/or at low temperature. In motor designation state in «MOUNTING POSITION» the designation of the real application mounting position, determining the hole position.

Motors are supplied with closed holes.

Non-standard design code for the **designation: ,CD**

Mounting position						
IM						
B3	IM 1001	IM 1011	IM 1031	IM 1051	IM 1061	IM 1071
B5	IM 3001	IM 3011	IM 3031	IM 3051	IM 3061	IM 3071
B14	IM 3601	IM 3611	IM 3631	IM 3651	IM 3661	IM 3671
B3-B5	IM 2001	IM 2011	IM 2031	IM 2051	IM 2061	IM 2071
B3-B14	IM 2101	IM 2111	IM 2131	IM 2161	IM 2161	IM 2171
B3 ,AA	IM 1002	IM 1012	IM 1032	IM 1052	IM 1062	IM 1072
B5 ,AA	IM 3002	IM 3012	IM 3032	IM 3052	IM 3062	IM 3072
B14 ,AA	IM 3602	IM 3612	IM 3632	IM 3652	IM 3662	IM 3672

(9) Additional windings impregnation

It consists of a second impregnation cycle after stator winding assembly (standard with designs (47), (48)).

Useful where it is necessary to have an additional protection (of the windings) against electrical stress (voltage peaks due to rapid commutations or to «low quality» inverters with high voltage gradients) or mechanical agents (mechanical or electromagnetic vibrations: e.g. from inverter). See also ch. 2.9 «Voltage peaks (U_{max}), voltage gradients (dU/dt), cable length».

Non-standard design code for the **designation: ,SP**

(13) Anti-condensation heater

It is advisable for motors operating in particularly damp environments and/or with wide variation in the temperature and/or at low temperature; single-phase supply 230 V a.c. $\pm 10\%$ 50 or 60 Hz (other voltage on request); power absorbed: 15 W for sizes 63 and 71, 25 W for sizes 80 ... 100, 50 W for sizes 112 ... 160. Heater must not be connected during the running.

Non-standard design code for the **designation: ,S**

(14) Terminal box on one side for IM B3 and derivatives (sizes 90 ... 160S)

Terminal box in position P1 or P2.

Non-standard design code for the **designation: ,P...** (additional code 1 or 2 according to scheme beside).

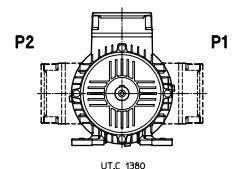

(16) Second shaft end

For dimensions s. ch. 5.8; radial loads are not permissible.

Not possible with designs (17), (18), (36), (62) and (63).

Non-standard design code for the **designation: ,AA**

(17) Axial independent cooling fan

Cooling provided with **compact** axial independent cooling fan, for variable speed drives (motor can absorb nominal current for all speed range, in continuous duty cycle and without overheating) with inverter and/or for heavy starting cycles (for z_0 increases consult us).

LB dimension (see ch. 5.8) increases by ΔLB quantity stated in the following table.

Specifications of independent cooling fan:

- 2 poles motor;
- **IP 54** protection (it is the protection stated on name plate);
- supply terminals on relevant: auxiliary inside the motor terminal box;
- other data according to the following table.

Non-standard design code for the **designation: ,VA ,VD ,VF**.

IC 416 is stated on name plate.

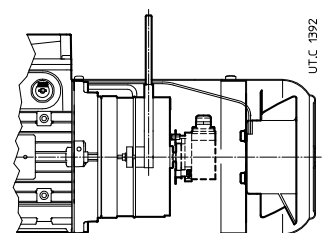

Motor size woun and stated for			Independent cooling fan name plate				Independent cooling									
Motor size	V	Hz	V	Hz	W	A	kg	Code	Type	ΔLB						
63 ... 80	Δ220 Y380	50	230	50/60	19/18	0,12/0,11	0,4	,VA	Single phase	81 (Size 63)	68 (Size 71)	73 (Size 80)				
	Δ230 Y400	50														
	Δ265 Y460	60														
	Δ277 Y480	60														
	Δ240 Y415	50														
	YY230 Y460	60														
	Δ400	50														
	Δ480	60														
	Δ255 Y440	60														
	Δ415	50														
	Δ440	60														
	Δ460	60														
	Δ220 Y380	60														
	Δ380	60														
	Δ290 Y500	50														
Δ346 Y600	60															
90	Δ220 Y380	50	230	50/60	45/39	0,31/0,25	0,9	,VA	Single phase	88						
	Δ230 Y400	50														
	Δ265 Y460	60														
	Δ277 Y480	60														
	Δ240 Y415	50														
	YY230 Y460	60														
	Δ400	50														
	Δ480	60														
	Δ255 Y440	60														
	Δ415	50														
	Δ440	60														
	Δ460	60														
	Δ220 Y380	60														
	Δ380	60														
	Δ290 Y500	50														
Δ346	600															
100,112	Δ220 Y380	50	Y380	50	40	0,12		,VD	Three phase	78						
	Δ230 Y400	50											Y400	50	45	0,13
	Δ265 Y460	60											Y460	60	45	0,13
	Δ277 Y480	60											Y480	60	50	0,15
	Δ240 Y415	50											Y415	50	45	0,13
	YY230 Y460	60											Y460	60	45	0,13
	Δ400	50											Y400	50	45	0,13
	Δ480	60											Y480	60	50	0,15
	Δ255 Y440	60											Y440	60	43	0,12
	Δ415	50											Y415	50	45	0,13
	Δ440	60											Y440	60	43	0,12
	Δ460	60											Y460	60	45	0,13
	Δ220 Y380	60											Y380	60	38	0,11
	Δ380	60											Y380	60	38	0,11
	Δ290 Y500	50											Y500	50	45	0,1
132,160S	Δ220 Y380	50	Y380	50	40	0,12	1,7	,VD	Three phase	81						
	Δ230 Y400	50											Y400	50	45	0,13
	Δ265 Y460	60											Y460	60	45	0,13
	Δ277 Y480	60											Y480	60	70	0,15
	Δ240 Y415	50											Y415	50	51	0,16
	YY230 Y460	60											Y460	60	65	0,14
	Δ400	50											Y400	50	53	0,15
	Δ480	60											Y480	60	70	0,15
	Δ255 Y440	60											Y440	60	60	0,14
	Δ415	50											Y415	50	51	0,16
	Δ440	60											Y440	60	60	0,14
	Δ460	60											Y460	60	65	0,14
	Δ220 Y380	60											Y380	60	56	0,12
	Δ380	60											Y380	60	56	0,12
	Δ290 Y500	50											Y500	50	53	0,12
								,VF								

(18) Axial independent cooling fan and encoder

Independently cooled motor equipped with hollow shaft encoder with elastic fastening for brake air-gap adjustment.

For specifications and designation code relevant to the independent cooling fan and the encoder see designs (17) and (36), respectively.

Motor overall dimensions as «Axial independent coling fan» (17).

Non-standard design code for the **designation: ,V ... ,E...**

IC 416 is stated on name plate.

(19) Thermistor type thermal probes (PTC)

Three thermistors wired in series (to DIN 44081/44082), inserted in the windings, for connection to a suitable contact breaker device. A sharp variation in resistance occurs when (delay 10 ÷ 30 s) the temperature of the windings reaches the setting temperature of **150 °C (T15)**.

With design (3) «Insulation class H» if required, **thermistors** with setting temperature of 170 °C (**T17**) are supplied.

Terminals connected to a loose or fixed terminal block inside the terminal box.

Non-standard design code for the **designation: ,T15**

(20) Bi-metal type thermal probes

Three bi-metal probes wired in series with usually closed contact inserted in the windings. Nominal corrent 1,6 A, nominal voltage 250 V a.c.. The contact opens when (delay 20 ÷ 60 s) the temperature of the windings reaches the setting temperature of **150 °C (B15)**.

With design (3) «Insulation class H» if required, **bi-metal probes** with setting temperature of 170 °C (**B17**) are supplied.

Terminals connected to fixed or loose terminal block inside the terminal box.

Non-standard design code for the **designation: ,B15**

(21) Drip-proof cover

Necessary design for outdoor applications or when water sprays are present, in mounting position with downwards vertical shaft (IM V5, IM V1, IM V18).

LB dimension (see. ch. 5.8) increases by $\Delta LB = 25$ mm.

Non-standard design code for the **designation: ,PP**

(25) Lever for manual release with automatic return

Three-phase motors sizes 63 ... 160S equipped with lever for manual release with automatic return and removable lever rod; position of release lever corresponding to terminal box as per schemes.

Non-standard design codes for the **designation: ,L ,L1 (90°) ,L2 (270°) ,L3 (180°)**.

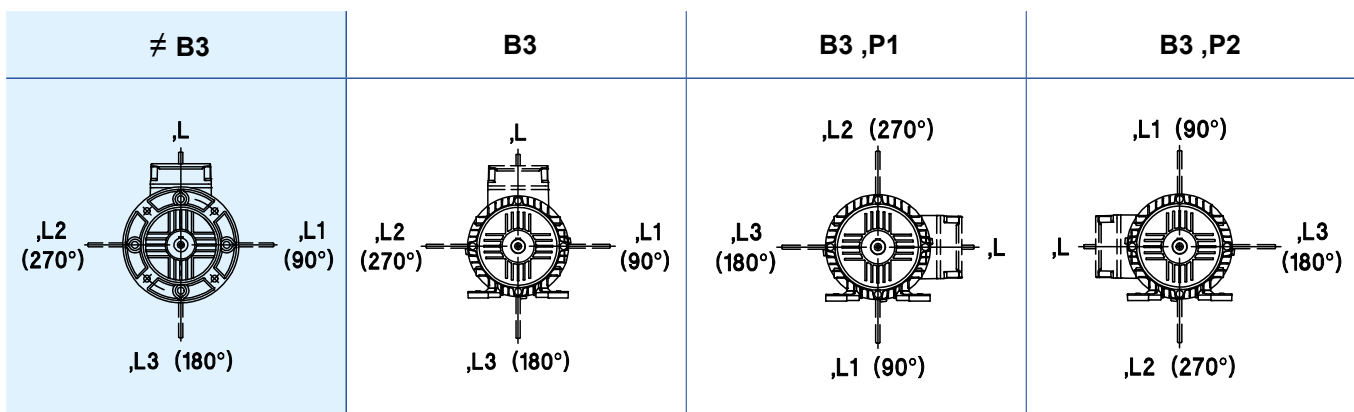

(35) Light alloy fan

Motor with light alloy fan (aluminum) for environments where it is not advisable to use the standard plastic fan.

Non-standard design code for the **designation: ,VL**

(36) Encoder

Motor equipped with incremental hollow shaft encoder and elastic fastening with the following features stated in the table (free connection wirings for the use of connectors installed by the Buyer).

For different and/or additional technical specifications, consult us.

LB dimensions (see ch. 5.8) **increases** by ΔLB quantity stated in the table.

Non-standard design code for the **designation**: ,E1 ... ,E5 (see table).

Size	Encoder ΔLB [mm] ,E1 ... ,E5
63	54
71	55
80	60
90	56
100	44
112	50
132, 160S	42

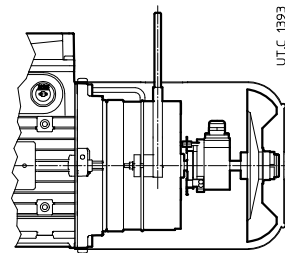

Output signal ¹⁾	RS 422 LD TTL	RS 422 TTL	Push - Pull HTL LD HTL	sin / cos	
Supply voltage U_B	5 V d.c. \pm 5%	10 \div 30 V d.c.		5 V d.c. \pm 5%	10 \div 30 V d.c.
Maximum current consumption (without load) I_N	90 mA		100 mA	110 mA	
Channels	A+, A-, B+, B-, 0+, 0-				
Output amplitude per track	$U_l \leq 0,5 V_{dc}$; $U_h \geq 2,5 V_{dc}$		$U_l \leq 0,5 V_{dc}$; $U_h \geq U_B - 1 V_{dc}$	1 $V_{PP} \pm 20\%$ (channel A, B) 0,1 \div 1,2 V (channel 0)	
Maximum output current per track I_{out}	± 20 mA		± 30 mA	-	
Maximum pulse frequency f_{max}	100 \div 300 kHz ^{2) 3)}			-	
Frequency -3 dB	-			≥ 180 kHz	
No. pulse per revolution	1024 ⁴⁾				
Vibration resistance (DIN-IEC 68-2-6)	≤ 100 m/s ² , 10 ... 2000 Hz				
Shock resistance (DIN-IEC 68-2-27)	$\leq 1000 \div 2500$ m/s ² , 6 ms ²⁾			≤ 2000 m/s ² , 6 ms	
Maximum speed	6000 min ⁻¹				
Ambient temperature	-40 °C \div 100 °C	-30 °C \div 85 °C	-40 °C \div 100 °C	-25 °C \div 85 °C	
Protection degree (EN 60 529)	IP65				
Connections	cavi liberi ⁸⁾ L = 1000 mm for use of connector installed by the user				
Encoder cable cross-sections	2x0,22+6x0,14 [mm ²]	10x0,14 [mm ²]	2x0,22+6x0,14 [mm ²]	8x0,22 [mm ²]	8x0,22 [mm ²]
Code for designation	,E1	,E2	,E3	,E4	,E5

1) Other electronic configurations available on request; consult us.

2) Variable depending on the model.

3) Parameter to be checked depending on the combination max motor speed/pulse per revolution required.

4) Other pulse rates available on request (max 5 000 ppr).

8) On request: different cable lengths, output with connector or with connector and cable; consult us.

(42) Motor certified to UL

Motor certified (≤ 750 V, 50/60 Hz) both to UL1004-1 and CAN/CSA 22.2 No.100-14, for USA and Canada markets respectively, and electrically complying with to NEMA Standard Publication MG 1-12 2009.

The main variations of this product are:

- approved UL class F insulation winding system;
- approved UL terminal block terminal assignment according to NEMA;
- cooling fan made of aluminium or certified thermoplastic material;
- certified and marked cables;
- verification and adjustment of air distances toward ground and between live parts;
- name plate with logo , showing only the data relating to the supply required in the order.
- for motor with $P_N \geq 1$ hp (motor with EISA Premium Efficiency class excluded) are available with intermittent duty cycle S3 70%.

Standard for 230YY 460Y V, 60 Hz motor supply and for motor with efficiency EISA Premium Efficiency class.

Non-standard design code for the **designation**: ,UL.

(47) Design for damp and corrosive environment

Advised for outdoor installation, in presence of humidity, in case of condensate dangers, especially for aggressive environment, including design «Additional winding impregnation» (9) and anti-oxidation paint of stator, rotor and shaft.

Brake with dragging hub and brake plate (end-shield end) made of stainless steel.

In these cases it is recommended to require also the design «Condensate drain holes» (8) and/or «Anti-condensation heater» (13).

For strongly aggressive environment (e.g. sea), it is possible to require: stainless steel brake disc and anti-sticking friction surface (the braking torque reduces to 0,8 times the one stated at point 5.5); stainless steel bolts and screws of brake (fastening screws, bushes and nuts). In this case the motor is to be specifically purchased with «**Stainless steel brake disc, bolts and screws**» (Further non-standard design code for the **designation**: ,DB).

With design «Axial independent cooling fan and encoder» (18) and «Encoder» (36) consult us.

Non-standard design code for the **designation**: ,UC

(48) IP 56 protection

It is recommended for motors running in presence of direct splash or bolts of water (including design (47)).

Seal between couplings surfaces of housing and endshields (to be re-adjusted when disassembling the motor).

Brake including: stainless steel dragging hub.

In these cases it is advisable to require also the design «Condensate drain holes» (8) and/or «Anti-condensation heater» (13) and «Stainless steel brake disc, bolts and screws».

Non-standard design code for the **designation**: ,IP 56

Non-standard design	63 ... 160S	
(17)	<input type="radio"/>	
(18)	<input type="radio"/>	
(36)	<input type="radio"/>	
(62)	<input checked="" type="radio"/>	
(63)	<input type="radio"/>	

○ Consult Rossi S.p.A.
● Possible

(49) IP 65 protection

Advised both for motors running in dusty environments and to avoid that wear dust of friction surface is dispersed in the environment (e.g. food industry).

Seal between the coupling surfaces of housing and endshields (to be re-adjusted when disassembling the motor).

IP 65 brake protected with: V-ring, O-rings on fastening screws of brake and on the pullers of the release hand lever.

In damp and/or aggressive environment, in case of condensate and/or mildew dangers or of long brake standstill, it is recommended to require the «Design for damp and corrosive environment» (47), if necessary also with «Stainless steel bolts and screws» (described ways in (47)).

Non-standard design code for the **designation**: ,IP 65.

Non-standard design	63 ... 160S	
(17)	<input type="radio"/>	
(18)	<input type="radio"/>	
(36)	<input checked="" type="radio"/>	
(62)	<input checked="" type="radio"/>	
(63)	<input type="radio"/>	

○ Consult Rossi S.p.A.
● Possible

(61) Manual rotation

On request, prearranged for **manual rotation** by straight setscrew (see table) that can be fitted on non-drive end motor shaft (excluding the non-standard designs «Axial independent cooling fan» and «Axial independent cooling fan and encoder» ch. 5.9 (17), (18), (63));

To be always combined with special execution 25 (level for manual release with automatic return).

Non-standard design code for the **designation: ,MM.**

Motor size	Wrench 
63, 71	5
80, 90	6
100, 112	8
132 ... 160S	10

(62) Motor prearranged for encoder

Motor prearranged for encoder with following features:

- anti-rotation center distance Ø 63 mm
- flexible anti-rotation bracket with 1 or 2 holes/slots at 180° suitable for screw passage M3;
- max encoder height 48 mm;
- motor shaft Ø 10 h6 mm

Motor dimensions as per encoder design (36).

Non-standard design code for the **designation: ,PE**

(63) Axial independent cooling fan and prearranged for encoder

Independently cooled motor prearranged for encoder with following features:

- anti-rotation center distance Ø 63 mm;
- flexible anti-rotation bracket with 1 or 2 holes/slots at 180° suitable for screw passage M3;
- max encoder height 48 mm;
- motor shaft Ø 10 h6 mm and length 35 mm.

For specifications and independent cooling fan designation code see design (17)

Motor overall dimensions as «Axial independent cooling fan» (17).

Non-standard design code for the **designation: ,V... PE**

Miscellaneous

- Asynchronous three-phase two-speed motors.
- Special paints or completely unpainted motor.
- Motor balancing according to reduced vibration degree (B) to CEI EN 60034-15.
- Motors with integral feet and flange (IM B35, IM B34 and relevant vertical mounting positions).
- Power connector.
- Sensorized drive end bearing (32, 48 or 64 pulses per revolution) for the measurement of angle and/or rotation speed (sizes 63 ... 100); for specifications and wiring schemes consult us.
- Pt 100 temperature probe.
- Encoder for high temperatures.
- Designs with supply cable.
- Design for oil seal (e.g. coupled with mechanical variator).
- Design for high temperatures.
- Brakes with different adjustment and/or of smaller or greater size.
- Special release lever rod to keep brake release condition.
- Design with adjustable braking torque.

5.11

Name plate

MOT. (1)~ (9)	(2) (3) (4) (5)	IP (6)	AMB. (7)	IC (8)			
(14)	(10)	kg (11)	I.CL. (12)	S (13)			
(15)	Brake (30)	Nm (31)	V~/Hz (32)	A (33)	#/Δ#	V=	
DE/NDE (16)							
(17)							
(19) V (19)	% (21)	Hz (22)	% (23)	A (24)	kW (25)	min ⁻¹ (26)	cos φ (27)
(20)							
(28)							
(29)							

UTC 2379

MOT.(1)~N. (9)	(10)	IP (6)	AMB.(7)	IC (8)			
(2) (3) (4) (5)		kg (11)	I.CL.(12)S (13)				
Brake (30)	Nm (31)	V~/Hz (32)	A (33)	#/Δ#	V=		
(14)		(15)		(10)			
NEMA MG1-12 SF (36)		DESIGN (29)		CODE (29)			
(19) V (19)	Hz (22)	A (24)	HP (25)	RPM (26)	PF (27)	NOM. EFF (28)	
(20)							
ENERGY		Verified for energy efficiency in accordance with US DOE 10CFR431, dated September 22, 2015					
		Verified for energy efficiency in accordance with CSA C390-10, dated March 2010, reaffirmed 2015					
CC131B						E304505	

UTC 2380

NEMA YY230 Y460 V, 60Hz

- (1) Number of phases
 - (2) Motor type
 - (3) Size
 - (4) Number of poles
 - (5) Designation of mounting position
 - (6) Protection IP ...
 - (7) Maximum ambient temperature
 - (8) Code IC
 - (9) Production number
 - (10) Two months and year of manufacturing end serial number
 - (11) Motor mass
 - (12) Insulation class I.CL....
 - (13) Duty cycle S...
 - (14) Motor code
 - (15) Customer code¹⁾
 - (16) Bearings
 - (17) Note 1
 - (18) Note 2
 - (19) Connection of the phases
 - (20) Nominal voltage
 - (21) Voltage tolerance
 - (22) Nominal frequency
 - (23) Frequency tolerance
 - (24) Nominal current
 - (25) Nominal power
 - (26) Nominal speed
 - (27) Nominal power factor
 - (28) Nominal efficiency IEC 60034-2-1
 - (29) Design - code
 - (30) Brake size
 - (31) Brake braking torque
 - (32) Brake supply
 - (33) Current absorbed by brake
 - (36) Service factor
- 1) On request.

MOT. 3 ~	HB3F 90L 4 B5	IP 55	AMB. 40°C	IC 411			
2365453	03/21 7593607	kg 25	I.CL. F	S 1			
R000175040	Brake BF05	Nm 27	V~/Hz y400-480/50-60	A 0.36	#/Δ#	V=	
DE/NDE		h g					
(17)							
Δ V Y	%	Hz	%	A	kW	min ⁻¹	cos φ
230/400		50		5.7/3.3	1.5	1430	0.78
265/460		60		5.0/2.9	1.5 SF1.15	1740	0.74
277/480		60		5.0/2.9	1.5 SF1.2	1745	0.72
50/60Hz: IE3 85.3/86.5(100%) 86.1/87.3(75%) 85/85.5(50%)							
60Hz NEMA NOM. EFF. 86.5% 2 hp DES.C CODE. L/L							

UTC 2372

MOT.3~N.1801517	06/16	IP 55	AMB. 40°C	IC 411			
HB3F 112M 4 B5		kg 33	I.CL. F S 1				
Brake BF15	Nm 40	V~/Hz Y 460/60	A 0,26	#/Δ#	V=		
R000135970		6473660					
NEMA MG1-12 SF 1,15 CONT.		DESIGN A		CODE M			
YY V Y	Hz	A	HP	RPM	PF	NOM. EFF	
230/460	60	10,6/5,3	4	1750	79%	89,5%	
ENERGY		Verified for energy efficiency in accordance with US DOE 10CFR431, dated September 22, 2015					
		Verified for energy efficiency in accordance with CSA C390-10, dated March 2010, reaffirmed 2015					
CC131B						E304505	

UTC 2171A

Standard voltage/frequency on name plate

Motors required with supply voltage $\Delta 230$ Y400V 50Hz are supplied as standard with the following voltage/frequency values stated on motor nameplate, see following table:

Motor Type	Voltage/Frequency on nameplate	Voltage/Frequency on nameplate with design ,UL (42)
HBF	230.400 50 265.460.60	230.400 50 265.460.60
HB2F	230.400 50 265.460 60 277.480 60	230.400 50 265.460 60 277.480 60
HB3F 2, 4 Poles	230.400 50 265.460 60 277.480 60	230.400 50 265.460 60 277.480 60
HB3F 6 Poles	230.400 50	230.400 50

Other voltage types are available on request as already explained in the design (1) "Non-standard motor supply", in the specific case only the required supply will be stated on nameplate.

Brake motor for specific applications HBV

Section Contents

6.1	General specifications	142
6.2	Designation	143
6.3	Specifications	143
6.4	Radial and axial loads on shaft end	147
6.5	Motor brake specifications HBV	148
6.6	Technical data 400V 50Hz	150
6.7	Technical data 230.460V 60Hz	156
6.8	Motor dimensions	158
6.9	Non-standard designs and accessories	161
6.10	Name plate	166
6.11	Standard voltage/frequency on name plate	167

6.1

General specifications

Brake motor with direct current safety brake for specific applications

63 ... 160S

Standard

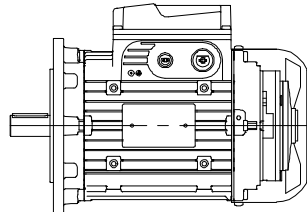

Brake motors with d.c. safety brake suitable for specific applications demanding maximum economy and compactness

Also available with **powers** (marked by*) **higher than the ones foreseen by the standards.**

Class F insulation; temperature rise class B for all motors at standard power, F for remaining motors

Mounting positions IM B5 and derivatives, IM B14 and derivatives and IM B3 (always pre-arranged) and corresponding vertical mounting positions; **mating tolerances under «accuracy» rating**

IP 55 protection

Particularly strong construction (both electrical and mechanical) to withstand alternating torsional and thermic stresses of starting and braking; duly proportioned bearings

«**Supported**» **tightening attachments** of endshields and flanges fitted on housing with «**tight**» coupling

Electromagnetic sizing especially studied to allow high acceleration capacity (high frequency of starting) and uniform starting (slightly «sagged» characteristic curves)

Suitable for operation with inverter

Asbestos-free friction surfaces

Wide metallic terminal box

Designs available for every application need

Very reduced motor overall dimensions, which are nearly the same of a non-braking motor; maximum economy

Single braking surface, fixed braking torque (usually $M_f \approx M_N$)

High braking capacity for each braking thanks to cast iron fan (or made of light alloy together with steel disc, which also acts as brake disk) especially sized in order to achieve the dissipation of high braking energies

Particularly suitable for cutting machines, safety stops, as parking brake, etc.

For standard voltages as per name plate see ch. 6.11

Designation

MOTOR	HB	asynchronous three phase
EFFICIENCY CLASS	–	$P_N \geq 0,75$ kW Duty S3 70%
	2 3	according to motor supply: - IE2 (ErP) - IE3 (ErP)
BRAKE TYPE	V	d.c. safety brake
SIZE	63 ... 160S	
NUMBER OF POLES	2, 4, 6	
SUPPLY¹⁾	230.400-50 230.460-60²⁾	Δ 230 Y400 V 50 Hz YY230 Y460 V 60 Hz
MOUNTING POSITION	B5, B14, B3, B5R, B5A, ... B14R	IM B5, IM B14 (63 ... 132), IM B3, non-standard IM B5 non-standard IM B14
Non-standard design	,... ,... ,...	code, see ch. 6.9

HB	V	80	B	2	230.400-50	B5R
HB 2	V	71	B	4	230.400-50	B5R
HB 3	V	90	L	4	230.400-50	B5 ,P2

1) May frequency and voltage differ from those stated above, see ch. 6.9 (1).

2) Motor supply for USA and Canada: includes also terminal block with 9 terminals and UL compliance (see ch. 6.9 (42)); not possible for 8 pole motors

6.3

Specifications

Electric brake motors (braking in case of failure of supply):

Asynchronous three-phase electric **brake motor** with **d.c. safety brake**, with single braking surface, with **reduced overall dimensions**, sizes **63 ... 160S**.

Standardized motor with cage rotor, totally enclosed, externally ventilated (cooling system IC 411), single-speed according to following tables:

Number of poles	Winding	Motor size	Standard supply		insulation	Class temperature rise
			50 Hz	60 Hz		
2, 4, 6	three-phase Δ Y	63 ... 160S	50 Hz	see ch. 6.11	F	B ¹⁾
4, 6	three-phase YY Y		60 Hz	YY 230 Y460 V		

1) Excluding some motors with higher power than the ones standardized (identified by □ at ch. 6.6 and 6.7) whose temperature rise class is F.

IP 55 protection: drive end with seal ring (without spring for IM B3) and non-drive end with water-proof and dust-proof O-ring
Rated power delivered on **continuous duty** (S1) and at standard voltage and frequency; ambient temperature $-15 \div 40$ °C, altitude 1000 m.

Mounting positions IM B5, IM B3 IM B14; motors can also operate in the relevant mounting positions with vertical shaft, which are respectively (see following table): IM V1 and IM V3, IM V18 and IM V19, IM V5 and IM V6; the name plate shows the designation of mounting position with horizontal shaft.

On request, other special mounting positions: consult Rossi S.p.A.

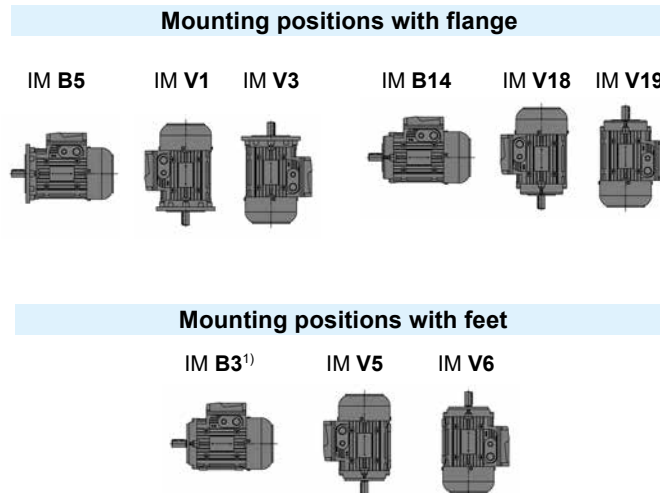

1) Motor can also operate in the mounting positions IM B6, IM B7 and IM B8; the name plate shows the IM B3 mounting position.

Main mating dimensions of the mounting positions with flange

Mounting position	Shaft end - Ø D x E Flange - Ø P								
	Motor size								
	IM	63	71	80	90	100	112	132	160S
B3	11 x 23	14 x 30	19 x 40	24 x 50	28 x 60	28 x 60	38 x 80	42 x 110	
B5	11 x 23 140	14 x 30 160	19 x 40 200	24 x 50 200	28 x 60 250	28 x 60 250	38 x 80 300	42 x 110 350	
B5R	9 x 20 120	11 x 23 140	14 x 30 160	19 x 40 200	24 x 50 200	24 x 50 200	28 x 60 250	-	
B5S	-	-	-	14 x 30 160 ¹⁾	19 x 40 200	19 x 40 200 ¹⁾	24 x 50 200 ¹⁾	-	
B5A	11 x 23 120	14 x 30 140	19 x 40 160	-	28 x 60 200	28 x 60 200	38 x 80 250	-	
B5B	-	11 x 23 120	14 x 30 140	19 x 40 160	-	-	28 x 60 200	-	
B5C	-	-	-	-	19 x 40 160	-	-	-	
B14	11 x 23 90	14 x 30 105	19 x 40 120	24 x 50 140	28 x 60 160	28 x 60 160	38 x 80 200	-	
B14R	-	11 x 23 90	14 x 30 105	-	-	-	-	-	

1) For P_N max available see tab below.

Motor size	Poles					
	2		4		6	
	$P_{N \max}$ kW [hp]					
90	1,85	[2.4]	1,1	[1.5]	0,75	[1]
112	4	[5.4]	3	[4]	1,85	[2.4]
132	9,2	[12.4]	7,5	[10]	4	[5.4]

Housing in pressure diecast light alloy; mounting position IM B3 with inserted feet which can be mounted on **three sides** (sizes 90 ... 160S).

Drive (or flange) end and **non-drive end endshield** in cast iron or light alloy (see table below).

«Supported» **tightening attachments** of endshields and flanges fitted on housing with «tight» coupling.

Ball bearings (see table) lubricated «for life» assuming pollution-free surroundings; preload spring.

Driving shaft: in steel C45, **axially fastened** on rear endshield. Cylindrical shaft ends with A-shape (rounded) key and tapped butt-end hole (see table, where: d = tapped butt-end hole; bxhxl = key dimensions).

Motor size	Endshield material and bearings	
	drive end	non-drive end
63	LL 6202 2Z	6202 2RS LL
71	LL 6203 2Z	6203 2RS LL
80	LL 6204 2Z	6204 2RS LL
90	LL 6205 2Z	6205 2RS LL
100	LL 6206 2Z	6206 2RS LL
112	LL 6306 2Z	6306 2RS LL
132	LL ¹⁾ 6308 2Z	6308 2Z G
160S	G 6309 2Z	6308 2Z G

LL = light alloy G = cast iron

1) In cast iron for IM B14 and IM B5 derivatives.

	Shaft end - Ø × E							
	Ø 9×20	Ø 11×23	Ø 14×30	Ø 19×40	Ø 24×50	Ø 28×60	Ø 38×80	Ø 42×110
d	M3	M4	M5	M6	M8	M10	M12	M16
b×h×l	3×3×12	4×4×18	5×5×25	6×6×32	8×7×40	8×7×50	10×8×70	12×8×100

Steel fan cover.

Cooling fan with radial blades made of cast iron or thermoplastic material together with aluminum disc, which also acts as brake disk

Terminal box in light alloy (integral with housing with two knockout cable openings on both sides, two openings per side one for power and one for auxiliary equipment). Pressure diecast light alloy terminal box cover. **Position opposite to feet** for mounting position IM B3; on request available on right or left side (see ch. 6.9 (14)).

Terminal block with 6 terminals (9 terminals for YY230 Y460 60 Hz voltage supply; terminal dimensions in the table above).

Motor size	Terminal block, cable entry		Seal rings
	terminals ¹⁾	cable entry ²⁾	
63	M4	4 × M16	15 × 30 × 4,5
71	M4	2 × M16 + 2 × M20	17 × 32 × 5
80	M4	2 × M16 + 2 × M20	20 × 35 × 7
90	M5	2 × M16 + 2 × M25	25 × 46 × 7
100, 112	M5	2 × M16 + 2 × M25	30 × 50 × 7
132	M6	2 × M16 + 2 × M32	40 × 60 × 10
160S	M6	2 × M16 + 2 × M32	45 × 65 × 10 ³⁾

1) 6 terminals for cable terminal connection.

2) Terminal box provided with knockout openings (cable gland not supplied).

3) Non-drive end: 40x60x10.

Earth terminal located inside terminal box; prearranged for the installation of a two further external earth terminal on housing.

Brake supply: with rectifier laying in terminal box having 2 terminals for cable connection for rectifier supply; possible brake supply **directly from** motor **terminal block** (condition of supply) or **separately** (to be used for: motors supplied by inverter, separate drive needs of motor and brake, etc.).

Pressure diecast cage **rotor** in aluminium

Stator winding with class H copper conductor insulation, insulated with double coat, type of impregnation with resin of class H; other materials are of classes F and H for a **class F insulation system**.

Rotor dynamic balancing: vibration velocity under standard rating A. Motors are balanced with half key inserted into shaft extension.

Paint: double-compound, water-soluble, polyacrylic resin based, corrosivity class C3 (to ISO 12844-2), colour blue RAL 5010 DIN 1843, unaffected by normal industrial environments and suitable for further finishings with double-compound synthetic paints.

For **non-standard designs** and accessories see ch. 6.7.

Compliance with European Directives

Motors of present catalog comply with following standards EN 60034-1, EN 60034-2, EN 60034-2-1, EN 60034-5, EN 60034-6, EN 60034-7, EN 60034-8, EN 60034-9, EN60034-12, EN 60034-14, IEC 60038, IEC 60072-1, and with **Low Voltage Directive 2014/35/EU**. For this reason the electric motors are CE marked.

Additional information:

The motor design, considering the motors as components, complies with

- Machinery Directive 2006/42/EC when the installation is correctly executed by machinery manufacturer (e.g.: in compliance with our installation instructions and EN 60204 «Electric Equipments of Industrial Machines»);
- Directive 2011/65/CE RoHS relevant to the limit of use of dangerous substances in the electric and electronic equipments.

Declaration of Incorporation (Directive 2006/42/EC Art 6.2 – II B):

The above mentioned motors must be commissioned as soon as the machines in which they have been incorporated have been declared to be in compliance with the Machinery Directive.

Radial and axial loads on shaft end

According to EN60034-1, as motors are components and not machines, supplied directly to the final user, the Electromagnetic Compatibility Directive (application of Directive 2014/30/EU, repealing the old 89/336/EC) is not directly applicable.

Radial loads generated on the shaft end by a drive connecting motor and driven machine must be less than or equal to those given in the relevant table.

The radial load F_r given by the following formula refers to most common drives:

$$F_r = \frac{k \cdot 19100 \cdot P}{n \cdot d} \text{ [N]}$$

where:

P [kW] is motor power required

n [min^{-1}] is the speed

d [m] is the pitch diameter

k is a coefficient assuming different values according to the drive type:



$k = 1$ for chain drive

$k = 1,1$ for gear pair drive

$k = 1,5$ for toothed belt drive

$k = 2,5$ for V-belt drive

The table shows maximum permissible values of radial and axial loads on driving shaft end (F_r overhung load on centre line of shaft end), calculated for a bearing life $L_n = 18000$ h. For a longer bearing life, the values stated in the table must be multiplied by: 0,9 (25000 h),

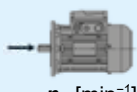
Motor size	$F_r^{1)}$ [N]				$F_a^{2)}$ [N]							
												
	n_N [min^{-1}]				n_N [min^{-1}]				n_N [min^{-1}]			
	3000	1500	1000	750	3000	1500	1000	750	3000	1500	1000	750
63	420	530	600	670	200	290	350	400	210	290	350	400
71	510	640	740	810	210	310	380	440	210	310	380	440
80	650	830	950	1050	230	350	420	500	370	500	600	680
90S	710	900	1040	1140	250	390	490	570	250	390	490	570
90L	730	930	1050	1180	240	380	480	560	240	380	480	560
100	1000 ³⁾	1300	1500	1650	300	490	620	730	370	570	710	820
112	1500 ³⁾	1900	2150	2400	660	950	1150	1310	660	950	1150	1310
132	2000 ³⁾	2500	3000	3150	1220	1650	1960	2200	1220	1650	1960	2200
160S	2500	3150	3650	4050	1720	2280	2670	2990	1220	1650	1960	2200

1) An axial load of up to 0,2 times the value in the table is permissible, simultaneously with the radial load.

2) Comprehensive of a possible unfavourable effect of weight-force of rotor and bearing preload spring.

3) For radial load value near to table limit require bearings C3.

For running at 60 Hz, table values must be reduced by 6%.

6.5

Motor brake specifications (d.c. safety brake)

63 ... 160S

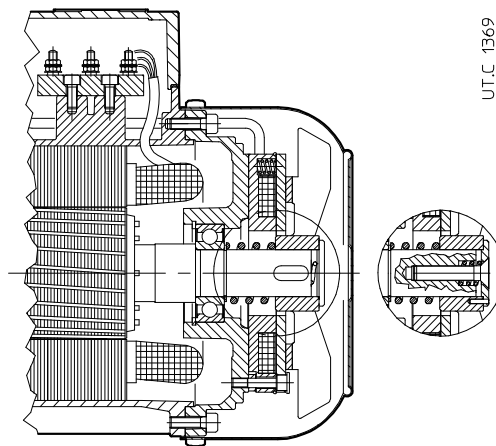

Electromagnetic spring loaded brake (braking automatically occurs when it is not supplied), with **d.c.** toroidal coil and single braking surface, **fixed braking torque** ($M_f \approx M_N$).

Conceived for **very reduced overall dimensions of motor** (nearly the same of a non-braking motor), **smooth braking** (thanks to lower rapidity, typical of d.c. brake, of brake anchor, lighter and less rapid in the impact: motor starts slightly braked and with greater progressivity), **high braking capacity for each braking** thanks to a cast iron fan (or made of thermoplastic material together with steel disc which acts as brake disk) especially sized (in order to achieve dissipation of high braking energies), **highest economy**.

Particularly suitable for cutting machines, for «**light**» **traverse movements**¹⁾, in general and for **running with inverter** at the end of deceleration ramp, for safety stops, as parking brake, etc.

1) Mechanism group M 4 (max 180 start/h) and on-load running L 1 (light) or L 2 (moderate) to ISO 4301/1, F.E.M./II 1997).

When electromagnet is not supplied, the brake anchor, pushed by springs, presses on the braking-cooling fan by generating a braking torque on the driving shaft; by supplying the brake, the electromagnet draws the brake anchor, releases the fan and the driving shaft.

Main specifications:

- **supply voltage of rectifier** (always supplied from terminal block) alternate single-phase **230 V ± 5% 50 or 60 Hz** (for Δ 230 Y 400 V 50 Hz wound); on request other voltages, see ch. 6.9 (1);
- rectifier supply **directly from motor terminal block** or indifferently from a **separate** line;
- **insulation class F, temperature rise class B**;
- **friction surface** with average friction coefficient for low wear, integral with brake anchor;
- **cast iron fan** or made of light alloy together with steel disc whose surface towards brake anchor also acts as brake disk;
- **air-gap adjustment also with mounted fan cover** through a hole with safety protection;
- possibility of **manual release of brake** through the release of the screw **45** so that fan draws away from brake anchor;
- for other functional specifications see following table;

For general motor specifications see ch. 6.3.

For non-standard designs see ch. 6.9.

Motor is **always equipped with rectifier** fixed at terminal box providing adequate connecting terminals.

Simple half-wave diodes rectifier **RN1** for **V0** brake type (output d.c. voltage $\approx 0,45$ a.c. supply voltage, maximum continuative current 1A) can be connected-disconnected both from a.c. side (for maximum reduced noise level of running) and from a.c. and d.c. side (for a quicker braking) because it is **provided with varistors to protect diodes**, electromagnet and opening contact of d.c. side (wiring schemes at ch. 7).

Simple halfwave diodes rectifier **RR1** for **VG** brake type (output d.c. voltage $\approx 0,45$ a.c. supply voltage, maximum current in connecting 2A, 1A continuative) runs with double half-wave for approx. initial 600 ms supplying to brake coil a double voltage; this allows to achieve a more rapid brake release (wiring schemes at ch. 7).

Table of main functional specifications of brake

Effective values may slightly differ according to ambient temperature and humidity, brake temperature and state of wear of friction surface.

Brake size	Motor size	$M_f \pm 12\%$	Absorption			Delay of ²⁾		Air-gap		W_1	C_{max}	$W_{fmax}^{7)}$ [J]					
			N m	Ac.c. 230 V~	A.c.c. 400 V~	W	release	braking	mm nom ⁹⁾			mm max	MJ/mm 5)	mm 6)	brakings/h		
							t_1 ms 3)	t_2 ms 4)							10	100	1000
V 02	RN1	63	2,5	0,17	0,10	18	40	100	0,25	0,50	56	2,5	3550	900	125		
V 03	RN1	71	4	0,17	0,10	18	40	100	0,25	0,60	80	2,5	5000	1250	180		
V 04, 05	RN1	80, 90	7	0,24	0,14	25	60	150	0,25	0,60	132	2,5	7500	1900	265		
V G5	RR1 ⁸⁾	90	11	0,24	0,14	25	75	118	0,25	0,60	132	2,5	7500	1900	265		
V 06	RN1	100, 112	15	0,34	0,20	35	100	250	0,30	0,65	236	2,5	12500	3150	450		
V G6	RR1 ⁸⁾	112	25	0,34	0,20	35	125	200	0,30	0,65	280	2,5	15000	3750	530		
V 07	RN1	132	30	0,58	0,34	60	150	400	0,35	0,70	375	2,5	20000	5000	710		
V G7	RR1 ⁸⁾	132,160S	50	0,58	0,34	60	190	315	0,35	0,70	375	2,5	20000	5000	710		

1) Standard rectifier.

2) Values valid with medium air-gap and nominal value of supply voltage.

3) Release time for anchor, obtained with standard rectifier.

4) Braking delay obtained by separate brake supply. With direct supply from motor terminal block the values of t_2 increase of approx. 2,5 times the ones of table.

5) Friction work for brake disk wear of 1 mm (minimum value for heavy use, real value is usually greater).

6) Maximum wear of friction surface.

7) Maximum friction work for each braking.

8) For **RR1** the **stop time** must be between **2,3 s ÷ 2,8 s**. If necessary, consult us.

9) Nominal value means approximate average value.

6.6

Technical data 400V 50 Hz

2 poles - 3000 min⁻¹

IP 55

IC 411

Insulation class F

Temperature rise class B

IE2 P_N 0,12 ... 0,55 kW

P_N ≥ 0,75 kW S3 70%

400V - 50Hz

ErP

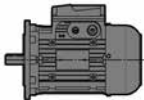

P _N kW	Motor	n _N min ⁻¹	M _N N m	I _N A 400 V	cos φ	η IEC 60034-2-1			M _S /M _N	M _{max} /M _N	I _S /I _N	J ₀ kg m ²	Brake	M _f N m	z ₀ starts/h	
						100%	75%	50%								
0,18	HB2V 63 A 2	2800	0,61	0,56	0,71	68,7	66,6	60,7	3,1	3,3	4,1	0,0005	V 02	2,5	2120	4,7
0,25	HB2V 63 B 2	2780	0,86	0,75	0,71	70,5	68,9	63,1	3,1	3,2	4,1	0,0005	V 02	2,5	2360	5,3
0,37 *	HB2V 63 C 2	2790	1,26	1,02	0,72	73,3	72,4	67,3	3,5	3,3	4,5	0,0006	V 02	2,5	2120	5,9
0,37	HB2V 71 A 2	2800	1,26	0,95	0,77	75	74,7	70,8	3,1	3,3	5,2	0,0008	V 03	4	2240	7,2
0,55	HB2V 71 B 2	2820	1,86	1,33	0,78	77,3	76,9	72,9	3,6	3,7	5,8	0,0009	V 03	4	2360	8
0,75 *	HBV 71 C 2	2830	2,53	1,85	0,79	73,8	72,9	68,7	3,5	3,7	5,7	0,001	V 03	4	1900	8,8
0,75	HBV 80 A 2	2850	2,51	1,85	0,75	78,3	77,7	74,3	3,6	3,8	6,1	0,0018	V 04	7	1600	9,5
1,1	HBV 80 B 2	2840	3,7	2,6	0,77	79,5	80,1	78,3	3,6	3,8	6,1	0,002	V 04	7	1800	10,5
1,5 *	HBV 80 C 2	2890	4,96	3,5	0,76	81,2	81,4	78,9	4	4,4	7,4	0,0022	V 04	7	1600	12,5
1,85 *	HBV 80 D 2	2820	6,3	4,2	0,8	79,8	81,2	80,1	3,7	3,8	6,2	0,0024	V 04	7	1600	13
1,5	HBV 90 S 2	2840	5	3,4	0,81	78,5	78,9	77	3	3,2	5,7	0,0025	V 05	7	1600	15
1,85 *	HBV 90 SB 2	2860	6,2	4,2	0,8	79,3	79,6	77,1	3,2	4	6,1	0,0028	V 05	7	1600	16,5
2,2	HBV 90 LA 2	2880	7,3	4,9	0,8	81	80,7	78	3,8	4,5	7	0,0031	V G5	11	2000	18,5
3 *	HBV 90 LB 2	2870	10	6,6	0,8	82	82,2	80,1	3,7	4,1	6,8	0,0035	V G5	11	1400	21
3	HBV 100 LA 2	2860	10	6,8	0,78	81,5	82	80,1	3,6	3,8	6	0,0062	V 06	15	1060	23
4 *	HBV 100 LB 2	2860	13,4	8,8	0,79	83,1	82,5	80	3,8	4,4	7	0,0073	V 06	15	1000	27
4	HBV 112 M 2	2880	13,3	8,8	0,79	83,3	83,6	82	3	3,8	6,2	0,0081	V 06	15	1000	30
5,5 *	HBV 112 MB 2	2890	18,2	11,6	0,81	84,7	84,9	83,2	3,3	3,7	7,2	0,0104	V G6	25	900	35
7,5 *	HBV 112 MC 2	2870	25	16,5	0,79	83	84,4	83,7	3	3,7	6,4	0,0112	V G6	25	800	37
5,5	HBV 132 S 2	2900	18,1	11,3	0,83	84,7	84,3	82,1	2,6	3,4	6,3	0,0151	V 07	30	900	51
7,5	HBV 132 SB 2	2910	24,6	14,3	0,87	86,9	87,2	85,5	2,9	3,7	7,2	0,0185	V 07	30	850	54
9,2 *	HBV 132 SC 2	2910	30,2	18,7	0,82	87	87,3	85,7	3	3,8	7,7	0,0208	V 07	30	850	56
11 *	HBV 132 MA 2	2920	36	20,5	0,88	87,6	87,5	85,9	3,2	3,9	8,3	0,0242	V G7	50	800	63
15 *	HBV 132 MB 2	2920	49,1	30	0,85	88,7	86,2	84	3,7	4,1	8,3	0,0298	V G7	50	670	74
11	HBV 160 SA 2	2920	36	20,5	0,88	87,6	87,5	85,9	3,2	3,9	8,3	0,0242	V G7	50	800	72
15	HBV 160 SB 2	2920	49,1	30	0,83	88,7	86,2	84	3,9	4,3	8,3	0,0298	V G7	50	670	83

Efficiency value not complying with IE3 class range (IEC 60034-30); nominal power and name plate referred to S3 70% intermittent duty.

* Power or motor power-to-size correspondence not according to standard.

□ Temperature rise class F.

Technical data 400V 50 Hz

2 poles - 3000 min⁻¹
 IP 55
 IC 411
 Insulation class F
 Temperature rise class B

IE3
400V - 50Hz
ErP

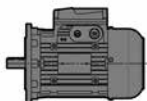

P _N	Motor	n _N	M _N	I _N	cos φ	η			M _S / M _N	M _{max} / M _N	I _S / I _N	J ₀	Brake	M _f	z ₀	kg
						IEC 60034-2-1										
kW		min ⁻¹	N m	A 400 V		100%	75%	50%			kg m ²		N m	starts/h		
0,75	HB3V 80 A 2	2870	2,5	1,7	0,78	80,7	79,9	76,7	3,6	3,8	7,3	0,0019	V 04	7	1500	10
1,1	HB3V 80 B 2	2875	3,7	2,3	0,84	82,7	83,2	81	3,9	3,9	7,7	0,0023	V 04	7	1500	13,5
1,5	HB3V 90 S 2	2890	4,97	2,9	0,88	84,2	84,5	83,3	3,3	3,6	7,9	0,003	V 05	7	1400	18
2,2	HB3V 90 LA 2	2890	7,3	4,4	0,85	85,9	86,2	85,1	3,9	4,4	8,4	0,0034	V G5	11	1800	20
3	HB3V 100 LA 2	2930	9,8	6,2	0,80	87,1	87,2	85,2	4,2	5,1	10,1	0,0074	V 06	15	950	27
4	HB3V 112 M 2	2940	13	7,6	0,87	88,1	88,2	86,7	2,8	4,2	9,8	0,0104	V 06	15	950	36
5,5	HB3V 132 S 2	2960	17,8	10,4	0,85	89,2	88,6	85,6	5,2	6,1	12,7	0,0224	V 07	30	700	61
7,5	HB3V 132 SB 2	2960	24,3	14	0,85	90,1	89,9	87,3	5,7	6,5	13,6	0,0265	V 07	30	700	69,5
9,2 *	HB3V 132 SC 2	2960	29,7	17,3	0,84	90,7	89,9	87,4	5,7	6,3	13,4	0,0293	V 07	30	700	75
11 *	HB3V 132 MA 2	2950	35,7	20	0,87	91,2	90,1	88,4	5,2	4,9	11,6	0,0293	V G7	50	700	75
11	HB3V 160 SA 2	2950	35,7	20	0,87	91,2	90,1	88,4	5,2	4,9	11,6	0,0293	V G7	50	700	84

*) Power or motor power-to-size correspondence not according to standard.

6.6

Technical data 400V 50 Hz

4 poles - 1500 min⁻¹

IP 55

IC 411

Insulation class F

Temperature rise class B

IE2 P_N 0,12 ... 0,55 kW

P_N ≥ 0,75 kW S3 70%

400V - 50Hz

ErP

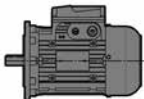

P _N kW	Motor	n _N min ⁻¹	M _N N m	I _N A 400 V	cos φ	η IEC 60034-2-1			M _S / M _N	M _{max} / M _N	I _S / I _N	J ₀ kg m ²	Brake	M _f N m	z ₀ starts/h	kg
						100%	75%	50%								
0,12	HB2V 63 A 4	1370	0,84	0,46	0,63	61,4	58,9	51,9	2,5	2,6	3,1	0,0005	V 02	2,5	5600	4,9
0,18	HB2V 63 B 4	1350	1,28	0,64	0,66	65	64,1	58,4	2,6	2,5	3,3	0,0006	V 02	2,5	6000	5,5
0,25 *	HB2V 63 C 4	1360	1,76	0,83	0,65	68,5	67,8	62,8	2,8	2,7	3,5	0,0007	V 02	2,5	5300	6,3
0,25	HB2V 71 A 4	1400	1,71	0,8	0,71	68,5	66,6	60,7	2,3	2,6	3,8	0,0012	V 03	4	6000	7
0,37	HB2V 71 B 4	1400	2,52	1,1	0,70	73,2	72,2	67,3	2,7	3,2	4,6	0,0014	V 03	4	6700	7,9
0,55 *	HB2V 71 C 4	1400	3,75	1,5	0,70	77,1	75,7	72	3,3	3,5	5,1	0,0018	V 03	4	5600	9,4
0,75*	HBV 71 D 4	1370	5,2	2,15	0,7	72,1	73,3	69,1	2,8	2,9	4	0,0018	V 03	4	5300	9,4
0,55	HB2V 80 A 4	1420	3,69	1,34	0,78	77,1	76	72	2,9	3,1	5,8	0,0034	V 04	7	5300	11
0,75	HBV 80 B 4	1410	5,1	1,9	0,77	74,7	74,2	70,5	2,8	3	5,2	0,0034	V 04	7	5000	11
1,1 *	HBV 80 C 4	1400	7,5	2,8	0,79	75	75,6	72	2,9	3	5,2	0,0042	V 04	7	3750	13
1,1	HBV 90 S 4	1410	7,4	3	0,7	75,2	74,7	70	2,6	2,9	4,4	0,0035	V 05	7	3750	15
1,5	HBV 90 L 4	1410	10,2	3,9	0,71	77,2	79	74,5	3,2	3,6	5,2	0,0044	V 05	7	3550	18
1,85 *	HBV 90 LB 4	1400	12,6	4,5	0,76	78,6	80	77,1	2,9	3,2	5,1	0,0047	V G5	11	3550	19
2,2 *	□ HBV 90 LC 4	1400	15	5,7	0,7	79,7	80,3	77,2	2,8	3,2	4,9	0,0052	V G5	11	2800	21
2,2	HBV 100 LA 4	1420	14,8	5,1	0,78	80	80,8	79,2	2,7	3,2	5,1	0,0081	V 06	15	2120	23
3	HBV 100 LB 4	1425	20,1	6,9	0,76	82,8	83,7	82	2,8	3,2	5,5	0,0098	V 06	15	2360	27
4	HBV 112 M 4	1430	26,7	9,2	0,75	83,4	84,1	82,6	3	3,4	6	0,0144	V G6	25	2000	34
5,5 *	□ HBV 112 MC 4	1420	37	12,3	0,76	84,7	86,1	85,7	3	3,4	6,1	0,0166	V G6	25	1500	37
5,5	HBV 132 S 4	1450	36,2	12,2	0,76	86,3	86,9	85,7	3,2	3,4	6,3	0,0285	V 07	30	1500	53
7,5	HBV 132 M 4	1450	49,4	15,8	0,79	87,1	87,7	86,5	3,4	3,6	7	0,037	V G7	50	1120	62
9,2 *	HBV 132 MB 4	1450	61	19,5	0,77	88	89,4	87,6	3,5	3,8	7,2	0,0426	V G7	50	1030	68
11 *	□ HBV 132 MC 4	1450	72	23	0,78	87,8	88,2	87	3,5	3,8	7,3	0,0482	V G7	50	850	74
11	□ HBV 160 SC 4	1450	72	23	0,78	87,8	88,2	87	3,5	3,8	7,3	0,0482	V G7	50	850	83

Efficiency value not complying with IE3 class range (IEC 60034-30); nominal power and name plate referred to S3 70% intermittent duty.

* Power or motor power-to-size correspondence not according to standard.

□ Temperature rise class F.

Technical data 400V 50 Hz

4 poles - 1500 min⁻¹
 IP 55
 IC 411
 Insulation class F
 Temperature rise class B

IE3
400V - 50Hz
ErP

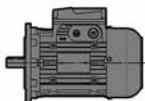

P _N kW	Motor	n _N min ⁻¹	M _N N m	I _N A 400 V	cos φ	η IE3 IEC 60034-2-1			M _S / M _N	M _{max} / M _N	I _S / I _N	J ₀ kg m ²	Brake	M _f N m	z ₀ starts/h	kg
						100%	75%	50%								
0,75	HB3V 80 B 4	1410	5,1	2	0,67	82,5	82,2	80,1	3,2	3,3	5,3	0,0028	V 04	7	4800	14
1,1	HB3V 90 S 4	1420	7,4	2,4	0,80	84,1	84,8	83,6	3	3,5	6,4	0,0052	V 05	7	3150	20,5
1,5	HB3V 90 L 4	1430	10,1	3,3	0,78	85,3	86,1	85	3,1	3,7	6,7	0,0054	V 05	7	3000	21
1,85 ¹⁾	HB3V 90 LB 4	1425	12,4	4,3	0,73	86	85,3	83,4	3,4	3,7	6,4	0,0054	V G5	11	2800	21
2,2	HB3V 100 LA 4	1440	14,6	4,8	0,76	86,7	87,2	85,5	3,5	4,4	7,4	0,011	V 06	15	2200	29
3 *	HB3V 112 MA 4	1450	19,8	6,1	0,80	88,7	88,6	87,3	3,5	4,4	8,8	0,013	V 06	15	2000	36
4	HB3V 112 M 4	1450	26,3	8,5	0,77	88,6	89,2	88	3,7	4,6	9	0,018	V G6	25	1800	39
5,5	HB3V 132 S 4	1470	35,8	12	0,74	89,6	89,5	87,6	4,5	5	9,1	0,041	V 07	30	900	66
7,5	HB3V 132 M 4	1460	49	15,2	0,79	90,4	90,4	89,6	3,9	4,2	8,4	0,048	V G7	50	900	74
9,2 *	HB3V 132 MB 4	1460	60,2	19,2	0,76	91	90,8	90,1	4	4,1	8,5	0,05	V G7	50	800	76,5

*) Power or motor power-to-size correspondence not according to standard.

1) Available only for 50Hz voltages

6.6

Technical data 400V 50 Hz

6 poles - 1000 min⁻¹

IP 55

IC 411

Insulation class F

Temperature rise class B

IE2 P_N 0,12 ... 0,55 kW

P_N ≥ 0,75 kW S3 70%

400V - 50Hz

ErP

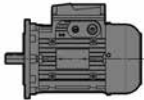

P _N kW	Motor			n _N min ⁻¹	M _N N m	I _N A 400 V	cos φ	η			M _S / M _N	M _{max} / M _N	I _S / I _N	J ₀ kg m ²	Brake		z ₀ starts/h	kg
								IEC 60034-2-1							M _f N m	M _f starts/h		
							100%	75%	50%									
0,09	HBV	63 A	6	900	0,95	0,48	0,57	47,6	43,1	34,4	2,5	2,6	2,3	0,0007	V 02	2,5	7500	5,1
0,12	HB2V	63 B	6	900	1,27	0,55	0,59	52,2	48,3	40,1	2,7	2,8	2,5	0,0008	V 02	2,5	7500	5,5
0,15 *	HB2V	63 C	6	875	1,64	0,62	0,64	55,6	53,2	46	2,5	2,5	2,6	0,0008	V 02	2,5	7500	6,1
0,18	HB2V	71 A	6	900	1,91	0,66	0,67	59,5	57,1	49,8	2,4	2,4	3	0,0014	V 03	4	9500	7,3
0,25	HB2V	71 B	6	900	2,64	0,88	0,67	61,8	59,7	52,9	2,5	2,7	3,3	0,0017	V 03	4	8500	8,1
0,37 *	HB2V	71 C	6	895	3,95	1,2	0,69	67,6	66,1	61	2,6	2,3	3,5	0,0022	V 03	4	8000	9,5
0,37	HB2V	80 A	6	910	3,9	1,2	0,67	67,6	64	57,8	2,7	2,6	3,6	0,0029	V 04	7	6700	9,9
0,55	HB2V	80 B	6	930	5,6	1,6	0,67	73,1	72,2	67,7	3	3	4,5	0,0042	V 04	7	6700	11,5
0,75*	HBV	80 C	6	920	7,8	2,3	0,67	70,1	69,7	64,5	2,5	2,7	3,8	0,0042	V 04	7	5600	13
0,75	HBV	90 S	6	920	7,8	2,2	0,68	72,1	72	67,9	2,4	2,4	3,7	0,0051	V 05	7	5600	15,5
1,1	HBV	90 L	6	915	11,5	3,2	0,68	72,9	72	69,3	2,6	2,8	3,9	0,0067	V G5	11	4750	18,5
1,5 * □	HBV	90 LC	6	910	15,7	4,3	0,68	73,8	72,5	70	2,7	2,9	4,3	0,0077	V G5	11	4500	21
1,5	HBV	100 LA	6	930	15,4	3,9	0,73	75,5	75,4	71,6	2,8	3	4,8	0,0125	V 06	15	2800	24
1,85 *	HBV	100 LB	6	930	19	4,9	0,71	76,6	76,2	72,1	3	3,2	5	0,0147	V 06	15	2650	27
2,2	HBV	112 M	6	940	22,3	5,4	0,75	78,7	79,7	78,1	2,1	2,5	5,0	0,0184	V G6	25	2360	31
3 * □	HBV	112 MC	6	940	30,5	7,2	0,76	79,7	81,2	80,2	2,3	2,7	5,1	0,0225	V G6	25	2240	36
3	HBV	132 S	6	960	29,8	7,8	0,68	82,1	82,3	80,2	2,3	3	5,1	0,0344	V 07	30	2000	50
4	HBV	132 M	6	960	39,8	9,7	0,72	83,2	83,7	81,8	2,5	3	5,7	0,0434	V 07	30	1320	57
5,5	HBV	132 MB	6	960	55	12,9	0,73	84	84,8	83,4	2,6	3	6,3	0,0536	V G7	50	1220	66
7,5 * □	HBV	132 MC	6	950	75	17,6	0,73	84,7	85	83,8	2,4	2,8	5,7	0,0639	V G7	50	950	74
7,5 □	HBV	160 SC	6	950	75	17,6	0,73	84,7	85	83,8	2,4	2,8	5,7	0,0639	V G7	50	950	83

Efficiency value not complying with IE3 class range (IEC 60034-30); nominal power and name plate referred to S3 70% intermittent duty.

*) Power or motor power-to-size correspondence not according to standard.

□ Temperature rise class F.

Technical data 400V 50 Hz
460V 60 Hz

6 poles - 1000 min⁻¹ 50Hz
1200 min⁻¹ 60Hz

IP 55

IC 411

Insulation class F

Temperature rise class B

IE3
400V - 50Hz
460V - 60Hz
ErP

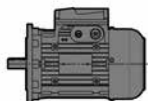

Supply	P_N kW	Motor	n_N min ⁻¹	M_N N m	I_N A	$\cos \varphi$	η IE3 IEC 60034-2-1			M_S / M_N	M_{max} / M_N	I_S / I_N	J_0 kg m ²	Brake M_f N m	z_0 starts/h	
							100%	75%	50%							
Y 400 V 50 Hz 1)	0,75	HB3V 90 S 6	930	7,7	2	0,72	78,9	76	73	2,1	2,9	4,9	0,0067	V 05 7	5600	17,5
	1,1	HB3V 90 L 6	930	11,3	2,8	0,72	81	79	77	2,6	3	5,1	0,0071	V G5 11	4750	22
	1,5	HB3V 100 LA 6	950	15,1	3,5	0,75	82,5	82,4	80,4	2,5	3,4	6,5	0,016	V 06 15	3000	29
	2,2	HB3V 112 M 6	960	21,9	5,1	0,73	84,3	85	83,2	2,3	3,5	6,9	0,024	V G6 25	2800	37
	3	HB3V 132 S 6	970	29,5	6,9	0,72	85,6	88	86,3	2,4	3,8	7,6	0,0485	V 07 30	1400	62
	4	HB3V 132 M 6	970	39,4	9,2	0,71	86,8	88,3	86,3	2,8	4,4	8,4	0,064	V 07 30	1250	74
	5,5	HB3V 132 MB 6	970	54,5	12,2	0,73	88	89,3	88,7	3,2	3,4	7,2	0,065	V G7 50	1100	75
Y 460 V 60 Hz 2)	0,75 *	HB3V 100 LA 6	1160	6,1	1,6	0,71	82,5	84,2	80,9	2,9	4,4	7,9	0,013	V 06 15	3200	29
	1,1 *	HB3V 112 M 6	1160	9,1	2,2	0,73	87,5	88,2	86,8	2,5	3,4	6,3	0,0215	V 06 15	2500	37
	1,5 *	HB3V 112 MB 6	1160	12,3	3,1	0,70	88,5	88,2	86,5	3,0	3,9	6,9	0,0215	V 06 15	2000	37
	2,2 *	HB3V 132 S 6	1170	18	4,3	0,72	89,5	89,9	88,4	2,7	3,6	7,3	0,0358	V 07 30	1400	55
	3 *	HB3V 132 M 6	1170	24,5	5,8	0,72	89,5	90,2	88,7	2,8	3,8	7,6	0,0461	V 07 30	1000	64
4	HB3V 132 MB 6	1170	32,6	7,9	0,70	89,5	91	89,5	3,1	4,1	8,0	0,06	V 07 30	800	75	

1) Motor Size-power combinations available with name plate at 50 Hz only (for other voltage see ch. 6.9 (1)).

2) Motor Size-power combinations available with name plate at 60 Hz only (for other voltage see ch. 6.9 (1)).

*) Power or motor power-to-size correspondence not according to standard.



6.7

Technical data 230.460V 60Hz

4 poles - 1800 min⁻¹
 IP 55
 IC 411
 Insulation class F
 Temperature rise class B
 Service factor **SF 1,15**
 9 terminals

IE2 P_N 0,16 ... 0,75 hp

P_N ≥ 1 hp S3 70%

ErP    ^{US}

230.460V - 60Hz ²⁾

NEMA MG1-12

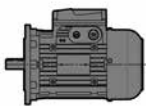

P _N	Motor	n _N	M _N	I _N		PF	NEMA Nom. Eff. MG1-12	NEMA Code	M _S /M _N	M _{max} /M _N	I _S /I _N	J ₀	Brake	M _f	z ₀	
				A 230 V	A 460 V											
0,16 0,12	HB2V 63 A 4	1690	0,68	0,84	0,42	58	65	J	3,1	3,1	3,6	0,0002	V 02	2,5	10000	4,9
0,25 0,18	HB2V 63 B 4	1680	1,02	1,18	0,59	60	69	J	3,3	3,1	3,8	0,0003	V 02	2,5	10000	5,5
0,33 0,25 *	HB2V 63 C 4	1690	1,42	1,5	0,75	59	72,3	J	3,5	3,5	4,2	0,0004	V 02	2,5	8000	6,3
0,33 0,25	HB2V 71 A 4	1720	1,39	1,4	0,7	65	70,9	K	2,8	3,3	4,8	0,0007	V 03	4	8000	7
0,5 0,37	HB2V 71 B 4	1720	2,06	1,9	0,95	65	76	K	3,1	3,8	5,3	0,0009	V 03	4	8000	7,9
0,75 0,55*	HB2V 71 C 4	1720	3,06	2,6	1,3	66	78,8	K	4	4,1	6,3	0,0013	V 03	4	6300	9,4
1 0,75*	HBV 71 D 4	1680	4,23	3,8	1,9	65	77	J	3,4	3,5	4,8	0,0013	V 03	4	5600	8,1
0,75 0,55	HB2V 80 A 4	1740	3	2,4	1,2	74	78,4	L	3,3	3,7	7,2	0,0021	V 04	7	6300	11
1 0,75	HBV 80 B 4	1720	4,14	3,4	1,7	70	78,5	K	3,2	3,5	6,2	0,0021	V 04	7	5600	9,1
1,5 1,1*	HBV 80 C 4	1720	6,2	5	2,5	76	80	J	3,6	3,7	5,7	0,0032	V 04	7	4000	11
1,5 1,1	HBV 90 S 4	1720	6,2	5,4	2,7	68	80	J	3	3,3	5,3	0,0035	V 05	7	3000	15
2 1,5	HBV 90 L 4	1730	8,3	7	3,5	68	81,5	H	3,6	4,2	6	0,0044	V 05	7	2800	18
2,4 1,85 *	HBV 90 LB 4	1710	10,4	8	4	70	84	J	3,6	4	5,6	0,0036	V G5	11	3150	17
3 2,2*	HBV 90 LC 4	1700	12,6	10	5	70	84	J	3,3	3,8	5,4	0,0041	V G5	11	2500	18,5
3 2,2	HBV 100 LA 4	1730	12,3	9,2	4,6	74	85,5	J	3,1	3,7	6,1	0,0081	V 06	15	1700	23
4 3	HBV 100 LB 4	1730	16,4	12,2	6,1	73	85,5	K	3,2	3,7	6,6	0,0098	V 06	15	1900	27
5,4 4	HBV 112 M 4	1740	22,1	16	8	72	85,5	J	3,4	3,9	6,5	0,0144	V G6	25	1600	34
7,5 5,5 *	HBV 112 MC 4	1740	30,7	22,5	11,2	75	87,5	K	3,7	4,2	6,7	0,013	V G6	25	1400	33
7,5 5,5	HBV 132 S 4	1750	30,5	21	10,6	74	87,5	K	3,7	3,9	7,5	0,0285	V 07	30	1180	53
10 7,5	HBV 132 M 4	1750	40,7	27,5	13,7	77	87,5	K	3,9	4,1	7,8	0,037	V G7	50	900	62
12,4 9,2	HBV 132 MB 4	1760	51	35,4	17,7	75	87,5	K	4	4,4	8	0,0376	V G7	50	850	60
15 11	HBV 132 MC 4	1760	61	41	20,5	76,4	89,5	K	4,2	4,7	8	0,0432	V G7	50	710	66
15 11	HBV 160 SC 4	1760	61	41	20,5	76,4	89,5	K	4,2	4,7	8	0,0432	V G7	50	710	75

Nominal power and name plate referred to S3 70% intermittent duty.

1) The name plate contains data expressed in: hp, rpm, PF (power factor) in %.

2) Other supply on request are available, see ch. 6.9 (1).

*) Power or motor power-to-size correspondence not according to standard.

□ Temperature rise class F.

Technical data 230.460V 60Hz

6 poles - 1200 min⁻¹

IP 55

IC 411

Insulation class F

Temperature rise class B

Service factor **SF 1,15**

9 terminals

IE2 P_N 0,16 ... 0,75 hp

P_N ≥ 1 hp S3 70%

ErP  

230.460V - 60Hz²⁾

NEMA MG1-12

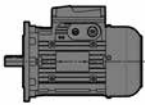

P _N	Motor	n _N	M _N	I _N		PF	NEMA Nom. Eff. MG1-12	NEMA Code	M _S /M _N	M _{max} /M _N	I _S /I _N	J ₀	Brake	M _f	z ₀	
				A 230 V	A 460 V											
1) hp kW		1) RPM	N m			%	%					kg m ²		N m	starts/h	
0,12 0,09	HBV 63 A 6	1120	0,76	0,88	0,44	52	52,5	J	2,9	3	2,7	0,0004	V 02	2,5	10600	4,1
0,16 0,12	HB2V 63 B 6	1120	1,02	1,04	0,52	53	55,8	J	3,1	3,2	2,9	0,0005	V 02	2,5	10000	5,5
0,2 0,15 *	HB2V 63 C 6	1100	1,3	1,2	0,6	56	58	J	3,1	3,2	3	0,0005	V 02	2,5	9500	6,1
0,25 0,18	HB2V 71 A 6	1120	1,53	1,22	0,61	60	62,6	H	3	3,1	3,6	0,0009	V 03	4	10000	7,3
0,33 0,25	HB2V 71 B 6	1120	2,1	1,62	0,81	60	64,9	J	3,1	3,1	3,9	0,0012	V 03	4	9000	8,1
0,5 0,37*	HB2V 71 C 6	1120	3,16	2,2	1,1	63	70,9	J	3,2	3,3	4,5	0,0017	V 03	4	8000	9,5
0,5 0,37*	HB2V 80 A 6	1130	3,12	2,2	1,1	61	68,4	J	3,3	3,5	4,3	0,0019	V 04	7	7500	9,9
0,75 0,55	HB2V 80 B 6	1140	4,6	3	1,5	62	75,7	K	3,6	3,7	5,3	0,0032	V 04	7	7100	13
1 0,75*	HBV 80 C 6	1130	6,3	4	2	62	75,5	J	2,9	3,1	4,6	0,0032	V 04	7	5600	11
1 0,75	HBV 90 S 6	1130	6,3	3,8	1,9	66	75,5	H	2,8	3	4,5	0,0051	V 05	7	4500	15,5
1,5 1,1	HBV 90 L 6	1130	9,4	5,6	2,8	67	75,5	H	3	3,2	4,7	0,0056	V G5	11	4250	17
2 1,5*	□ HBV 90 LC 6	1120	12,7	7,6	3,8	64	77	J	3,1	3,3	5,2	0,0066	V G5	11	4000	18,5
2 1,5	HBV 100 LA 6	1140	12,5	7	3,5	68	80	K	3,2	3,4	5,8	0,0125	V 06	15	2240	24
2,4 1,85*	HBV 100 LB 6	1140	15,6	8,6	4,3	68	80	K	3,4	3,6	6	0,0117	V 06	15	2500	24
3 2,2	HBV 112 M 6	1150	18,6	9,4	4,7	72	82,5	J	2,4	2,9	6	0,0148	V G6	25	2240	27
4 3*	□ HBV 112 MC 6	1150	24,7	12,4	6,2	73	84	J	2,6	3,1	6,1	0,0189	V G6	25	2000	32
4 3	HBV 132 S 6	1160	24,5	13,8	6,8	64	85,5	K	2,6	3,4	6,1	0,0344	V 07	30	1600	50
5,4 4	HBV 132 M 6	1160	33,1	17,2	8,6	70	85,5	K	2,9	3,4	6,9	0,0434	V 07	30	1060	57
7,5 5,5	HBV 132 MB 6	1160	46	23	11,4	72	86,5	L	3	3,4	7,5	0,0486	V G7	50	1000	58
10 7,5	□ HBV 132 MC 6	1150	62	31	15,5	70	86,5	K	2,7	3,2	6,9	0,0589	V G7	50	800	66
10 7,5	□ HBV 160 SC 6	1760	62	31	15,5	70	86,5	K	2,7	3,2	6,9	0,0589	V G7	50	800	75

Nominal power and name plate referred to S3 70% intermittent duty.

1) The name plate contains data expressed in: hp, rpm, PF (power factor) in %.

2) Other supply on request are available, see ch. 6.9 (1).

*) Power or motor power-to-size correspondence not according to standard.

□ Temperature rise class F.

6.8

Technical data 380V 60Hz

4 poles - 1700 min⁻¹

IP 55

IC 411

Insulation class F

Temperature rise class B

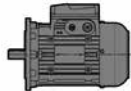

U.T.C. 1371

P _N	Motor	n _N	M _N	I _N	cos φ	η			M _S / M _N	M _{max} / M _N	I _S / I _N	J ₀	Brake	Mf	z ₀	kg
						IEC 60034-2-1										
kW		min ⁻¹	N m	A 380 V		100%	75%	50%				kg m ²		N m	avv./h	
0,75	HB3V 80B 4	1730	4,1	2,2	0,62	83,5	83,8	81,1	3,7	3,8	6,1	0,0028	V04	7	3840	14
1,1	HB3V 90S 4	1735	6,1	2,6	0,77	86,5	85,5	83,3	3,3	3,7	7,5	0,0052	V05	7	2520	20,5
1,5	HB3V 90L 4	1740	8,3	3,7	0,75	86,5	84,0	82,5	3,4	4,4	7,9	0,0054	V05	7	2400	21
2,2	HB3V 100LA 4	1750	12,0	5,2	0,73	89,5	87,7	85,3	4,1	4,6	8,2	0,011	V06	15	1760	29
3 *	HB3V 112MA 4	1760	16,3	6,5	0,77	89,5	89,5	87,5	4,1	4,9	9,2	0,013	V06	15	1600	36
4	HB3V 112M 4	1760	21,8	9,0	0,75	89,5	90,2	88,7	4,0	5,5	10,3	0,018	VG6	25	1440	39
5,5	HB3V 132S 4	1770	29,7	12,8	0,71	91,7	90,2	88,2	4,6	5,2	9,8	0,041	V07	30	720	66
7,5	HB3V 132M 4	1765	40,5	16,0	0,77	91,7	90,9	89,4	4,7	4,9	10,0	0,048	VG7	50	720	74
9,2 *	HB3V 132MB 4	1765	49,8	20,5	0,73	92,4	91,8	90,6	4,3	4,4	8,7	0,05	VG7	50	640	76,5

* Power or motor power-to-size correspondence not according to standard.

Technical data 380V 60Hz

6 poles - 1100 min⁻¹

IP 55

IC 411

Insulation class F

Temperature rise class B

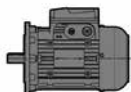

UT.C. 1371

P _N kW	Motor		n _N min ⁻¹	M _N N m	I _N A 380 V	cos φ	η IEC 60034-2-1			M _S / M _N	M _{max} / M _N	I _S / I _N	J ₀ kg m ²	Brake	Mf N m	z ₀ avv./h	kg
							100%	75%	50%								
0,75 *	HB3V	100LA 6	1160	6,1	1,9	0,71	82,5	84,2	80,9	2,9	4,4	7,9	0,013	V06	15	3200	29
1,1 *	HB3V	112M 6	1160	9,1	2,6	0,73	87,5	88,2	86,8	2,5	3,4	6,3	0,0215	V06	15	2500	37
1,5 *	HB3V	112MB 6	1160	12,3	3,7	0,70	88,5	88,2	86,5	3,0	3,9	6,9	0,0215	V06	15	2000	37
2,2 *	HB3V	132S 6	1170	18,0	5,2	0,72	89,5	89,9	88,4	2,7	3,6	7,3	0,0358	V07	30	1400	55
3 *	HB3V	132M 6	1170	24,5	7,0	0,72	89,5	90,2	88,7	2,8	3,8	7,6	0,0461	V07	30	1000	64
4	HB3V	132MB 6	1170	32,6	9,5	0,70	89,5	91	89,5	3,1	4,1	8,0	0,06	V07	30	800	75

* Power or motor power-to-size correspondence not according to standard.

6.9

Motor dimensions

Mounting position
IM B5, IM B5R, IM B6...

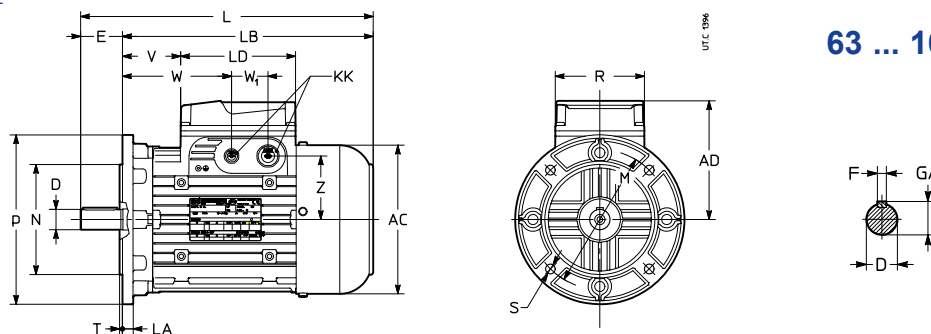

63 ... 160S

Motor size	AC	AD	L	LB	LD	KK	R	V	W	W ₁	Z	Shaft end				Flange														
												D	1)	E	F	GA	M	N	P	LA	S	T								
	∅					2)						∅		h9		∅	∅	∅	∅											
63	B5R	123	95	242	222	103	4×M16	86	46	86	36	45	9 j6 M3	20	3	10,2	100	80	j6	120	8	7	3							
	B5A			245																										
	B5			228	205										29	69			11 ³⁾ j6 M4	23 ³⁾	4	12,5	130	110	j6	160		9	3,5	
71	B5B	138	112	266	243		2×M16 + 2×M20		66	106		62	11 j6 M4	23	4	12,5	100	80	j6	120	8	7	3							
	B5R																													
	B5A			273															14 j6 M5	30	5	16	115	95	j6	140	10	9		
	B5			254	224										47	87			11 ³⁾ j6 M4	23 ³⁾	4	12,5	130	110	j6	160			3,5	
	BX2			247															14 ³⁾ j6 M5	30 ³⁾	5	16								
	BX5			254																			165	130	j6	200	12	11		
80	B5B	156	121	293	263				80	120		71	14 j6 M5	30	5	16	115	95	j6	140	10	9	3							
	B5R																													
	B5A			303															19 j6 M6	40	6	21,5	130	110	j6	160			3,5	
	B5			282	242										59	99			14 ³⁾ j6 M5	30 ³⁾	5	16	165	130	j6	200	12	11		
90 S ⁴⁾	B5S	176	141	317	287	136	2×M16 + 2×M25	106	60	120	43	75	14 j6 M5	30	5	16	130	110	j6	160	10	9								
	B5B			327																										
	B5R			306	266														19 j6 M6	40	6	21,5	165	130	j6	200	12	11		
	B5			316															24 j6 M8	50	8	27								
90 L	B5S			347					90	150			14 j6 M5	30	5	16	130	110	j6	160	10	9								
	B5B			357																										
	B5R			336	296											69	129			19 j6 M6	40	6	21,5	165	130	j6	200	12	11	
	B5			346															24 j6 M8	50	8	27								
100	B5C	194	151	387	347				109	169		86	19 j6 M6	40	6	21,5	130	110	j6	160	10	9								
	B5S																													
	B5R			397															24 j6 M8	50	8	27	165	130	j6	200	12	11		
	B5A			407															28 j6 M10	60	8	31								
112	B5	218	163	409	369				82	142		98	19 j6 M6	40	6	21,5	165	130	j6	200	12	11	3,5							
	B5R			419																										
	B5A			429															28 j6 M10	60	8	31	215	180	j6	250	14	14	4	
	B5			403	343										100	160							265	230	j6	300				
132 S, M ⁵⁾	B5S	257	194	484	434	190	2×M16 + 2×M32	148	113	201	55	109	24 j6 M8	50	8	27	165	130	j6	200	12	11	3,5							
	B5B			494																										
	B5R																		28 j6 M10	60	8	31	215	180	j6	250	14	14	4	
	B5A			514															38 k6 M12	80	10	41								
132 MA ⁶⁾ ... MCB5S	B5			479	399				78	166																				
	B5B			544	494																									
	B5R			554															24 j6 M8	50	8	27	165	130	j6	200	12	11	3,5	
	B5A			574															28 j6 M10	60	8	31	215	180	j6	250	14	14	4	
160 S	B5			539	459				138	226			38 k6 M12	80	10	41	265	230	j6	300										
				588	478																									
									157	245			42K6 M16	110	12	45	300	250	h6	350	15	18	5							

1) Tapped butt-end hole.

2) Rearranged cable entry knockout openings on both sides (two openings on each side, cable gland and threaded plug not supplied).

3) Shaft end not according to standard.

4) For motors **HB3V 90S 2** and **HB3V 90 S4** the dimensions are the ones of sizes 90L.

5) For motors **HB3V 132SB 2**, **HB3V 132 SC2**, **HB3V 132S 4**, **HB3V 132M 4** and **HB3V 132M 6** the dimensions are the ones of sizes 132 MA ... MC.

6) For motor **HBV 132MA 2** dimensions are the ones of size 132S, M.

Mounting position
IM B14,
IM B14R

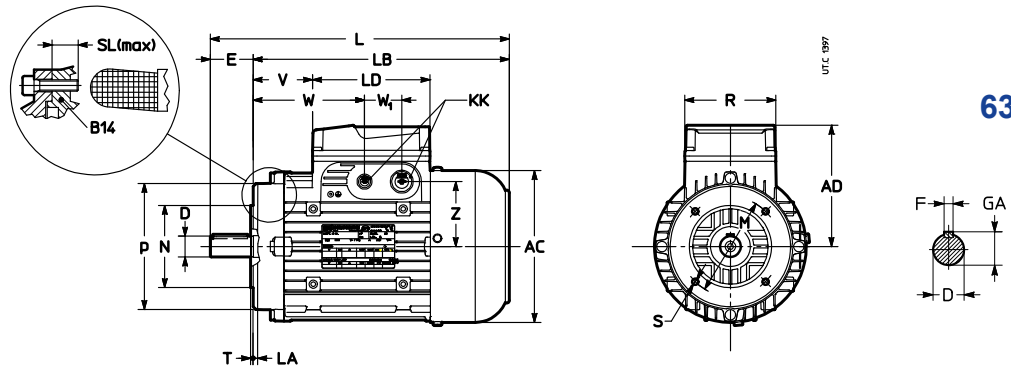

63 ... 132

Motor size	AC	AD	L	LB	LD	KK	R	V	W	W ₁	Z	Shaft end				Flange								
												D	1) E	F	GA	M	N	P	LA	S	SL	T		
	∅					2)						∅	h9	∅	∅	∅	∅	∅	max					
63	B14	123	95	228	205	103	4×M16	86	29	69	36	45	11 j6 M4	23	4	12,5	75	60 j6	90	8	M5	10	2,5	
71	B14R B14	138	112	247	224	103	2×M16 + 2×M20	86	47	87	36	62	14 j6 M5	30	5	16	85	70 j6	105	8	M6	10	2,5	
80	B14R B14	156	121	272	242				59	99		71	19 j6 M6	40	6	21,5	100	80 j6	120	8	M6			3
90 S⁴⁾	B14	176	141	316	266				136	2×M16 + 2×M25		106	39	99	43	75	24 j6 M8	50	8	27	115			95 j6
90 L	B14			346	296				69	129			86	28 j6 M10	60	8	31	130	110 j6	160	10	M8	13	3,5
100	B14	194	151	380	320				82	142														
112	B14	218	163	403	343				100	160		98												
132 S, M⁵⁾	B14	257	194	479	399	190	2×M16 + 2×M32	148	78	166	55	109	38 k6 M12	80	10	41	165	130 j6	200	8	M10	18		
132 MA⁶⁾ ... MC B14				539	459				138	226														

1) Tapped butt-end hole.

2) Prearranged cable entry knockout openings on both sides (two openings on each side, cable gland and threaded plug not supplied).

4) For motors **HB3V 90S 2** and **HB3V 90 S4** the dimensions are the ones of sizes 90L.

5) For motors **HB3V 132SB 2**, **HB3V 132 SC2**, **HB3V 132S 4**, **HB3V 132M 4** and **HB3V 132M 6** the dimensions are the ones of sizes 132 MA ... MC.

6) For motor **HBV 132MA 2** dimensions are the ones of size 132S, M.

Mounting position
IM B3

63 ... 160S

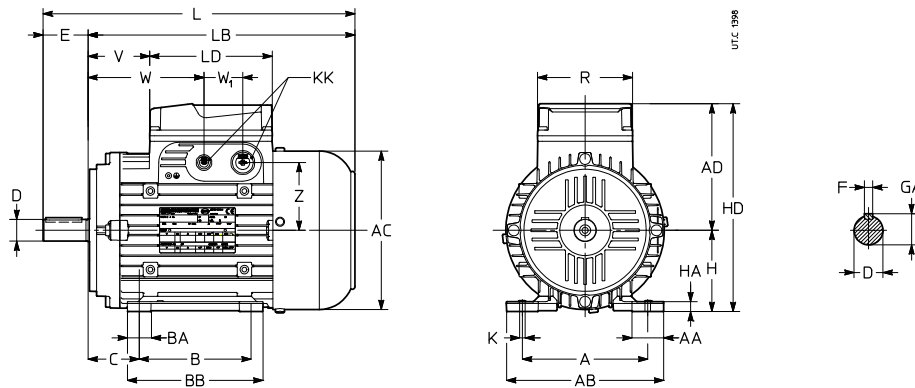

Motor size	AC	AD	L	LB	LD	KK	R	V	W	W ₁	Z	D	Shaft end				Feet																					
													E	F	GA	A	AB	B	C	BB	BA	AA	K	HA	H ⁴⁾	HD												
	∅					2)						∅	1)	h9																								
63	B3	123	95	228	205	103	4×M16	86	29	69	36	45	11 j6 M4	23	4	12,5	100	120	80	40	100	21	27	7	9	63	158											
71	B3	138	112	254	224		2×M16 + 2×M20	—	47	87		62	14 j6 M5	30	5	16	112	138	90	45	110	22	28		10	71	183											
80	B3	156	121	282	242				59	99		71	19 j6 M6	40	6	21,5	125	152	100	50	125	26		9		80	201											
90 S⁵⁾	B3	176	141	316	266	136	2×M16 + 2×M25	106	39		43	75	24 j6 M8	50	8	27	140	174		56			35		11	90	230											
90 L	B3			346	296				69	129									125		150						251											
100	B3	194	151	380	320				82	142		86	28 j6 M10	60	8	31	160	196	140	63	185	40	37	12	12	100	275											
112	B3	218	163	403	343				100	160		98					190	226		70			50		15	112	264											
132 S, M⁶⁾	B3	257	194	479	399	190	2×M16 + 2×M32	148	78	166	55	109	38 k6 M12	80	10	41	216	257	140 ³⁾	89	210	42	52	14	17	132	326											
132 MA⁷⁾... MC	B3			539	459				138	226									178 ³⁾																			
160 S	B3			588	478				157	245		42	k6 M16	110	12	45	254	294	210	108	246	45			20	160	354											

- 1) Tapped butt-end hole.
- 2) Preranged cable entry knockout openings on both sides (two openings on each side, cable gland and plugs not supplied).
- 3) Foot of 132S also has a centre distance of 178 mm and the one of size 132MA ... MC has also a centre distance of 140mm.
- 4) Tolerance ± 0.5 mm.
- 5) For motors **HB3V 90S 2** and **HB3V 90 S4** dimensions are the ones as sizes 90L.
- 6) For motors **HB3V 132SB 2**, **HB3V 132 SC2**, **HB3V 132S 4**, **HB3V 132M 4** e **HB3V 132M 6** dimensions are the ones as sizes 132 MA ... MC.
- 7) For motor **HBV132 MA 2** dimensions are the same ones of size 132S.

Non-standard designs and accessories

Ref.	Description	Non-standard design code
(1)	Non-standard motor supply	–
(3)	Insulation class H	,H
(7)	Design for low temperatures (-30 °C)	,BT
(8)	Condensate drain holes	,CD
(9)	Additional winding impregnation	,SP
(13)	Anti-condensation heater	,S
(14)	Terminal box on one side (IM B3 and derivatives 90 ... 160S)	,P...
(19)	Thermistor type thermal probes (PTC)	,T15
(20)	Bi-metal type thermal probes	,B15
(21)	Drip-proof cover	,PP
(26)	Separate d.c. brake supply	see 6.8(26)
(28)	Noise-reducing capacitor (EMC directive)	,EC
(42)	Motor certified to UL	,UL

(1) Non-standard motor supply

The first two columns show the possible types of supply.

Supply values of brake rectifier is **co-ordinated** with motor winding voltage as stated in the table

Motor wound and stated for		Rectifier DIRECTLY connected to motor terminal box (center phase start)				Motor type		
V	Hz	Brake size	Brake size	Rectifier supply [V]	Coil voltage [Vdc]	HBV	HB2V	HB3V
		02 ... 07	G5 ... G7	V ~ ± 5%	V dc ± 5%			
		Rectifier						
Δ220 Y380	50	RN1	RR1	220	103	○	●	●
Δ230 Y400	50	RN1	RR1	230	103	●	●	●
Δ265 Y460	60	RN1	RR1	265	119	○	○	○
Δ277 Y480	60	RN1	RR1	277	119	○	○	○
Δ240 Y415	50	RN1	RR1	240	103	○	●	●
YY230 Y460 ³⁾	60	RN1	RR8	460 ⁴⁾	206	○	○	○
Δ400	50	RN1	RR1	400	178	○	○	○
Δ480	60	RN1	RR8	480	206	○	○	○
Δ255 Y440	60	RN1	RR1	255	119	○	○	○
Δ415	50	RN1	RR1	415	178	○	○	○
Δ440	60	RN1	RR8	440	206	○	○	○
Δ460	60	RN1	RR8	460	206	○	○	○
Δ220 Y380	60	RN1	RR1	220	103	○	○	○
Δ380	60	RN1	RR1	380	178	○	○	○
Δ290 Y500	50	RN1	RR1	290	130	○	○	○
Δ346 Y600	60	RN1	RR1	346	156	○	○	○

● standard ○ on request

3) For motor supply 230/60 YY consult us.

4) Rectifier connected directly to motor terminal block between 2 phases.

For different voltage values consult us.

Designation: by following instructions at ch. 6.2, state **voltage** and **frequency** (in the first table columns).

(3) Insulation class H

Insulation materials in class H with permissible temperature rise in class H.

Non-standard design code for the **designation: ,H**

(7) Design for low temperatures (-30 °C)

Standard motors can operate for possible ambient temperature down to -15 °C.

For ambient temperature down to -30 °C: special bearings, (in addition of cable glands and metal plugs, if available).

If there are dangers of condensate, it is advisable to require also the design «Design for damp and corrosive environment» (47), and optionally «Condensate drain holes» (8) and/or «Anti-condensation heater» (13).

May there be dangers of ice on friction surface consult us.







Non-standard design code for the **designation: ,BT**

(8) Condensate drain holes

It is advisable for motors operating in particularly damp environments and/or with wide variation in the temperature and/or at low temperature. In motor designation state in «MOUNTING POSITION» the designation of the real application mounting position, determining the hole position.

Motors are supplied with closed holes.

Non-standard design code for the **designation: ,CD.**

Mounting position						
IM						
B3	IM 1001	IM 1011	IM 1031	IM 1051	IM 1061	IM 1071
B5	IM 3001	IM 3011	IM 3031	IM 3051	IM 3061	IM 3071
B14	IM 3601	IM 3611	IM 3631	IM 3651	IM 3661	IM 3671
B3-B5	IM 2001	IM 2011	IM 2031	IM 2051	IM 2061	IM 2071
B3-B14	IM 2101	IM 2111	IM 2131	IM 2161	IM 2161	IM 2171

(9) Additional windings impregnation

If consists of a second impregnation cycle after stator winding assembly.

Useful where it is necessary to have an additional protection (of the windings) against electrical stress (voltage peaks due to rapid commutations or to «low quality» inverters with high voltage gradients) or mechanical agents (mechanical or electromagnetic vibrations: e.g. from inverter). See also ch. 2.9 «Voltage peaks (U_{max}), voltage gradients (dU/dt), cable length».

Non-standard design code for the **designation: ,SP**

(13) Anti-condensation heater

It is advisable for motors operating in particularly damp environments and/or with wide variation in the temperature and/or at low temperature; single-phase supply 230 V a.c. $\pm 10\%$ 50 or 60 Hz (other voltage on request); power absorbed: 15 W for sizes 63 and 71, 25 W for sizes 80 ... 100, 50 W for sizes 112 ... 160S. Heater must not be connected during the running.

Non-standard design code for the **designation: ,S**

(14) Terminal box on one side for IM B3 and derivatives (sizes 90 ... 160S)

Terminal box in position P1 or P2.

Non-standard design code for the **designation:**

,P... (additional code **1** or **2** according to scheme beside).

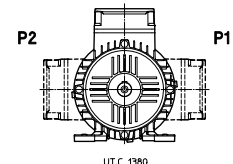

(19) Thermistor type thermal probes (PTC)

Three thermistors wired in series (to DIN 44081/44082), inserted in the windings, for connection to a suitable contact breaker device. A sharp variation in resistance occurs when (delay $10 \div 30$ s) the temperature of the windings reaches the setting temperature of **150 °C (T15)**.

With design (3) «Insulation class H» if required, **thermistors** with setting temperature of 170 °C (**T17**) are supplied.

Terminals connected to a loose or fixed terminal block inside the terminal box.

Non-standard design code for the **designation: ,T15**

(20) Bi-metal type thermal probes

Three bi-metal probes wired in series with usually closed contact inserted in the windings. Nominal current 1,6 A, nominal voltage 250 V a.c.. The contact opens when (delay $20 \div 60$ s) the temperature of the windings reaches the setting temperature of **150 °C (B15)**.

With design (3) «Insulation class H» if required, **bi-metal probes** with setting temperature of 170 °C (**B17**) are supplied.

Terminals connected to a loose or fixed terminal block inside the terminal box.

Non-standard design code for the **designation: ,B15**

(21) Drip-proof cover

Necessary design for outdoor applications or when water sprays are present, in mounting position with downwards vertical shaft (IM V5, IM V1, IM V18).

LB dimension (see. ch. 6.8) increases by $\Delta LB = 26$.

Non-standard design code for the **designation**: **,PP**

(26) Separate d.c. brake supply

Motors are standard supplied according to ch. 6.9 (1). Separate brake supply is necessary in various applications (e.g.: motors supplied by inverter). On request, the following rectifier input supply voltages are available.

For the **designation** use the non-standard design codes stated in the table.

Brake size	Rectifier supply	Name plate data		
		Rectifier	Nominal brake coil voltage V dc \pm 5%	Code
	V~			
02 ... 07	24 V c.c. ⁽¹⁾⁷⁾	-	24	,F17
	110	RD1 ⁽⁴⁾	103	,F15
	220 ... 240	RN1	103	,F1C
	255 ... 277	RN1	119	,F4
	290	RN1	130	,F7
	330 ... 346	RN1	156	,F21
	380 ... 415	RN1	178	,F10
	440 ... 480	RN1	206	,F12B
500	RN1	224	,F14	
G5 ... G7	110	RR5 ⁽³⁾	51	,F15
	220 ... 240	RR1	103	,F1C
	255 ... 277	RR1	119	,F4
	290	RR1	130	,F7
	330 ... 346	RR1	156	,F21
	380 ... 415	RR1 ⁽⁶⁾	178	,F10
	440 ... 480	RR8 ⁽³⁾	206	,F12B
	500	RR8 ⁽³⁾	224	,F14

1) Rectifier is not supplied.

3) Single half-wave rectifiers (for wiring schemes see point 6.5).

4) Double half-waves rectifier RD1: output d.c. voltage \approx 0,9 input a.c. supply voltage (connections equal to RN1, see point 6.5).

6) In case of disconnection on a.c. and d.c. side and high number of starts use a RR8 rectifier.

7) For higher sizes and G5 ... G7 consult us. It may be necessary to reduce M_f value.

(28) Noise-reducing capacitor (EMC dir.)

Rectifier-brake coil group can comply with standard EN 50081-1 (emission levels for civil environments) and EN 50082-2 (immunity for industrial environments) through a parallel connection of rectifier a.c. supply with a noise-reducing capacitor or filter (consult us for relevant features).

Non-standard design code for the **designation**: **,EC**

(42) Motor certified to UL

Motor sizes 63 ... 160S certified (\leq 750 V, 50/60 Hz) both to UL1004-1 and CAN/CSA 22.2 No.100-14, for USA and Canada markets respectively, and electrically complying with NEMA Standard Publication MG 1-12 2009.

The main variations of this product are:

- approved UL class F insulation winding system;
- approved UL terminal block terminal assignment according to NEMA;
- certified and marked cables;
- verification and adjustment of air distances toward ground and between live parts;
- name plate with logo , showing only the data relating to the supply required in the order.
- motor with $P_N \geq 1$ hp are available with intermittent duty cycle S3 70%.

As standard, in case of motor supply 230 YY 460 Y V, 60 Hz.

Non-standard design code for the **designation**: **,UL**.

Miscellaneous

- Asynchronous three-phase two-speed motors.
- Asynchronous single-phase motors with running capacitor always switched on, running + starting and electronic disjuncter, balanced winding.
- Special paints or completely unpainted motor.
- Motor balancing according to reduced vibration degree (R) to CEI EN 60034-16.
- Motors with integral feet and flange (IM B35, IM B34 and relevant vertical mounting positions).
- Power connector.
- Sensorized drive end bearing (32, 48 or 64 pulses per rotation) for the measurement of angle and/or rotation speed (sizes 63 ... 100); for specifications and wiring schemes consult us.
- Pt 100 temperature probe.
- Axial independent cooling fan.
- Axial independent cooling fan and encoder.
- Encoder
- Encoder for high temperatures.
- Designs with supply cable.
- Design for oil seal (e.g. coupled with mechanical variator).

6.11

Name plate

MOT. (1)~ (9)	(2) (3) (4) (5)	IP (6)	AMB. (7)	IC (8)	
(14)	(10)	kg (11)	I.CL. (12)	S (13)	
(15)	Frano Brake (30)	Nm (31)	V~/Hz (32)	A (33)	#/## (34) V= (35)
DE/NDE (16)					
(17)					
(19) V (19)	% (21)	Hz (22)	% (23)	A (24)	kW (25) min ⁻¹ (26) cos φ (27)
(20)	(21)	(22)	(23)	(24)	(25) (26) (27)
(28)					
(29)					

UTC 2291

MOT.(1)~N. (9)	(10)	IP (6)	AMB.(7)	IC (8)	
(2) (3) (4) (5)		kg (11)	I.CL.(12)S (13)		
Frano Brake (30)	Nm (31)	V~/Hz (32)	A (33)	##/## (34)	V= (35)
(14)					
(15)					
(10)					
NEMA MG1-12 SF (36) DESIGN (29) CODE (29)					
(19) V (19)	Hz (22)	A (24)	HP (25)	RPM (26)	PF (27) NOM. EFF (28)
(20)	(22)	(24)	(25)	(26)	(27) (28)

UTC 1619B

NEMA YY230 Y460 V, 60Hz

- (1) Number of phases
- (2) Motor type
- (3) Size
- (4) Number of poles
- (5) Designation of mounting position
- (6) Protection IP ...
- (7) Maximum ambient temperature
- (8) Code IC
- (9) Production number
- (10) Two months and year of manufacturing end serial number
- (11) Motor mass
- (12) Insulation class I.CL....
- (13) Duty cycle S...
- (14) Motor code
- (15) Customer code¹⁾
- (16) Bearings
- (17) Note 1
- (18) Note 2
- (19) Connection of the phases
- (20) Nominal voltage
- (21) Voltage tolerance
- (22) Nominal frequency
- (23) Frequency tolerance
- (24) Nominal current
- (25) Nominal power
- (26) Nominal speed
- (27) Nominal power factor
- (28) Nominal efficiency IEC 60034-2-1
- (29) Design - code
- (30) Brake size
- (31) Brake braking torque
- (32) Rectifier supply
- (33) Current absorbed by brake
- (34) Rectifier designation
- (35) D.c. nominal voltage of brake supply
- (36) Service factor

1) On request.

MOT. 3 ~ HB3V 90L 4 B5		IP 55	AMB. 40°C	IC 411	
2381026 03/21 7623235		kg 21	I.CL. F	S 1	
R000245982	Frano Brake V05	Nm 7	V~/Hz 220-240/50	A 0.24	##/## RN1 V= 103
DE/NDE h g					
(17)					
Δ V Y	%	Hz	%	A	kW min ⁻¹ cos φ
220/380		50		5.9/3.4	1.5 1415 0.81
230/400		50		5.7/3.3	1.5 1430 0.78
240/415		50		5.7/3.3	1.5 1430 0.76
50Hz: IE3 85.3(100%) 86.1(75%) 85(50%)					

UTC 2373

MOT.3~N.1579655 06/16		IP 55	AMB.40°C	IC411	
HBV 112M 4 B5		kg 34	I.CL.F S3 70%		
Frano Brake VG6	Nm 25	V~/Hz 230/60	A 0.34	##/## RR1	V= 103
R000099775 651777					
NEMA MG1-12 SF 1.15 INT. DUTY DESIGN C CODE K					
Δ V Y	Hz	A	HP	RPM	PF NOM.EFF
230/460	60	14.2/7.1	5.4	1740	81% 87.5%

UTC 1622B

Standard voltage/frequency on name plate

Motors required with supply voltage $\Delta 230$ Y400V 50Hz are supplied as standard with the following voltage/frequency values stated on motor nameplate, see following table:

Motor Type	Voltage/Frequency on nameplate	Voltage/Frequency on nameplate with design ,UL (42)
HBV	230.400 50	230.400 50
HB2V	220.380 50 230.400 50 240.415 50	230.400 50
HB3V 2, 4 Poles	220.380 50 230.400 50 240.415 50	230.400 50
HB3V 6 Poles	220.380 50 230.400 50 240.415 50	230.400 50

Other voltage types are available on request as already explained in the design (1) "Non-standard motor supply", in the specific case only the required supply will be stated on nameplate.

Asynchronous three-phase motor HE

Section Contents

7.1	General specifications	178
7.2	Designation	179
7.3	Specifications	179
7.4	Radial and axial loads on shaft end	182
7.5	Technical data 400V 50Hz	184
7.6	Motor dimensions	186
7.7	Non-standard designs and accessories	188
7.8	Name plate	195

7.1

General specifications

160 ... 315

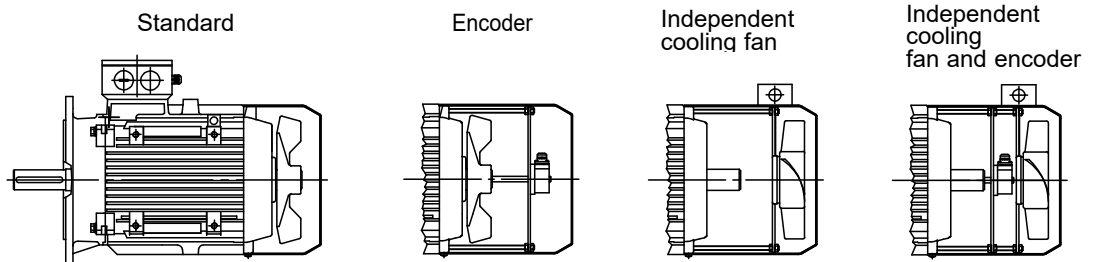

Range of asynchronous three-phase motors sizes 160... 315.

Class F insulation, temperature rise class B for all motors at standard power, B or F for remaining motors

Mounting positions IM B3, B5 and derivatives.

IP 55 protection

«Supported» tightening attachments of endshields and flanges

Metallic terminal box

Suitable for operation with inverter

The following designs are **standard** for the whole range:

- **Cable glands already assembled** oriented on nameplate side
- **Axial fastening on drive end**
- **Thermistor type thermal probes (PTC) 150 °C**
- **Suitable for inverter operation**
- **5 voltage values stated on nameplate**
- **Standard condensate drain hole from sizes 180 ... 315**
(For B5 motor n. 1 hole on flange and n. 2 holes on housing respectively on drive end and non drive end.
For B3 and B5R motor n. 2 holes on housing respectively on drive end and non drive end)
- **suitable for mounting position B3, B5**
- **Terminal box connection already Δ-prearranged connection**
- **NEMA MG 1-12 references stated on nameplate**

Designation

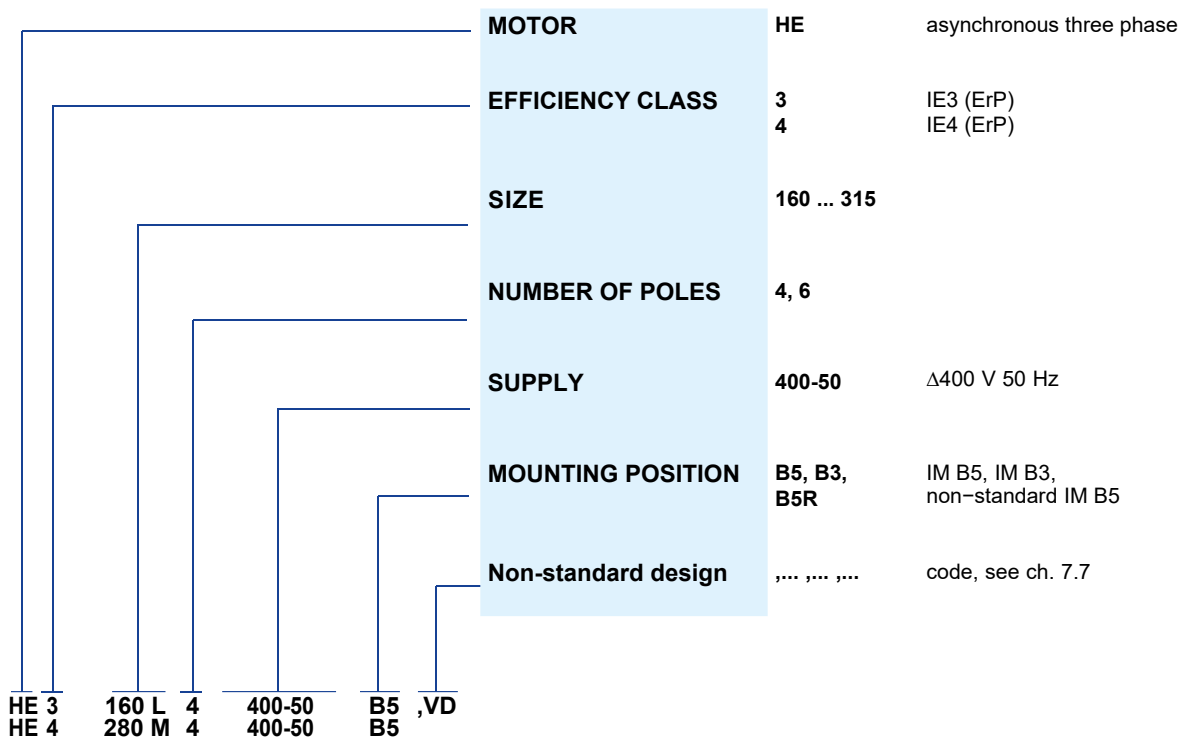

7.3

Specifications

Standardized asynchronous three-phase electric motor with cage rotor, totally enclosed, externally ventilated (cooling system IC 411), single-speed according to following table:

Number of poles	Winding	Motor size	Standard supply		insulation	Class temperature rise
			50 Hz	60 Hz		
4, 6	three-phase Δ	160 ... 315	Δ 380 V	F	B ¹⁾	
			Δ 400 V			
			Δ 415 V			
			Δ 460 V			
			Δ 480 V			

1) Excluded specific motors (identified by □ at ch. 7.5 ... 7.7) whose temperature rise class is F.

Rated power delivered on continuous duty (S1) at standard voltage and frequency; ambient temperature -15 ÷ 40 °C, altitudes lower than 1000 m.

IP 55 protection

Mounting positions IM B5, IM B3 motors can also operate in the relevant mounting positions with vertical shaft, which are respectively (see following table): IM V1 and IM V3 the name plate shows the designation of mounting position with horizontal shaft

Mounting positions with flange

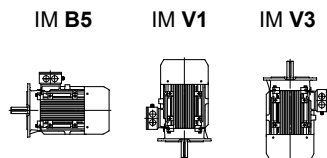

Mounting positions with feet

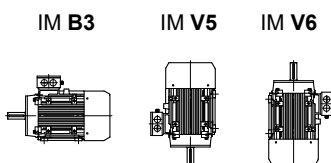

Main mating dimensions of the mounting positions with flange

Mounting position	Shaft end - Ø D x E Flange - Ø P						
	Motor size						
	IM	160	180	200	225	250	280
B3	42 x 110	48 x 110	55 x 110	60 x 140	65 x 140	75 x 140	80 x 170
B5	42 x 110 350	48 x 110 350	55 x 110 400	60 x 140 450	65 x 140 550	75 x 140 550	80 x 170 660
B5R	38 x 80 300	-	48 x 110 350	-	60 x 140 450	-	-

Construction features

Motor size	Bearing D-E 1)	Bearing N-D-E 1)	Housing	Flange		Endshield D-E N-D-E	Terminal box cover 3)	Seal 5)	Terminal block 4)	Cable gland	Fan cover	Cooling fan
				D-E	B5R							
160	6309-2RZ-C3	6309-2RZ-C3	LL	G	G	G	LL	45×60×8	M6	2×M40+1×M16	Painted	Plastic
180	6311-2RZ-C3	6311-2RZ-C3	G	G	-	G	G	VA55	M6	2×M50+1×M16		
200	6312-2RZ-C3	6312-2RZ-C3	G	G	G	G	G	VA60	M6	2×M50+1×M16		
225	6313-2RZ-C3	6313-2RZ-C3	G	G	-	G	G	VA65	M8	2×M50+1×M16		
250	6314-C3 ²⁾	6314-C3 ²⁾	G	G	-	G	G	VA70	M8	2×M50+1×M16		
280	6317-C3 ²⁾	6317-C3 ²⁾	G	G	-	G	G	VA85	M10	2×M63+1×M16		
315S	6319-C3 ²⁾	6319-C3 ²⁾	G	A	-	G	G	VA95	M12	2×M63+1×M16		

LL = light alloy.

G = cast iron. grey

A = steel

1) Lubricated for life assuming pollution free surroundings.

2) Greaser foreseen as standard D-E and N-D-E, hydraulic type Form A UNI 7663

3) Terminal box cover on housing with cable glands mounted on one side only, where:
one power cable gland and one for auxiliary devices with position 90° apart.

4) Terminal block with 6 terminals for cable terminal connection.

5) Sizes 160 seal ring; sizes 180 ... 315S V-ring.

Motor shaft specifications

Motor shaft made of steel C45 or equivalent; cylindrical shaft ends with A-shape (rounded) keyway and tapped butt-end hole, axially fastened on D-E side.

	Shaft end - Ø × E							
	Ø 38x80	Ø 42x110	Ø 48x110	Ø 55x110	Ø 60x140	Ø 65x140	Ø 75x140	Ø 80x170
d	M12	M16	M16	M20	M20	M20	M20	M20
b×h×l	10x8x70	12x8x100	14x9x100	16x10x100	18x11x130	18x11x130	20x12x130	22x14x160

d = tapped butt-end hole
b×h×l = key dimensions

Preload spring on non-drive end side, as standard.

Thermoplastic **cooling fan** with radial blades.

Earth terminal located inside terminal box; prearranged for the installation of a two further external earth terminals.

Rotor: pressure diecast cage in aluminium.

Stator winding with class F copper conductor insulation, insulated with double coat, type of impregnation with **VI** process, **class F insulation system**.

Materials and type of impregnation allow **use in tropical climates** without further treatment.

Rotor dynamic balancing: vibration velocity under standard rating A. Motors are balanced with half key inserted into shaft extension.

Paint: double-compound, water-soluble, polyacrylic resin based, corrosivity class C3 (to ISO 12844-2), colour blue RAL 5010 DIN 1843, unaffected by normal industrial environments and suitable for further finishings with double-compound synthetic paints.

For **non-standard designs** and accessories see ch. 7.7.

Compliance with European Directives

Motors of present catalog comply with following standards EN 60034-1, EN 60034-2, EN 60034-2-1, EN 60034-5, EN 60034-6, EN 60034-7, EN 60034-8, EN 60034-9, EN60034-12, EN 60034-14, IEC 60038, IEC 60072-1, and with **Low Voltage Directive 2014/35/EU** (repealing the old 73/23/EC). For this reason the electric motors are CE marked.

Additional information:

The motor design, considering the motors as components, complies with

- Machinery Directive 2006/42/EC when the installation is correctly executed by machinery manufacturer (e.g.: in compliance with our installation instructions and EN 60204 «Electric Equipments of Industrial Machines»);
- Directive 2011/65/EC RoHS relevant to the limit of use of dangerous substances in the electric and electronic equipments;
- Directive «ErP» 2009/125/EC establishing a framework for the setting of ecodesign requirements for energy-related products; on the base of the field of application, the motor are in conformity with requirements set in Regulation N° 640/2009 and subsequent modification No. 2019/1781 and the efficiency class is defined according to the Standard EN 60034-30.

Declaration of Incorporation (Directive 2006/42/EC Art. 7.2 – II B):

The above mentioned motors must be commissioned as soon as the machines in which they have been incorporated have been declared to be in compliance with the Machinery Directive.

According to EN 60034-1, as motors are components and not machines, supplied directly to the final user, the Electromagnetic Compatibility Directive (application of Directive 2014/30/EU) is not directly applicable.

7.4

Radial and axial loads on shaft end

Radial loads generated on the shaft end by a drive connecting motor and driven machine must be less than or equal to those given in the relevant table.

The radial load F_r given by the following formula refers to most common drives:

$$F_r = \frac{k \cdot 19100 \cdot P}{n \cdot d} \text{ [N]}$$

dove:

P [kW] is motor power required

n [min^{-1}] is the speed

d [m] è il diametro primitivo dispositivo calettato sull'albero

k is a coefficient assuming different values according to the drive type:

$k = 1$ for chain drive

$k = 1,1$ for gear pair drive

$k = 1,5$ for timing belt drive



$k = 2,5$ for V-belt drive

The table shows the maximum permissible values of radial and axial loads on driving shaft end (F_r , overhung load on centre line of shaft end), calculated for a bearing life $L_h = 18\,000$ h. For a longer bearing life, the values stated in the table must be multiplied by:

0,9 (25000 h),

0,8 (35500 h) or

0,71 (50000 h).

Motor size	$F_r^{(1)}$ [N]			$F_a^{(2)}$ [N]					
									
	n_N [min^{-1}]			n_N [min^{-1}]			n_N [min^{-1}]		
	3000	1500	1000	3000	1500	1000	3000	1500	1000
160M	-	3150	3650	-	2280	2670	-	1650	1960
160L	-	3750	4500	-	2000	2360	-	1000	1250
180M	-	-	-	-	-	-	-	-	-
180L	-	4000	4500	-	2000	2360	-	1120	1400
200	-	5300	6000	-	2500	3150	-	1120	1400
225	-	6000	6700	-	2800	3550	-	1700	2120
250	-	6700	7500	-	3350	4000	-	1700	2120
280	-	-	-	-	-	-	-	-	-
315S	-	-	-	-	-	-	-	-	-

1) An axial load of up to 0,2 times the value in the table is permissible, simultaneously with the radial load.

2) Comprehensive of a possible unfavourable effect of weight-force of rotor and bearing preload spring.

For running at 60Hz, table values must be reduced by 6%.

This page is intentionally left blank.

7.5

Technical data 400V 50 Hz

4 poli - 1500 min⁻¹

IP 55

IC 411

Insulation class F

Temperature rise class B

IE3
400V - 50Hz
ErP

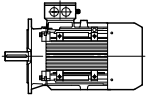

P _N kW	Motor	n _N min ⁻¹	M _N N m	I _N A 400 V	cos φ	η IE3 IEC 60034-2-1			M _S / M _N	M _{max} / M _N	I _S / I _N	J ₀ kg m ²	z ₀ starts/h	kg
						100%	75%	50%						
11	HE3 160 M 4	1470	71,5	21,5	0,81	91,4	92,7	92,4	2,4	3,35	7,8	0,09409	550	110
15	HE3 160 L 4	1475	97,1	29,9	0,79	92,1	92,4	91,5	2,2	3,45	8,5	0,11927	600	123
18,5	HE3 180 M 4	1470	120,2	34,9	0,83	92,6	92,8	92,2	1,9	3,5	6,1	0,166	390	211
22	HE3 180 L 4	1470	142,9	41,3	0,83	93	93,2	92,8	2	2,9	6,2	0,198	500	240
30	HE3 200 L 4	1470	194,9	54,6	0,85	93,6	94	93,4	1,9	2,75	6,6	0,32	250	235
37	HE3 225 S 4	1480	238,7	67,2	0,85	93,9	95	94,2	1,9	2,75	6,3	0,59	-	290
45	HE3 225 M 4	1480	290,3	81,5	0,85	94,2	93,8	89,7	2	2,9	6,8	0,69	-	330
55	HE3 250 M 4	1480	354,9	99,4	0,85	94,6	95,7	95,2	1,8	2,35	5,6	1,02	-	473

□ Temperature rise class F.

IE4
400V - 50Hz
ErP

P _N kW	Motor	n _N min ⁻¹	M _N N m	I _N A 400 V	cos φ	η IE4 IEC 60034-2-1			M _S / M _N	M _{max} / M _N	I _S / I _N	J ₀ kg m ²	z ₀ starts/h	kg
						100%	75%	50%						
75	HE4 280S 4	1490	480,7	129,6	0,87	96,0	96,2	93,1	2,0	2,3	8,5	1,472	-	619
90	HE4 280M 4	1490	576,8	153,6	0,88	96,1	96,3	93,2	2,0	2,3	8,5	1,677	-	682
110	HE4 315 S 4	1480	710,1	185,3	0,89	96,3	96,5	93,5	1,8	2,2	8,5	3,432	-	975

Technical data 400V 50 Hz

6 poli - 1000 min⁻¹
 IP 55
 IC 411
 Insulation class F
 Temperature rise class B

IE3
400V - 50Hz
ErP

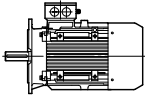

P _N kW	Motor	n _N min ⁻¹	M _N N m	I _N A 400 V	cos φ	η IE3 IEC 60034-2-1			M _S / M _N	M _{max} / M _N	I _S / I _N	J ₀ kg m ²	z ₀ starts/h	
						100%	75%	50%						
7,5	HE3 160 M 6	970	73,8	16,2	0,75	89,1	89,3	88,3	2,1	3,3	6,9	0,09965	1790	83
11	HE3 160 L 6	970	108,2	22,8	0,77	90,3	90,2	89,6	2,5	3,5	7,5	0,14308	1130	120
15	HE3 180 L 6	980	146,2	30,8	0,77	91,2	91,5	90,7	1,9	2,7	5,6	0,32608	690	232
18,5	HE3 200 LR 6	985	179,4	38,3	0,76	91,7	92,4	90,2	2	3,1	6,4	0,44133	360	220
22	HE3 200 L 6	980	214,4	43,6	0,79	92,2	92,3	89,4	1,9	2,5	7	0,51	-	230
30	HE3 225 M 6	985	290,9	57,5	0,81	92,9	93	90,1	2	2,3	7,2	0,81	-	300
37	HE3 250 M 6	985	358,7	69	0,83	93,3	93,4	90,5	2,3	3	7,3	1,2	-	410
45	HE3 280 S 6	990	434,1	84,5	0,82	93,7	93,8	90,9	2,3	2,7	7,4	2,34	-	586
55	HE3 280 M 6	990	530,6	101,6	0,83	94,1	94,2	91,3	2,3	2,8	7,5	2,8	-	665

IE4
400V - 50Hz
ErP

P _N kW	Motor	n _N min ⁻¹	M _N N m	I _N A 400 V	cos φ	η IE4 IEC 60034-2-1			M _S / M _N	M _{max} / M _N	I _S / I _N	J ₀ kg m ²	z ₀ starts/h	
						100%	75%	50%						
75	HE4 315S 6	985	727,5	135,1	0,84	95,4	95,6	92,5	1,6	2,0	8,0	3,417	-	861

7.6

Motor dimensions

Mounting position
IM B5, IM B5R

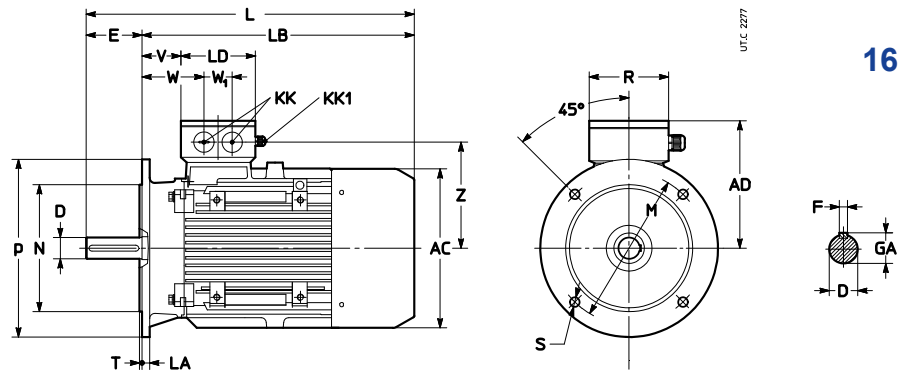

160 ... 315

Motor size	AC	AD	L	LB	LD	KK	KK1	R	V	W	W ₁	Z	Shaft end				Flange									
													D	E	F	GA	M	N	P	LA	S	T				
	∅												∅	h9	∅	∅	∅	∅	∅	∅	∅					
160 B5R B5	315	240	620	540	150	2×M40	1×M16	160	92	140	56	210	38	k6	M12	80	10	41	265	230	j6	300	14	14	4	
			650																							
180 M 180 L	360	278	660	550	158	2×M50		169	81	130	60	225	48	k6	M16		14	51,5								
					700				590																	
200 B5R B5	400	310	795	685	198			218	123	185	72	250														
									760	650																
225 S 225 M	450	330	795	655					91	153		272	60	m6	M20	140	18	64	400	350	h6	450	20	19 ⁴⁾		
					820				680																	
250 B5R B5	485	375	876	736	228			228	93	162	90	295														
280S 280M	550	405	1013	873		2×M63			101	170		324	75	m6	M20		20	79,5								
					1064				928																	
315S	620	530	1185	1015	303			303	106	197	120	433	80	m6	M20	170	22	85	600	550	h6	660		24 ⁴⁾	6	

1) Tapped butt-end hole.

4) 22° 30' rotation of 8 holes compared to scheme.

Mounting position
IM B3

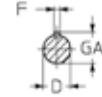
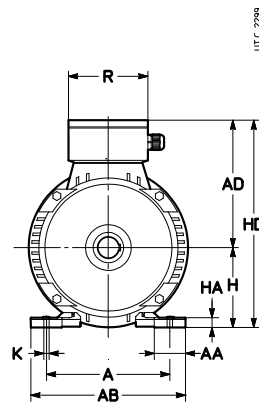
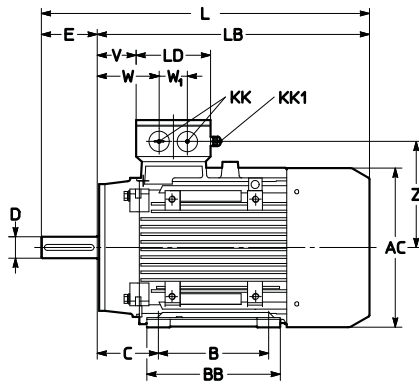

160 ... 315

Motor size												Shaft end				Feet											
	AC	AD	L	LB	LD	KK	KK1	R	V	W	W ₁	Z	D	1)	E	F	GA	A	AB	B	C	BB	AA	K	HA	H ²⁾	HD
	∅												∅		h9												
160 M B3	315	240	650	540	150	4×M40	1×M16	160	82	140	56	210	42 k6	M16	110	12	45	254	296	254	108	296	55	14	20	160	418
160L B3																											
180 M B3	360	278	660	550	158	2×M50		169	81		60	225	48 k6	M16		14	51,5	279	350	241	121	315	70	15	22	180	458
180 L B3			700	590																279							
200 B3	400	310	760	650	198			218	88	150	72	250	55 m6	M20		16	59	318	390	305	133	370	70	19	25	200	510
225 S B3	450	330	795	655					91	153		272	60 m6	M20	140	18	64	356	435	286	149		75		28	225	555
225 M B3			820	680																311	395						
250 B3	485	375	876	736	228			228	93	162	90	295	65 m6	M20			69	406	485	349	168	445	80	24	30	250	625
280 S B3	550	405	1013	873		2×M63			101	170		324	75 m6	M20		20	79,5	457	545	368	190	490	85		35	280	685
280 M B3			1064	928																419	540						
315 S B3	620	530	1185	1015	303			303	106	197	120	433	80 m6	M20	170	22	85	508	630	406	216	570	120	28	45	315	845

1) Tapped butt-end hole.

2) Tolerance: up to size 250 ± 0.5 mm, for sizes 280 and 315 ± 1 mm.

7.7

Non-standard designs and accessories

Ref.	Description	Non-standard design code
(1)	Non-standard motor supply	–
(3)	Insulation class H	,H
(8)	Condensate drain holes	,CD
(9)	Additional winding impregnation	,SP
(13)	Anti-condensation heater	,S
(14)	Terminal box on one side (IM B3 and derivatives)	,P...
(17)	Axial independent cooling fan	,V...
(18)	Axial independent cooling fan and encoder	,V... ,E...
(20)	Bi-metal type thermal probes	,B15
(21)	Drip-proof cover	,PP
(35)	Light alloy fan	,VL
(36)	Encoder	,E1 ... ,E5
(51)	Strengthened design for supply from inverter	,IR
(62)	Motor pre-arranged for encoder	,PE
(63)	Axial independent cooling fan and prearranged for encoder	,V... ,PE...
(64)	IP 66 protection	,IP 66

(1) Non-standard motor supply

The first two columns show the possible types of supply.

Supply of independent cooling fan is **co-ordinated** with motor winding voltage as stated in the table.

Motor wound and stated for		160M ... 315
	Hz	
Δ 380	50	●
Δ 400	50	●
Δ 415	50	●
Δ 440	60	○
Δ 460	60	●
Δ 480	60	●

● standard ○ on request

Designation: following the instructions at ch. 7.2, state **voltage** and **frequency** (in the first table columns).

(3) Insulation class H

Insulation materials in class H with permissible temperature rise in class H.

Thermistor thermal probes are supplied as standard with an intervention temperature of 170 °C (, T17).



Non-standard design code for the **designation:** ,H

(8) Condensate drain holes

It is advisable for motors operating in particularly damp environments and/or with wide variation in the temperature and/or at low temperature. In motor designation state in «MOUNTING POSITION» the designation of the real application mounting position, determining the hole position.

Motors are supplied with closed holes.

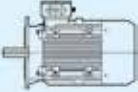
Non-standard design code for the **designation:** ,CD

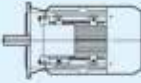
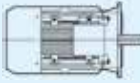
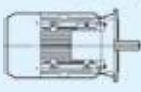
Mounting position						
B3	IM 1001	IM 1011	IM 1031	IM 1051	IM 1061	IM 1071
B5	IM 3001	IM 3011	IM 3031	IM 3051	IM 3061	IM 3071

Design supplied as standard 180 ... 315.

(9) Additional winding impregnation

It consists of a second impregnation cycle after stator windings assembly standard supplied with design (64).

Useful where it is necessary to have an additional protection (of the windings) against electrical stress (voltage peaks due to rapid commutations or to «low quality» inverters with high voltage gradients) or mechanical agents (mechanical or electromagnetic vibrations: e.g. from inverter). See also ch. 2.9 «Voltage peaks (U_{max}), voltage gradients (dU/dt), cable length».

Non-standard design code for the **designation:** ,SP

(13) Anti-condensation heater

It is advisable for motors operating in particularly damp environments and/or with wide variation in the temperature and/or at low temperature; supply and power absorbed, see table below.

Motor size	Heater [W]	V a.c. ~ supply
160	50	230 V 50 / 60 Hz ± 10%
180, 225	80	
250 ... 280	100	
315	130	

Heater must not be connected during the running.
Cables connected to fixed or loose terminal block inside terminal box.
Non-standard design code for the **designation: ,S**

(14) Terminal box on one side (for IM B3 and derivatives)

Terminal box in position P1 or P2.

Non-standard design code for the **designation:**
,P... (additional code **1** or **2** according to scheme beside).

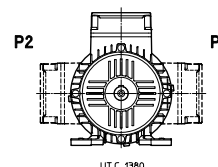

(17) Axial independent cooling fan

Cooling provided by axial independent cooling fan, **compact** for variable speed drives (motor can absorb nominal current for all speed range, in continuous duty cycle and without overheating) with inverter and/or for heavy starting cycles (for Z_0 increases consult us).

The supply of the independent cooling fan is according to the table below.
LB dimensions **increase** (see ch. 7.7) by ΔLB quantity as per following table.

Specifications of independent cooling fan:

- Three phase Y only supply
- **IP 55** protection
- supply terminals on proper auxiliary terminal block in the motor terminal box

Non-standard design code for the **designation: ,VD ,VM**

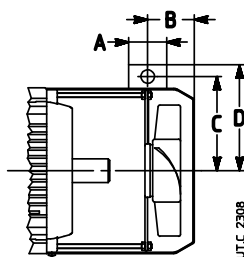

Motor size wound and stated for			Independent cooling											
Motor size	V	Hz	Independent cooling fan name plate					kg	ΔLB	A	B	C	D	Code
			V	Hz	W	A	cos φ							
160	Y380	50	Y380	50	50	0,13	0,59	7	135	74	113	189	207	,VD
	Y400		Y400		55	0,14	0,56							
	Y415		Y415		55	0,15	0,54							
	Y440	60	Y440	60	75	0,15	0,69							
	Y460		Y460		75	0,15	0,66							
	Y480		Y480		80	0,16	0,63							
180	Y380	50	Y380	50	65	0,15	0,7	8	110	74	107	210	228	
	Y400		Y400		70	0,16	0,67							
	Y415		Y415		75	0,16	0,65							
	Y440	60	Y440	60	95	0,16	0,79							
	Y460		Y460		100	0,17	0,76							
	Y480		Y480		105	0,17	0,75							
200	Y380	50	Y380	50	80	0,15	0,78	9	120	74	120	231	249	
	Y400		Y400		80	0,16	0,76							
	Y415		Y415		85	0,16	0,75							
	Y440	60	Y440	60	115	0,18	0,84							
	Y460		Y460		120	0,18	0,83							
	Y480		Y480		125	0,19	0,81							
225	Y380	50	Y380	50	160	0,38	0,68	13	150	74	152	256	274	
	Y400		Y400		165	0,39	0,65							
	Y415		Y415		170	0,4	0,63							
	Y440	60	Y440	60	240	0,43	0,78							
	Y460		Y460		245	0,44	0,75							
	Y480		Y480		255	0,45	0,74							
250	Y380	50	Y380	50	200	0,6	0,52	15	160	74	154	276	294	
	Y400		Y400		205	0,63	0,49							
	Y415		Y415		210	0,67	0,46							
	Y440	60	Y440	60	285	0,63	0,61							
	Y460		Y460		290	0,67	0,59							
	Y480		Y480		300	0,69	0,56							
280	Y380	50	Y380	50	165	0,56	0,48	20	170	125	152	315	355	
	Y400		Y400		175	0,59	0,45							
	Y415		Y415		180	0,6	0,43							
	Y440	60	Y440	60	250	0,58	0,6							
	Y460		Y460		255	0,6	0,57							
	Y480		Y480		260	0,62	0,54							
315	Y380	50	Y380	50	375	0,8	0,73	32	185	125	184	251	391	
	Y400		Y400		375	0,8	0,7							
	Y415		Y415		375	0,8	0,68							
	Y440	60	Y440	60	600	1,09	0,8							
	Y460		Y460		600	1,09	0,79							
	Y480		Y480		600	1,09	0,77							

Non-standard design code for the designation: ,VD ,VM.

(18) Axial independent cooling fan and encoder

Independently cooled motor equipped with hollow shaft **encoder** with elastic fastening.

For specifications and designation code relevant to the independent cooling fan and the encoder see design (17) and design (36), respectively.

Motor overall dimensions as «Axial independent cooling fan» design (17).

Non-standard design code for the **designation**: ,V ... ,E...

IC 416 is stated on name plate

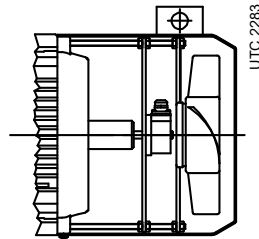

(20) Bi-metal type thermal probes

Three bi-metal probes wired in series with usually closed contact inserted in the windings. Nominal current 1,6 A, nominal voltage 250 V a.c.. The contact opens when (delay 20 ÷ 60 s) the temperature of the windings reaches the setting temperature of **150 °C** (B15).

With design (3) «Insulation class H» if required, **bi-metal probes** with setting temperature of 170 °C (**B17**) are supplied.

Terminals connected to a loose or fixed terminal block inside the terminal box.

Non-standard design code for the **designation**: ,B15

(21) Drip-proof cover

Necessary design for outdoor applications or when water sprays are present, in mounting position with downwards vertical shaft (IM V1, IM V18).

LB dimension (see. ch. 7.6) increases by ΔLB stated in table:

Non-standard design code for the **designation**: ,PP

Motor size	ΔLB [mm]
160 ... 225	60
250 ... 280	80
315	100

(35) Light alloy fan

Motor with light alloy fan (aluminum) for environments where it is not advisable to use the standard plastic fan.

Non-standard design code for the **designation**: ,VL

(36) Encoder

Motor equipped with incremental hollow shaft encoder and elastic fastening with the following features stated in the table (free connection wirings for the use of connectors installed by the Buyer). For different and/or additional specifications consult us.

LB dimension (see ch. 7.6) **increases** by ΔLB quantity given in the table.

Motor size	Encoder ΔLB [mm]
160	55
180	62
200	70
225	70
250	60
280	54
315	60

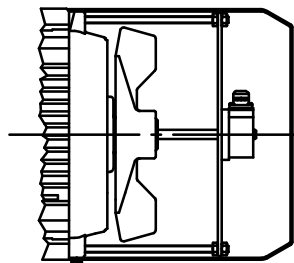

Output signal ¹⁾	RS 422 LD TTL	RS 422 TTL	Push - Pull HTL LD HTL	sin / cos	
	Supply voltage U_B	5 V d.c. \pm 5%	10 \div 30 V d.c.		5 V d.c. \pm 5%
Maximum current consumption (without load) I_N	90 mA		100 mA	110 mA	
Channels	A+, A-, B+, B-, 0+, 0-				
Output amplitude per track	$U_l \leq 0,5 V_{dc}$; $U_h \geq 2,5 V_{dc}$		$U_l \leq 0,5 V_{dc}$; $U_h \geq U_B - 1 V_{dc}$		1 $V_{pp} \pm 20\%$ (channel A, B) 0,1 \div 1,2 V (channel 0)
Maximum output current per track I_{out}	± 20 mA		± 30 mA		-
Maximum pulse frequency f_{max}	100 \div 300 kHz ^{2) 3)}				-
Frequency -3 dB	-				≥ 180 kHz
No. pulse per revolution	1024 ⁴⁾				
Vibration resistance (DIN-IEC 68-2-6)	≤ 100 m/s ² , 10 ... 2000 Hz				
Shock resistance (DIN-IEC 68-2-27)	$\leq 1000 \div 2500$ m/s ² , 6 ms ²⁾			≤ 2000 m/s ² , 6 ms	
Maximum speed	6000 min ⁻¹				
Ambient temperature	-40 °C \div 100 °C	-30 °C \div 85 °C	-40 °C \div 100 °C	-25 °C \div 85 °C	
Protection degree (EN 60 529)	IP65				
Connections	free cables ⁸⁾ L = 1000 mm for use of connector installed by the user				
Encoder cable cross-sections	2 \times 0,22+6 \times 0,14 [mm ²]	10 \times 0,14 [mm ²]	2 \times 0,22+6 \times 0,14 [mm ²]	8 \times 0,22 [mm ²]	8 \times 0,22 [mm ²]
Code for designation	,E1	,E2	,E3	,E4	,E5

1) Other electronic configurations available on request; consult us.

2) Variable depending on the model.

3) Parameter to be checked depending on the combination max motor speed/pulse per revolution required.

4) Other pulse rates available on request (max 5000 ppr).

8) On request: different cable lengths, output with connector or with connector and cable; consult us.

Non-standard design code for the **designation**: ,E1 ... ,E5 (see table).

(51) Strengthened design for supply from inverter

Advised or necessary (see ch. 2.9 «Voltage peaks (U_{max}), voltage gradients (dU/dt), cable length») for inverter supply voltages $U_N > 400$ V, voltage peaks $U_{max} > 1000$ V, voltage gradients $dU/dt > 1$ kV/ μ s, supply cable length between inverter and motor > 30 m. For sizes 280, 315 this design becomes necessary also for $U_N \leq 400$ V.

It consists of special winding and impregnation cycle; for sizes 280, 315 also strengthened insulation, insulated bearing on non-drive end (to avoid shaft currents generated by supply from inverter).

«Inverter duty ,IR» stated on name plate

Non-standard design code for the **designation: ,IR**

(62) Motor prearranged for encoder

Motor prearranged for encoder with following features:

- anti-rotation center distance $\varnothing 63$ mm;
- flexible anti-rotation bracket with 1 or 2 holes/slots at 180° suitable for screw passage M3;
- max encoder height 48 mm;
- motor shaft $\varnothing 10$ h6 mm.

Motor dimensions as design (36).

Non-standard design code for the **designation: ,PE**

(63) Axial independent cooling fan and prearranged for encoder

Independently cooled motor prearranged for encoder with following features:

- anti-rotation center distance $\varnothing 63$ mm;
- flexible anti-rotation bracket with 1 or 2 holes/slots at 180° suitable for screw passage M3;
- max encoder height 48 mm;
- motor shaft $\varnothing 10$ h6 mm and length 35 mm.

For specifications and independent cooling fan designation code see design (17).

Motor overall dimensions as «Axial independent cooling fan» (17).

Non-standard design code for the **designation: ,V... ,PE**

IC 416 is stated on name plate

(64) IP 66 protection

Advised for installation in environments as stated in the table below, including relevant limitations.

Environment type	Non-standard designs		
	(17)	(18)	(36)
Outdoor			
In damp environment			
In case of condensate			
In sea or aggressive environment	○	○	○
In case of direct bolts/ water splash			
In dusty environment			●

● Possible ○ Consult us

Apply adhesive between housing and endshield mating surfaces (to be re-adjusted when disassembling the motor).

In these cases it is advised to require the following designs as well:

«Condensate drain holes» (8)

«Anti-condensation heaters» (13)

Non-standard design code for **designation: ,IP 66**

Supply of independent cooling fan is **co-ordinated** with motor winding voltage as stated in the table.

- (1) Number of phases
- (2) Motor type
- (3) Size
- (4) Number of poles
- (5) Designation of mounting position
- (6) Protection IP ...
- (7) Maximum ambient temperature
- (8) Code IC
- (9) Production number
- (10) Two months and year of manufacturing end serial number
- (11) Motor mass
- (12) Insulation class I.CL....
- (13) Duty cycle S...
- (14) Motor code
- (15) Customer code *
- (16) Bearings
- (17) Note 1
- (18) Note 2
- (19) Connection of the phases
- (20) Nominal voltage
- (21) Voltage tolerance
- (22) Nominal frequency
- (23) Frequency tolerance
- (24) Nominal current
- (25) Nominal power
- (26) Nominal speed
- (27) Nominal power factor
- (28) Nominal efficiency IEC 60034-2-1
- (29) Design - code

* On request

MOT. (1)~ (9)	(2) (3) (4) (5) (10)	IP (6)	AMB. (7)	IC (8)			
(14)	Brake Nm	kg (11)	I.CL. (12)	S (13)			
(15)		V~/Hz	A	#DA#	V=		
DE/NDE (16)							
(17) (18)							
(19) V (19)	%	Hz	%	A	kW	min ⁻¹	cos φ
(20)	(21)	(22)	(23)	(24)	(25)	(26)	(27)
(28)							
(29)							

UTC 2288

Motor wound and stated for		Motor size
V	Hz	160 ... 315
Δ 380	50	●
Δ 400	50	●
Δ 415	50	●
Δ 460	60	●
Δ 480	60	●

● Standard nameplate

160 ... 315

MOT. 3 ~	HE3 160L 4 B5	IP 55	AMB. 40°C	IC 411			
1642457 01/19	4598127	kg 125	I.CL. F	S 1			
R000111170	Brake Nm	V~/Hz	A	#DA#	V=		
CUSTOMER							
DE/NDE 6309-2Z-C3/6309-2Z-C3							
(17) (18)							
Δ V	%	Hz	%	A	kW	min ⁻¹	cos φ
380		50		30.1	15	1460	0.82
400		50		29.5	15	1465	0.80
415		50		29	15	1470	0.78
460		60		25.5	15 SF1.15	1770	0.79
480		60		25.2	15 SF1.2	1775	0.77
50/60Hz: IE3 92.1/93.0(100%) 91.9/92.8(75%) 92.1/92.4(50%)							
60Hz NEMA NOM. EFF. 93% 20 hp DES.C CODE.A/A							

UTC 2290

Brake motor for gearmotors HEZ

Section Contents

8.1	General specifications	198
8.2	Designation	199
8.3	Specifications	199
8.4	Radial and axial loads on shaft end	202
8.5	Motor brake specifications HEZ	203
8.6	Technical data 400V 50Hz	204
8.7	Motor dimensions	206
8.8	Non-standard designs and accessories	208
8.9	Name plate	216

8.1

General specifications

Brake motor with direct current brake for gearmotors

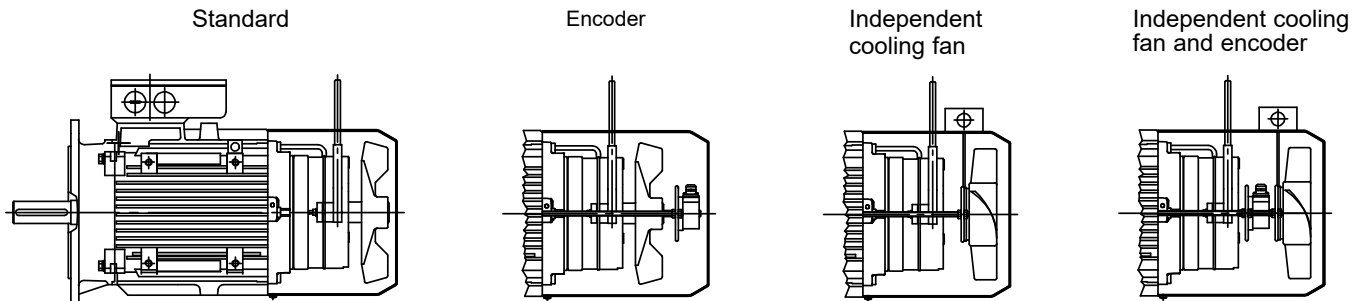

- Series of brake motors with d.c. suitable for universal use and especially for gearmotors' applications.
- Sizes 160 ... 200
- Class F insulation; temperature rise class B or F
- Mounting position **IM B3**, **IM B5** and derivatives.
- **IP 55** protection
- **Particularly strong construction** (both electrical and mechanical) suitable for to withstand alternating torsional and thermic stresses of starting and braking;
- **Suitable for operation with inverter**
- **Asbestos-free** friction surfaces
- Double braking surface, braking torque proportioned to motor torque (usually $M_f \approx 2M_N$)
- **Maximum operation progressivity** (both at starting and braking) thanks to a lower rapidity (**typical of d.c. brake**) of the anchor (which is lighter and less quick in the impact): motor starts slightly braked i.e. with greater progressivity; good release and braking rapidity; possibility to increase rapidity when braking, with supply opening on d.c. side
- High braking capacity.
- Particularly suitable for applications requiring regular and low-noise starting and braking and, at the same time, braking with good rapidity and precision and high number of starts

The following designs are **standard** for the whole range:

- **Cable glands already assembled** oriented to nameplate
- **Axial fastening on opposite drive end**
- **Thermistor type thermal probes (PTC) 150 °C**
- **Suitable for operation with inverter**
- **Three types of voltages stated on nameplate**
- **Standard condensate drain holes for sizes 180, 200**
- **suitable for mounting position B3 ,B8.**
- (For B5 motor n. 1 hole on flange and n. 2 holes on housing respectively on drive end and non drive end.
- For B3 and B5R motor n. 2 holes on housing respectively on drive end and non drive end)
- **Terminal box connection already Δ -prearranged connection**
- **NEMA MG 1-12 references stated on nameplate**
- **Manual release lever with automatic return**

Designation

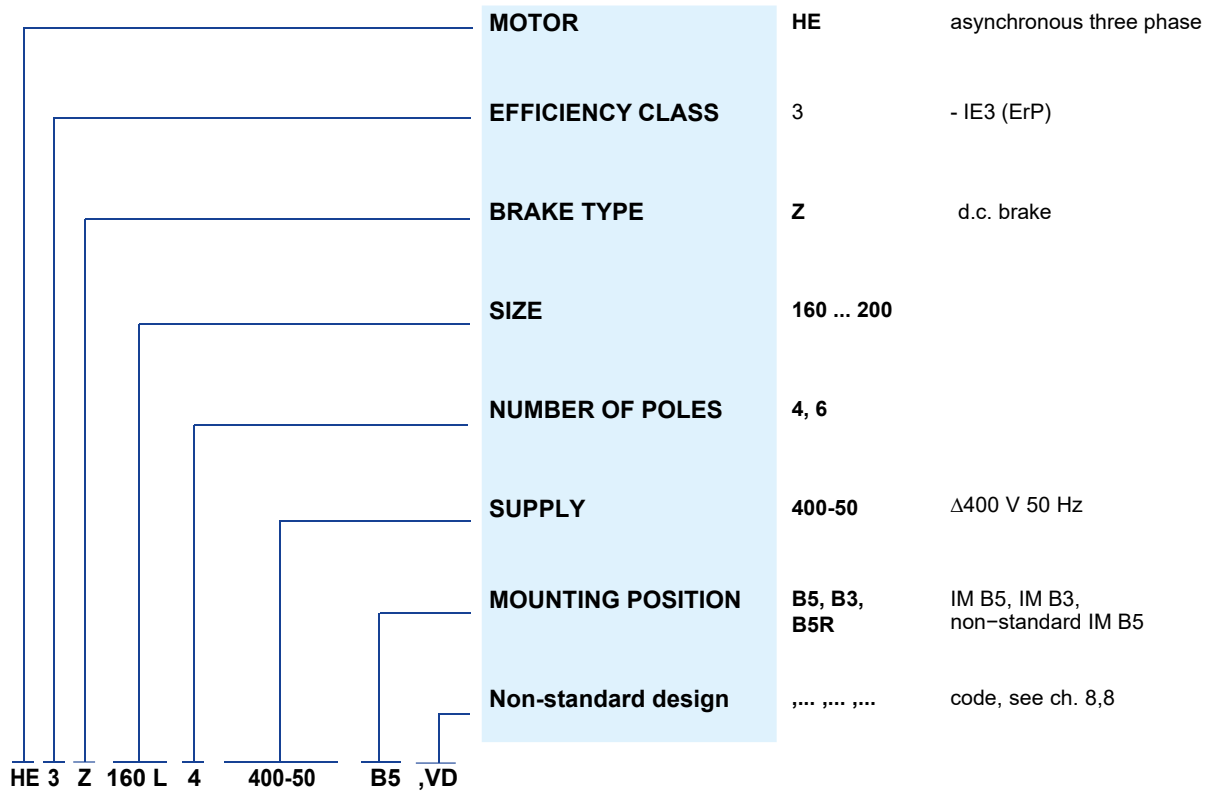

Specifications

Asynchronous three-phase electric **brake motor** with **d.c. brake** (braking in case of failure of supply) with double braking surface

Standardised motor with cage rotor, totally enclosed, externally ventilated (cooling system IC 411), single-speed according to following tables:

Number of poles	Winding	Motor size	Standard supply		insulation	Class temperature rise
			50 Hz	60 Hz		
4, 6	three-phase Δ	160 ... 200	Δ 380 V	F	B ¹⁾	
			Δ 400 V			
			Δ 415 V			
			Δ 460 V			
			Δ 480 V			

1) Excluding some motors (identified by □ at ch. 8.6 and 8.7) whose temperature rise class is F.

Rated power delivered on continuous duty (S1) and at standard voltage and frequency; ambient temperature -15 ÷ +40 °C, altitude < 1000 m.

IP 55 protection

Mounting positions IM B5; motors can also operate in the relevant mounting positions with vertical shaft, which are respectively (see following table): IM V1 and IM V3; the name plate shows the designation of mounting position with horizontal.

Mounting positions with flange

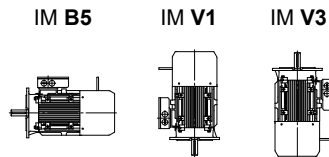

Mounting positions with feet

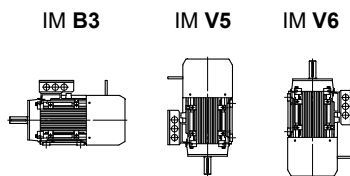

Main mating dimensions of the mounting positions with flange

Mounting position	Shaft end - Ø D x E Flange - Ø P		
	Motor size		
IM	160	180	200
B3	42 x 110	48 x 110	55 x 110
B5	42 x 110 350	48 x 110 350	55 x 110 400
B5R	38 x 80 300	-	48 x 110 350

Construction features

Motor size	Bearing D-E 1)	Bearing N-D-E 1)	Housing	Flange		Endshield D-E N-D-E	Terminal box cover 3)	Seal 5)		Terminal block 4)	Cable gland	Fan cover 6)	Cooling fan 7)
				B5	B5R			D-E	N-D-E				
160	6309-2RZ	6309-2RZ-C3	LL	G	G	G	LL	45×60×8	VA45	M6	2×M40+1×M16		
180	6311-2RZ-C3	6311-2RZ-C3	G	G	-	G	LL	VA55	VA55	M6	2×M50+1×M16	6)	7)
200	6312-2RZ	6310-2RZ-C3	G	G	G	G	LL	VA60	VA60	M6	2×M50+1×M16		

LL = light alloy.

G = cast iron.

1) Lubricated for life assuming pollution free surroundings.

3) Terminal box cover pre-arranged for cable glands mounting on both sides.

Cable glands assembled on one side only, one power type and one for auxiliary devices.

4) Terminal block with 6 terminals for cable terminal connection.

5) D-E sizes 160: seal ring;

D-E sizes 180 ... 200: V-ring.

N-D-E sizes 160 ... 200: V-ring

6) Painted

7) Plastic

Motor shaft specifications

Motor shaft made of steel C45 or equivalent; cylindrical shaft ends with A-shape (rounded) keyway and tapped butt-end hole, axially fastened on N-D-E side.

	Shaft end - Ø × E			
	Ø 38x80	Ø 42x110	Ø 48x110	Ø 55x110
d	M12	M16	M16	M20
b×h×l	10x8x70	12x8x100	14x9x100	16x10x100

d = tapped butt-end hole
b×h×l = key dimensions

Preload spring drive end as standard.

Thermoplastic **cooling fan** with radial blades.

Earth terminal located inside terminal box; prearranged for the installation of a further external earth terminal on housing.

Brake supply: with rectifier laying in terminal box having 2 terminals for cable connection for rectifier supply and 2 for external contact of fast braking; possible brake supply **directly from motor terminal block** or **separately** (to be used for: motors supplied by inverter, separate drive needs of motor and brake, etc.).

Brake can be supplied, also at motor standstill, with no time limitations.

Pressure diecast cage **rotor** in aluminium.

Stator winding with class F copper conductor insulation, insulated with double coat, type of impregnation with VI process, **class F insulation system**.

Rotor dynamic balancing: vibration velocity under standard rating A. Motors are balanced with half key inserted into shaft extension.

Paint: double-compound, water-soluble, polyacrylic resin based, corrosivity class C3 (to ISO 12844-2), colour blue RAL 5010 DIN 1843, unaffected by normal industrial environments and suitable for further finishings with double-compound synthetic paints.

For **non-standard designs** and accessories see ch. 8.8.

Compliance with European Directives

Motors of present catalog comply with following standards: EN 60034-1, EN 60034-2-1, EN 60034-2, EN 60034-5, EN 60034-6, EN 60034-7, EN 60034-8, EN 60034-9, EN60034-12, EN 60034-14, IEC 60038, IEC 60072-1, and with **Low Voltage Directive 2014/35/EU**.

For this reason the electric motors are CE marked.

Additional information:

The motor design, considering the motors as components, complies with

- Machinery Directive 2006/42/EC when the installation is correctly executed by machinery manufacturer (e.g.: in compliance with our installation instructions and EN 60204 «Electric Equipments of Industrial Machines»);
- Directive 2011/65/EC RoHS relevant to the limit of use of dangerous substances in the electric and electronic equipments.
- Directive «ErP» 2009/125/EC establishing a framework for the setting of ecodesign requirements for energy-related products; on the base of the field of application, the motor are in conformity with requirements set in Regulation N° 640/2009 and subsequent modification No. 2019/1781 and the efficiency class is defined according to the Standard EN 60034-30.

Declaration of Incorporation (Directive 2006/42/EC Art 8.2 - II B):

The above mentioned motors must be commissioned as soon as the machines in which they have been incorporated have been declared to be in compliance with the Machinery Directive.

According to EN 60034-1, as motors are components and not machines, supplied directly to the final user, the Electromagnetic Compatibility Directive (application of Directive 2014/30/EU) is not directly applicable.

8.4

Radial and axial loads on shaft end

Radial loads generated on the shaft end by a drive connecting motor and driven machine must be less than or equal to those given in the relevant table.

The radial load F_r given by the following formula refers to most common drives:

$$F_r = \frac{k \cdot 19100 \cdot P}{n \cdot d} \text{ [N]}$$

where:

P [kW] is motor power required

n [min^{-1}] is the speed

d [m] is the pitch diameter

k is a coefficient assuming different values according to the drive type:

$k = 1$ for chain drive

$k = 1,1$ for gear pair drive

$k = 1,5$ for timing belt drive

$k = 2,5$ for V-belt drive

The table shows maximum permissible values of radial and axial loads on driving shaft end (F_r overhung load on centre line of shaft end), calculated for a bearing life $L_n = 18\,000$ h. For a longer bearing life, the values stated in the table must be multiplied by:

0,9 (25000 h),

0,8 (35500 h) or

0,71 (50000 h).

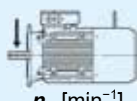
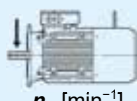
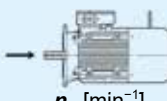
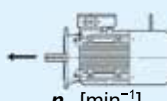
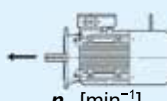
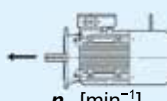
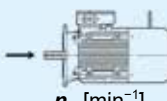
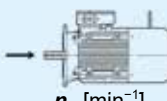
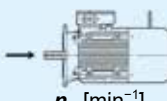
Motor size	$F_r^{1)}$ [N]			$F_a^{2)}$ [N]					
									
	n_N [min^{-1}]	n_N [min^{-1}]	n_N [min^{-1}]	n_N [min^{-1}]	n_N [min^{-1}]	n_N [min^{-1}]	n_N [min^{-1}]	n_N [min^{-1}]	n_N [min^{-1}]
	3000	1500	1000	3000	1500	1000	3000	1500	1000
160	-	3750	4500	-	2000	2360	-	1000	1250
180	-	4000	4500	-	2000	2360	-	1120	1400
200	-	5300	6000	-	2500	3150	-	1120	1400

1) An axial load of up to 0,2 times the value in the table is permissible, simultaneously with the radial load.

2) Comprehensive of a possible unfavourable effect of weight-force of rotor and bearing preload spring.

For running at 60 Hz, table values must be reduced by 6%.

Motor brake specifications HEZ

Electromagnetic spring loaded brake (braking occurs automatically when it is not supplied), with **d.c.** toroidal coil and double braking surface, braking torque **proportioned** to motor torque (usually $M_f \approx 2 M_N$).

Conceived for **maximum reduced noise level of running** and **progressivity** of on-off switching (both when starting and when braking thanks to lower rapidity, typical of d.c. brake, of brake anchor, lighter and less quick in the impact: motor starts slightly braked and with greater progressivity) **with increased rapidity in releasing and braking**; possibility to increase the rapidity, both in releasing (with rapid rectifier) and braking with supply opening on d.c. side, outstanding work capacity.

Particularly suitable for applications requiring regular and low-noise starting and braking and, at the same time, braking with good rapidity and precision and high number of starts.

When electromagnet is not supplied, the brake anchor pushed by springs presses the brake disk on rear endshield generating the braking torque on the same brake disk and consequently on motor shaft it is keyed onto; by supplying the brake the electromagnet draws the brake anchor and releases the brake disk and driving shaft.

Main specifications:

- alternate single-phase **supply voltage** of rectifier (always supplied in terminal box)
- **400 V ± 5% 50 or 60 Hz simple half-wave rectifier**;
- rectifier supply **separatly from motor terminal block**;
- braking torque adjustable by changing number of springs;
- **insulation class F, temperature rise class B**;
- brake disk, sliding on moving hub: with single steel coat and double friction surface with average friction coefficient for low wear;
- **brake anchor in two pieces** for greater rapidity of starting and reduced noise;
- **water-proof and dust-proof gaiter** and **V-ring** both to prevent polluting infiltrations from surroundings towards brake, and to avoid that wear dust of friction surface will be dispersed in the surroundings;
- **lever for manual release with automatic return** and removable level rod;
- for other functional specifications see following table.

For main specifications of motor see ch. 8.6.

For non-standard designs see ch. 8.8.

Motor is **always equipped with a high reliable rectifier** fixed on terminal box providing adequate connecting terminals (2 for rectifier supply separatly from motor terminal block or directly; 2 for external contact of rapid braking).

RR1 rectifier (standard for) is a single half-wave diode bridge (output d.c. voltage $\approx 0,45$ a.c. supply voltage) running at double half-wave for the approximately initial 600 ms supplying a double voltage to the brake coil, and allowing to have a quick brake release.

All rectifier models can be connected-disconnected both on a.c. side (for maximum low noise running); both on a.c. and d.c. side (for a quicker braking release) as they are equipped with varistors for the protection of diodes, electromagnet and d.c. side opening contact (wiring schemes see ch. 9).

Table of main functional specifications of brake

Effective values may slightly differ according to ambient temperature and humidity, brake temperature and state of wear of friction surface.

Brake size	Motor size	$M_f \pm 12\%$ Spacer number (primed) N m	Absorption			Delay of ²³⁾			Air-gap		W_1 MJ/mm 26)	C_{max} mm 27)	$W_{max}^{28)}$ [J]					
			V c.a	A c.a. max	W	release	braking		mm nom	mm max			brakings/h					
						t_1 ms 24)	t_2 ms	t_2 C.C. ms 25)					10	100	1000			
BC 08	RR1 ²⁹⁾	160M	85 ³⁾	170 ⁶⁾	250 ⁹⁾	400	0,56	125	150	300	30	0,40	0,60	450	6	28000	7100	1000
BC 09	RR1 ²⁹⁾	180M ... 200	200 ⁶⁾	300 ⁹⁾	400 ¹²⁾	400	0,67	140	200	450	40	0,50	0,70	630	6	40000	10000	1400

21) Standard rectifier, supplied as standard; stop time must be **2,5 s ÷ 3,5 s**. If necessary, consult us.

23) Values valid with M_{fmax} , mean air-gap and nominal value of supply voltage.

24) Release time of brake obtained with standard rectifier.

25) Braking delay obtained by separate brake supply and coil disconnection on a.c. side of rectifier (t_2) or on a.c. and d.c. side (t_2 d.c.). With direct supply from motor terminal block, the values of t_2 increase of approx. 2,5 times the ones of table.

26) Friction work for brake disk wear of 1 mm (minimum value for heavy duty; real value is usually greater).

27) Maximum brake disk wear.

28) Maximum friction work for each braking.

29) In case of rectifier supply ≥ 400 V a.c. with disconnection on a.c. and d.c. side at high number of start use RR8 rectifier (see ch. 8.9 (26)).

8.6

Technical data 400V 50 Hz

4 poli - 1500 min⁻¹
 IP 55
 IC 411
 Insulation class F
 Temperature rise class B

IE3
400V - 50Hz
ErP

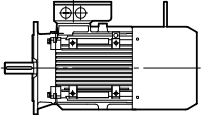

P _N kW	Motor	n _N min ⁻¹	M _N N m	I _N A 400 V	cos φ	η IE3 IEC 60034-2-1			M _S / M _N	M _{max} / M _N	I _S / I _N	J ₀ kg m ²	Brake M _f N m	z ₀ starts/h	kg
						100%	75%	50%							
11	HE3Z 160 M 4	1470	71,5	21,5	0,81	91,4	92,7	92,4	2,4	3,35	7,8	0,10309	BC 08 170	550	147
15	□ HE3Z 160 L 4	1475	97,1	29,9	0,79	92,1	92,4	91,5	2,2	3,45	8,5	0,12827	BC 08 250	600	160
18,5	HE3Z 180 M 4	1470	120,2	34,9	0,83	92,6	92,8	92,2	1,9	3,5	6,1	0,186	BC 09 300	390	259
22	HE3Z 180 L 4	1470	142,9	41,3	0,83	93	93,2	92,8	2	2,9	6,2	0,218	BC 09 300	500	288
30	□ HE3Z 200 L 4	1470	194,9	54,6	0,85	93,6	94	93,4	1,9	2,75	6,6	0,34	BC 09 400	250	283

□ Temperature rise class F.

Technical data 400V 50 Hz

6 poli - 1000 min⁻¹
 IP 55
 IC 411
 Insulation class F
 Temperature rise class B

IE3
400V - 50Hz
ErP

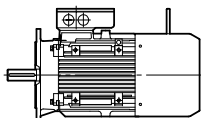

P _N	Motor	n _N	M _N	I _N	cos φ	η			M _s /M _N	M _{max} /M _N	I _s /I _N	J ₀	Brake	M _f	z ₀	kg
						IE3 IEC 60034-2-1										
kW		min ⁻¹	N m	A 400 V		100%	75%	50%			kg m ²		N m	starts/h		
7,5	HE3Z 160 M 6	970	73,8	16,2	0,75	89,1	89,3	88,3	2,1	3,3	6,9	0,10865	BC 08 170	1650	123	
11	HE3Z 160 L 6	970	108,2	22,8	0,77	90,3	90,2	89,6	2,5	3,5	7,5	0,15208	BC 08 250	1050	160	
15	HE3Z 180 L 6	980	146,2	30,8	0,77	91,2	91,5	90,7	1,9	2,7	5,6	0,34608	BC 09 300	650	280	
18,5	HE3Z 200 LR 6	985	179,4	38,3	0,76	91,7	92,4	90,2	2	3,1	6,4	0,46133	BC 09 400	340	268	
22	HE3Z 200 L 6	980	214,4	43,6	0,79	92,2	92,3	89,4	1,9	2,5	7	0,53	BC 09 400	200	278	

8.7

Motor dimensions

Mounting position
IM B5, IM B5R

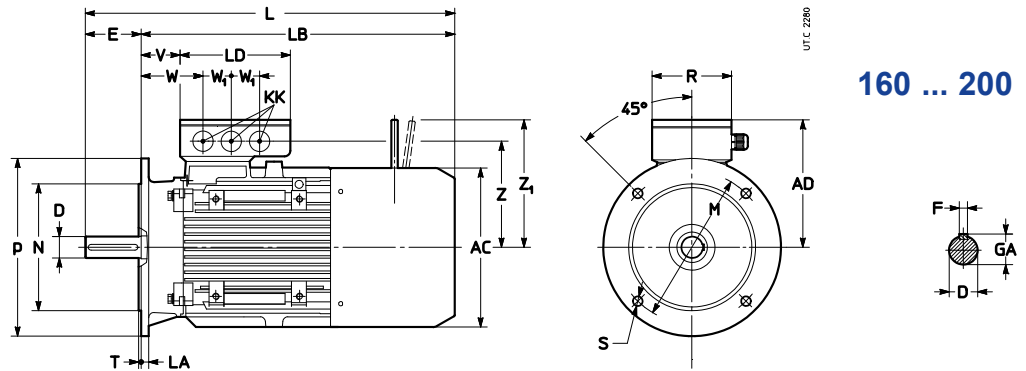

Motor size	AC	AD	L	LB	LD	KK	R	V	W	W ₁	Z	Z ₁	Shaft end				Flange							
													D	¹⁾	E	F	GA	M	N	P	LA	S	T	
160 B5R B5	315	268	710	630	240	2×M40+ 1×M16	160	80	130	55	210	266	38 k6	M12	80	10	41	265	230	j6	300	14	14	4
													42 k6	M16	110	12	45	300	250	h6	350	15	19	5
180 M B5	360	289	800	690		2×M50		87	137		225	305	48 k6	M16		14	51,5							
180 L B5			835	725																				
200 B5R B5	400	304	905	795		1×M16	190	126	186	65	250		55 m6	M20		16	59	350	300	h6	400	17		
			870	760																				

1) Tapped butt-end hole.

Mounting position
IM B3

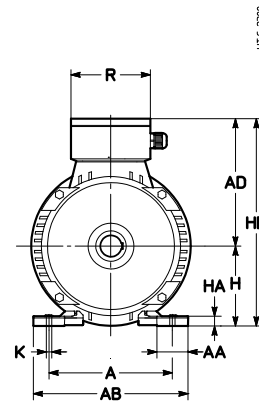
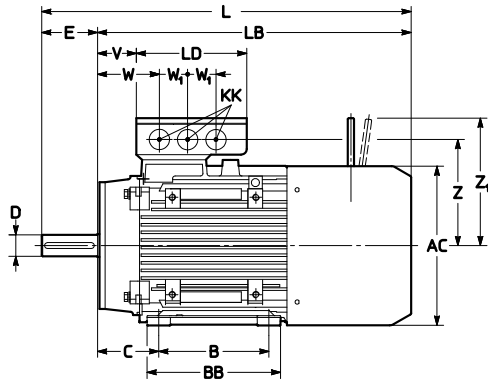

160M ... 200

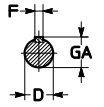

Motor size													Shaft end				Feet										
	AC	AD	L	LB	LD	KK	R	V	W	W ₁	Z	Z ₁	D	E	F	GA	A	AB	B	C	BB	AA	K	HA	H ²⁾	HD	
160 M B3	315	268	740	630	240	2×M40+	160	80	130	55	223	266	42 k6	M16	110	12	45	254	296	254	108	296	55	14	20	160	418
160L B3						1×M16																					
180 M B3	360	289	800	690		2×M50		87	137		224	305	48 k6	M16		14	51,5	279	350	241	121	315	70	15	22	180	458
180 L B3			835	725		+													279								
200 B3	400	304	870	760		1×M16	190	91	15	65	254		55 m6	M20		16	59	318	390	305	133	370	70	19	25	200	510

1) Tapped butt-end hole.
2) Tolerance $\begin{smallmatrix} 0 \\ -0.5 \end{smallmatrix}$

8.8

Non-standard designs and accessories

Ref.	Description	Non-standard design code
(1)	Non-standard motor supply	–
(3)	Insulation class H	,H
(8)	Condensate drain holes	,CD
(9)	Additional winding impregnation	,SP
(13)	Anti-condensation heater	,S
(14)	Terminal box on one side (IM B3 and derivatives)	,P...
(17)	Axial independent cooling fan	,V...
(18)	Axial independent cooling fan and encoder	,V... ,E...
(20)	Bi-metal type thermal probes	,B15
(21)	Drip-proof cover	,PP
(25)	Lever for manual release with automatic return ,L1 ,L2 ,L3	,L...
(26)	Separate d.c. brake supply	see 8,8 (26)
(35)	Light alloy fan	,VL
(36)	Encoder	,E1 ... ,E5
(47)	Design for damp and corrosive environment, stainless steel brake disc, bolts and screws	,UC, DB
(48)	IP 56 protection	,IP56
(49)	IP 65 protection	,IP65
(51)	Strengthened design for supply from inverte	
(53)	Brake with microswitch	,SB, SU
(61)	Manual rotation	,MM
(62)	Motor prearranged for encoder	,PE
(63)	Axial independent cooling fan and prearranged for encoder	,V... ,PE...

(1) Non-standard motor supply

The first two columns show the possible types of supply.

Supply values, brake rectifier and independent cooling fan are **co-ordinated** with motor winding voltage as stated in the table.

Motor wound and stated for		Non standard design available	160 ... 200		
V	Hz		Brake size 08 ... 09 Rectifier	Rectifier supply [V]	Coil voltage [Vdc]
Δ220 Y380	50	-	-	-	-
Δ230 Y400	50	-	-	-	-
Δ240 Y415	50	-	-	-	-
Δ255 Y440	60	-	-	-	-
Δ265 Y460	60	-	-	-	-
Δ277 Y480	60	-	-	-	-
Δ380	50	●	RR1	380	178
Δ400	50	●	RR1	400	178
Δ415	50	●	RR1	415	178
Δ440	60	○	RR8	440	206
Δ460	60	○	RR8	460	206
Δ480	60	○	RR8	480	206

● standard ○ on request — not foreseen

Designation: by following instructions at ch. 8.2, state **voltage** and **frequency** (in the first table columns).

(3) Insulation class H

Insulation materials in class H with permissible temperature rise in class H.

Thermistor thermal probes are supplied as standard with an intervention temperature of 170 °C (, T17).





Non-standard design code for the **designation: ,H**

(8) Condensate drain holes

It is advisable for motors operating in particularly damp environments and/or with wide variation in the temperature and/or at low temperature. In motor designation state in «MOUNTING POSITION» the designation of the real application mounting position, determining the hole position.

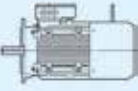
Motors are supplied with closed holes.

Non-standard design code for the **designation: ,CD**

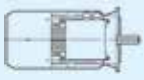
Forma costruttiva						
IM						
B3	IM 1001	IM 1011	IM 1031	IM 1051	IM 1061	IM 1071
B5	IM 3001	IM 3011	IM 3031	IM 3051	IM 3061	IM 3071

Design supplied as standard for sizes 180 ... 200.

(9) Additional winding impregnation

It consists of a second impregnation cycle after stator windings assembly standard supplied with design (48).

Useful where it is necessary to have an additional protection (of the windings) against electrical stress (voltage peaks due to rapid commutations or to «low quality» inverters with high voltage gradients) or mechanical agents (mechanical or electromagnetic vibrations: e.g. from inverter). See also ch. 2.9 «Voltage peaks (U_{max}), voltage gradients (dU/dt), cable length».

Non-standard design code for the **designation: ,SP**

(13) Anti-condensation heater

It is advisable for motors operating in particularly damp environments and/or with wide variation in the temperature and/or at low temperature; supply and power absorbed, see table below.

Motor size	Heater [W]	V a.c. ~ supply
160	50	230 V 50 / 60 Hz ± 10%
180, 200	80	

Heater must not be connected during the running.

Cables connected to fixed or loose terminal block inside terminal box.

Non-standard design code for the **designation: ,S**

(14) Terminal box on one side (for IM B3 and derivatives)

Terminal box in position P1 or P2.

Non-standard design code for the **designation:**

,P... (additional code **1** or **2** according to scheme beside).

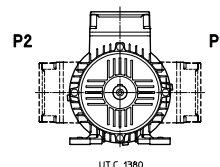

(17) Axial independent cooling

Cooling provided with **compact** axial independent cooling fan, for variable speed drives (motor may absorb nominal current for all speed range, in continuous duty cycle and without overheating) with inverter and/or for heavy starting cycles (for z_0 increases consult us).

LB dimension (see ch. 8.7) **increases** by the ΔLB quantity stated in the following table.

Specifications of independent cooling fan:

- three-phase Y only supply
- **IP 55** protection (it is the protection stated on name plate);
- supply terminals on relevant auxiliary terminal block located inside the motor terminal box

Non-standard design code for the **designation: ,VD.**

IC 416 is stated on name plate.

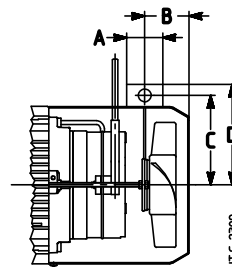

Motor size wound and stated for			Independent cooling											
Motor size	V	Hz	Independent cooling fan name plate					kg	ΔLB	A	B	C	D	Code
			V	Hz	W	A	cos φ							
160	Y380	50	Y380	50	50	0,13	0,59	7	125	74	113	189	207	,VD
	Y400		55		0,14	0,56								
	Y415		55		0,15	0,54								
	Y440	60	Y440	60	75	0,15	0,69							
	Y460		75		0,15	0,66								
	Y480		80		0,16	0,63								
180	Y380	50	Y380	50	65	0,15	0,7	8	85	74	107	210	228	
	Y400		70		0,16	0,67								
	Y415		75		0,16	0,65								
	Y440	60	Y440	60	95	0,16	0,79							
	Y460		100		0,17	0,76								
	Y480		105		0,17	0,75								
200	Y380	50	Y380	50	80	0,15	0,78	9	125	74	120	231	249	
	Y400		80		0,16	0,76								
	Y415		85		0,16	0,75								
	Y440	60	Y440	60	115	0,18	0,84							
	Y460		120		0,18	0,83								
	Y480		125		0,19	0,81								

Non-standard design code for the **designation: ,VD.**

(18) Axial independent cooling fan and encoder

Independently cooled motor equipped with hollow shaft encoder with elastic fastening.

For specifications and designation code relevant to the independent cooling fan and the encoder see designs (17) and (36), respectively.

Non-standard design code for the **designation: ,V ... ,E ...**
IC 416 is stated on name plate.

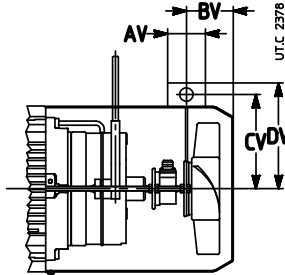

Motor size	ΔLB mm	A	B	C	D
160	140	74	113	189	207
180	158	74	107	210	228
200	180	74	120	231	249

(20) Bi-metal type thermal probes

Three bi-metal probes wired in series with usually closed contact inserted in the windings. Nominal current 1,6 A, nominal voltage 250 V a.c.. The contact opens when (delay $20 \div 60$ s) the temperature of the windings reaches the setting temperature of **150 °C (B15)**.

With design (3) «Insulation class H» if required, **bi-metal probes** with setting temperature of **170 °C (B17)** are supplied. Terminals connected to a loose or fixed terminal block inside the terminal box.

Non-standard design code for the **designation: ,B15**

(21) Drip-proof cover

Necessary design for outdoor applications or when water sprays are present, in mounting position with downwards vertical shaft (IM V1, IM V18).

LB dimension (see. ch. 8.8) increases by $\Delta LB = 60$ mm.

Non-standard design code for the **designation: ,PP**

(25) Lever for manual release with automatic return

Three-phase motors equipped with lever for manual release with automatic return and removable lever rod; position of release lever corresponding to terminal box as per schemes.

Non-standard design codes for the **designation: ,L1 (90°) ,L2 (270°) ,L3 (180°)**.

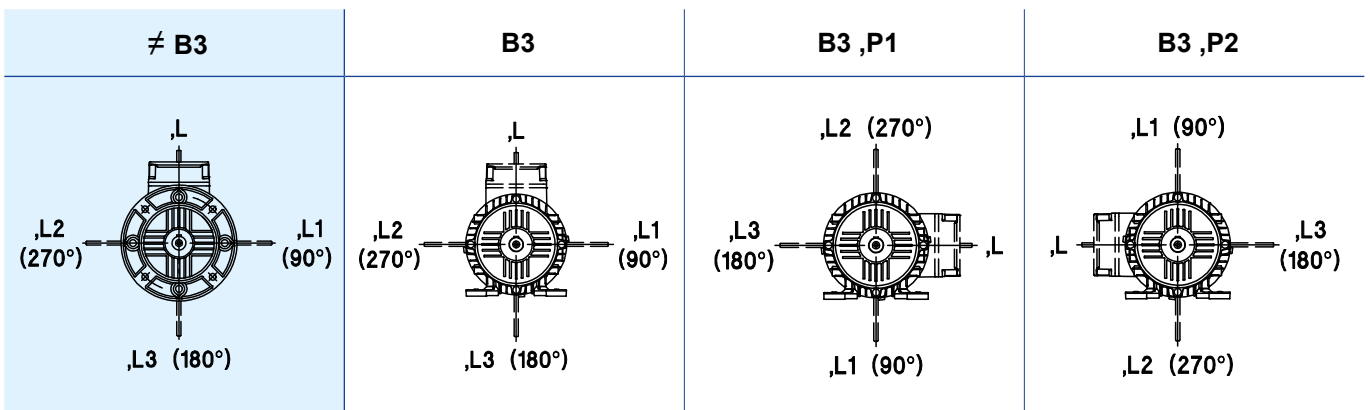

(26) Separate d.c. brake supply

Motors are supplied as standard according to ch. 8.8 (1):

Rectifier not connected to motor terminal block.

Brake separate supply is necessary in several applications (e.g.: motors driven by inverter, motors for lifting with on-load descent braking). Following rectifier input voltages are available on request.

For the **designation** use the non-standard design codes stated in the table.

Motor size	Brake size	Rectifier supply	Name plate data		
			Rectifier	Nominal brake coil voltage	Code
		V~		V cc ± 5%	
160 ... 200	08, 09	24 V c.c. ¹⁾	-	24	,F17
		110	RR5	51	,F15
		220 ... 240	RR5	103	,F1C
		255 ... 277	RR5	119	,F4
		290	RR1 ²⁾	130	,F7
		330 ... 346	RR1 ²⁾	156	,F21
		380 ... 415	RR1 ²⁾	178	,F10
		440 ... 480	RR8	206	,F12B

1) Rectifier is not supplied.

2) In case of disconnection on a.c. and d.c. side and high number of starts use a RR8 rectifier.

(35) Light alloy fan

Motor with light alloy fan (aluminum) for environments where it is not advisable to use the standard plastic fan.

Non-standard design code for the **designation**: **,VL**

(36) Encoder

Motor equipped with incremental hollow shaft encoder and elastic fastening with the following features stated in the table (free connection wirings for the use of connectors installed by the Buyer).

For different and/or additional technical specifications, consult us.

LB dimension (see ch. 8.7) **increases** by ΔLB quantity stated in the table.

Motor size	Encoder ΔLB [mm]
160	58
180	42
200	65

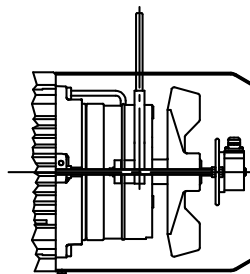

Output signal ¹⁾	RS 422 LD TTL	RS 422 TTL	Push - Pull HTL LD HTL	sin / cos	
	Supply voltage U_B	5 V d.c. \pm 5%	10 \div 30 V d.c.		5 V d.c. \pm 5%
Maximum current consumption (without load) I_N	90 mA		100 mA	110 mA	
Channels	A+, A-, B+, B-, 0+, 0-				
Output amplitude per track	$U_l \leq 0,5 V_{dc}$; $U_h \geq 2,5 V_{dc}$		$U_l \leq 0,5 V_{dc}$; $U_h \geq U_B - 1 V_{dc}$	1 $V_{pp} \pm 20\%$ (channel A, B) 0,1 \div 1,2 V (channel 0)	
Maximum output current per track I_{out}	± 20 mA		± 30 mA	-	
Maximum pulse frequency f_{max}	100 \div 300 kHz ^{2) 3)}			-	
Frequency -3 dB	-			≥ 180 kHz	
No. pulse per revolution	1024 ⁴⁾				
Vibration resistance (DIN-IEC 68-2-6)	≤ 100 m/s ² , 10 ... 2000 Hz				
Shock resistance (DIN-IEC 68-2-27)	$\leq 1\,000 \div 2\,500$ m/s ² , 6 ms ²⁾			$\leq 2\,000$ m/s ² , 6 ms	
Maximum speed	6000 min ⁻¹				
Ambient temperature	-40 °C \div 100 °C	-30 °C \div 85 °C	-40 °C \div 100 °C	-25 °C \div 85 °C	
Protection degree (EN 60 529)	IP65				
Connections	cavi liberi ⁸⁾ L = 1000 mm for use of connector installed by the user				
Encoder cable cross-sections	2 \times 0,22+6 \times 0,14 [mm ²]	10 \times 0,14 [mm ²]	2 \times 0,22+6 \times 0,14 [mm ²]	8 \times 0,22 [mm ²]	8 \times 0,22 [mm ²]
Code for designation	,E1	,E2	,E3	,E4	,E5

1) Other electronic configurations available on request; consult us.

2) Variable depending on the model.

3) Parameter to be checked depending on the combination max motor speed/pulse per revolution required.

4) Other pulse rates available on request (max 5000 ppr).

8) On request: different cable lengths, output with connector or with connector and cable; consult us.

Non-standard design code for the **designation**: ,E1 ... ,E5 (see table).

(47) Design for damp and corrosive environment

Advised for outdoor installation, in presence of humidity, in case of condensate dangers, especially for aggressive environment, includes type of impregnation with VI process, anti-oxidation paint of rotor, brake with dragging hub and brake plate (endshield end) made of stainless steel.

In these cases it is recommended to require also the design «Condensate drain holes» (8) and/or «Anti-condensation heater» (13).

For strongly aggressive environment (e.g. sea), it is possible to require also: stainless steel brake disc and anti-sticking friction surface²⁾; stainless steel bolts and screws of brake (fastening screws, bushes and nuts). In this case the motor is to be specifically purchased with «**Stainless steel brake disc, bolts and screws**»¹⁾.

With «Axial independent cooling fan and encoder» (18) and «Encoder» (36) consult us.

Non-standard design code for the **designation: ,UC**

1) Additional non-standard design code «Stainless steel brake disc, bolts and screws» for the **designation: , DB**

2) The braking torque is equal to 0,8 times the one stated in the point 8.5.

(48) IP 56 protection

It is recommended for motors running in presence of direct splash or bolts of water (includes design (9) and seal between couplings surfaces of housing and endshields (to be re-adjusted when disassembling the motor).

Brake including: dragging hub and stainless steel brake plate (endshield side).

In these cases it is advisable to require also the design «Condensate drain holes» (8) and/or «Anti-condensation heater» (13) and «Stainless steel brake disc, bolts and screws».

Non-standard design code for the **designation: ,IP 56**

Non-standard design	160 ... 200	
(17)	<input type="radio"/>	
(18)	<input type="radio"/>	
(36)	<input type="radio"/>	
(62)	<input checked="" type="radio"/>	○ Consult Rossi S.p.A.
(63)	<input type="radio"/>	● Possible

(49) IP 65 protection

Advised both for motors running in dusty environments and to avoid that wear dust of friction surface is dispersed in the environment (e.g. food industry).

Seal between the coupling surfaces of housing and endshields (to be re-adjusted when disassembling the motor).

IP 65 brake protected with: rear V-ring, O-rings on fastening screws of brake and on the pullers of the release hand lever.

In damp and/or aggressive environment, in case of condensate and/or mildew dangers or of long brake standstill, it is recommended to require the «Design for damp and corrosive environment» (47),

if necessary also with «Stainless steel bolts and screws» (described always in (47)).

Non-standard design code for the **designation: ,IP 65**

Non-standard design	160 ... 200	
(17)	<input type="radio"/>	
(18)	<input type="radio"/>	
(36)	<input checked="" type="radio"/>	
(62)	<input checked="" type="radio"/>	○ Consult Rossi S.p.A.
(63)	<input type="radio"/>	● Possible

(51) Strengthened design for supply from inverter

Advised or necessary (see ch. 2.9 «Voltage peaks (U_{max}), voltage gradients (dU/dt), cable length») for inverter supply voltages $U_N > 400$ V, voltage peaks $U_{max} > 1000$ V, voltage gradients $dU/dt > 1$ kV/ μ s, supply cable length between inverter and motor > 30 m.

It consists of special winding and impregnation cycle.

Non-standard design code for the **designation: ,IR**

(53) Brake with microswitch

Brake equipped with a mechanical microswitch in order to indicate **brake wear or brake jam/release**:

- supply: 250 V a.c. max. 6 A;
- protection degree IP 67;
- terminals are wired to a fixed or loose terminal block inside the terminal box (for wiring schemes see fig. below).

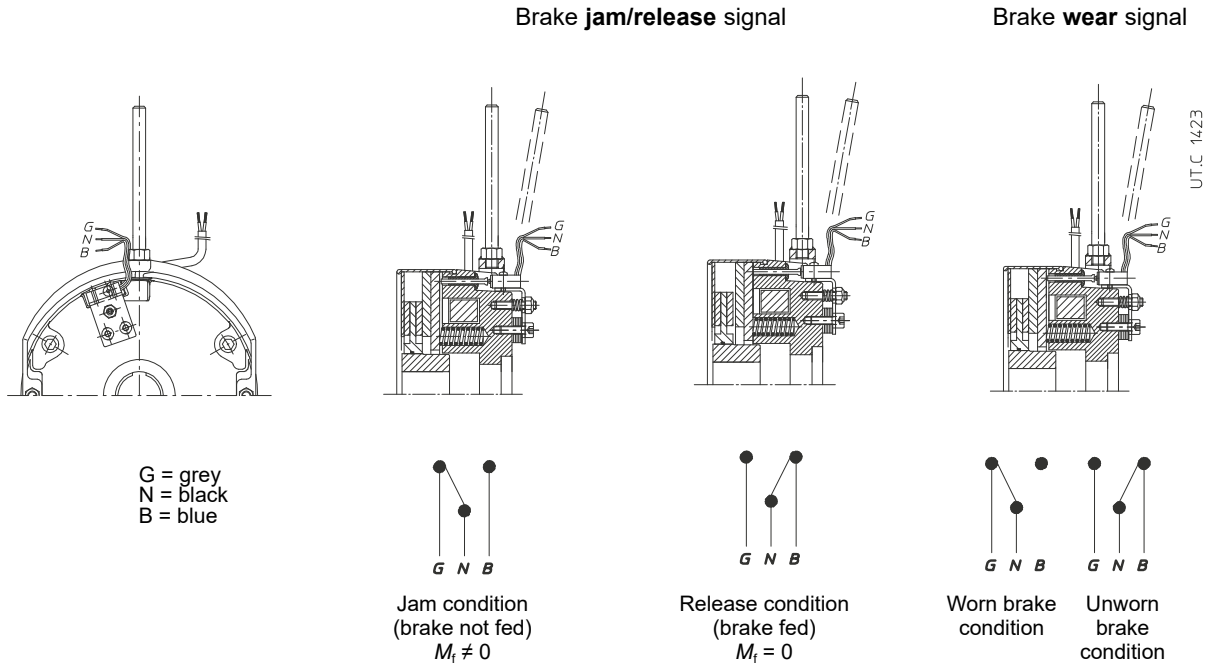

Non-standard design code for the **designation**:

,SB (brake **jam/release** signal)

,SU (brake **wear** signal)

(61) Manual rotation

Pre-arranged for **manual rotation** by straight setscrew (see table) that can be fitted on non-drive end motor shaft (excluded non-standard designs «Axial independent cooling fan» and «Axial independent cooling fan and encoder» ch. 4.8 (17), (18) and (63).

Non-standard design code for the **designation**: **,MM**

Motor size	Wrench
160 ... 200	12

(62) Motor prearranged for encoder

Motor prearranged for encoder with following features:

- anti-rotation center distance \varnothing 63 mm
- flexible anti-rotation bracket with 1 or 2 holes/slots at 180° suitable for screw passage M3
- max encoder height 48 mm
- motor shaft \varnothing 10 h6 mm.

Motor dimensions as per encoder design (36).

Non-standard design code for the **designation**: **,PE**

(63) Axial independent cooling fan and prearranged for encoder

Independently cooled motor prearranged for encoder with following features:

- anti-rotation center distance \varnothing 63 mm;
- flexible anti-rotation bracket with 1 or 2 holes/slots at 180° suitable for screw passage M3;
- max encoder height 48 mm;
- motor shaft \varnothing 10 h6 mm and length 35 mm.

For specifications and independent cooling fan designation code see design (17).

Motor overall dimensions as «Axial independent cooling fan» (17).

Non-standard design code for the **designation**: **,V... PE**

8.9

Name plate

Supply of independent cooling fan is **co-ordinated** with motor winding voltage as stated in the table.

- (1) Number of phases
- (2) Motor type
- (3) Size
- (4) Number of poles
- (5) Designation of mounting position
- (6) Protection IP ...
- (7) Maximum ambient temperature
- (8) Code IC
- (9) Production number
- (10) Two months and year of manufacturing end serial number
- (11) Motor mass
- (12) Insulation class I.CL....
- (13) Duty cycle S...
- (14) Motor code
- (15) Customer code *
- (16) Bearings
- (17) Note 1
- (18) Note 2
- (19) Connection of the phases
- (20) Nominal voltage
- (21) Voltage tolerance
- (22) Nominal frequency
- (23) Frequency tolerance
- (24) Nominal current
- (25) Nominal power
- (26) Nominal speed
- (27) Nominal power factor
- (28) Nominal efficiency IEC 60034-2-1
- (29) Design - code
- (30) Brake size
- (31) Brake braking torque
- (32) Rectifier supply
- (33) Current absorbed by brake
- (34) Rectifier designation
- (35) D.c. nominal voltage of brake supply

* on request

MOT. (1)~ (9)	(2) (3) (4) (5) (10)	IP (6)	kg (11)	AMB. (7)	I.CL. (12)	IC (8)	S (13)
(14)	Freno Brake (30)	Nm (31)	V~/Hz (32)	A (33)	#/#/#	V=	(35)
DE/NDE (16)							
(17)							
(19) V (19)	%	Hz	%	A	kW	min ⁻¹	cos φ
(20)	(21)	(22)	(23)	(24)	(25)	(26)	(27)
(28)							
(29)							

UTC 2291

Motor wound and stated for		Motor size
V	Hz	160 ... 200
Δ 220 Y380	50	-
Δ 230 Y400	50	-
Δ 240 Y415	50	-
Δ 265 Y460	60	-
Δ 277 Y480	60	-
Δ 380	50	●
Δ 400	50	●
Δ 415	50	●

160 ... 200

MOT. 3 ~	HE3Z 160L 4 B5	IP 55	kg 125	AMB. 40°C	I.CL. F	IC 411	S 1
1642457 01/19	4598127						
R000111171	Freno Brake BC08	Nm 250	V~/Hz 400/50	A 0.56	#/#/#	V=	178
CUSTOMER							
DE/NDE 6309-2Z-C3/6309-2Z-C3							
Δ V	%	Hz	%	A	kW	min ⁻¹	cos φ
380		50		30.1	15	1460	0.82
400		50		29,5	15	1465	0.80
415		50		29	15	1470	0.78
50Hz: IE3 92.1(100%) 91.9(75%) 92.1(50%)							

UTC 2293

● Standard nameplate - Not foreseen

This page is intentionally left blank.

Installation and maintenance

Section Contents

9.1	General safety instructions	220
9.2	Installation: general directions	221
9.3	Periodical maintenance	222
9.4	Connections	224

9.1

General safety instructions

Danger: electric rotating machines present dangerous parts: when operating they have live and rotating components with temperatures higher than 50 °C.

Motor should not be put into service before it has been incorporated on a machine which conforms to 2006/42/EC directive.

An incorrect installation, an improper use, the removing of protections, the disconnection of protection devices, the lack of inspections and maintenance, the inadequate connections may cause severe personal injury or property damage.

Therefore motor must be moved, installed, put into service, handled, controlled, serviced and repaired **exclusively by responsible skilled personnel** (definition to IEC 364). During each mentioned operation, follow the instructions of this catalog, the instructions and warnings relevant to each motor, all existing safety laws and standards concerning correct electric installations.

Since electric machines of this catalog are usually installed in industrial areas, **additional protection measures**, if necessary, must be adopted and assured by the person responsible for the installation.

When working on electric machine, machine must be stopped and disconnected from the power line (including auxiliary equipments). If there are electric protections, avoid any possibility of unexpected restarting, paying attention to specific recommendations on equipment application. In single-phase motors, running capacitor can remain temporarily charged keeping live the relevant terminals even after motor stop.

Before putting into service verify the correct operation of the brake and the **adequacy of braking torque** in order to avoid dangers for persons and things.

The responsibility of the correct brake running is of the final assembler who, before putting into service, must:

- make sure that braking torque meets application needs;
- respect connection instructions and any further recommendation contained in present chapter.

The trouble-free life of the brake depends on the correct periodical maintenance.

EMC directive. Asynchronous three-phase and single-phase motors supplied from the line and running in continuous duty comply with standards EN 50081 and EN 50082. No particular shieldings are necessary. This is also valid for the motor of independent cooling fan, if any.

In case of jogging operation, any disturbance generated by insertion devices must be limited through adequate wirings (as indicated by device manufacturer).

For HBV motor, the rectifier-brake coil group can comply with standards EN 50081-1 (emission levels for civil environments) and EN 50082-2 (immunity for industrial environments) by connecting in parallel to the a.c. rectifier a capacitor or a noise-reducing filter (for details, consult us; see non-standard design (28)).

Where motors are supplied by inverters it is necessary to follow the wiring instructions of the manufacturer of the inverter.

When brake is separately supplied, brake cables must be kept separate from power cables. It is possible to keep together brake cables with other cables only if they are shielded.

In case of design with encoder pay attention to following instructions: install the control electronic board as near as possible the encoder (and as far as possible from inverter, if any; if not possible, carefully shield the inverter); always use twisted pairs shielded leads connected to earth on both ends; signal cables of the encoder must be separate from the power cables (see specific instructions attached to the motor).

All above mentioned components are designed to be incorporated into equipment or complete systems and **should not be put into service before equipment or system has been made in conformity with Machinery Directive (Declaration of incorporation - Directive 2006/42/EC Art. 4.2 - II B).**

Compliance with «Low voltage» 2014/35/EU Directive: motors meet the requirements of this directive and are therefore CE marked on name plate.

Installation: general directions

On receipt, verify that motor corresponds to order and that it has not been damaged during the transport. Do not put into service any damaged motors.

Eyebolts on motors are suitable only for lifting the motor and not other machines fitted to it.

In case of **storing** the environment must be clean, dry, free from vibrations ($v_{\text{eff}} \leq 0,2 \text{ mm/s}$) and corrosive agents. Always protect motor from humidity.

Insulation resistance control. Before putting into service and after long stillstanding or storing periods it is necessary to measure insulation resistance between the windings and to earth by adequate d.c. instrument (500 V). **Do not touch the terminals during and just after the measurement because of live terminals.**

Insulation resistance, measured at 25 °C winding temperature, must not be lower than 10 M Ω for new winding, than 1 M Ω for winding run for a long time. Lower values usually denote the presence of humidity in the windings; in this case let them dry.

For full load and long lasting running or for jamming conditions, cutouts, electronic torque limiters or other similar devices should be fitted.

Where duty cycles involve a high number of on-load starts, it is advisable to utilize **thermal probes** for motor protection (fitted on the wiring); magnetothermic breaker is unsuitable since its threshold must be set higher than the motor nominal current of rating.

For no-load starts (or with very reduced load) and whenever it is necessary to have smooth starts, low starting currents and reduced stresses, adopt a reduced voltage starting (e.g.: Y- Δ starting, with starting autotransformer, with inverter, etc.).

Before wiring up to the electrical power supply make sure that the voltage corresponds to name plate data for: motor, independent cooling fan, if any, etc.

Select cables of suitable section in order to avoid overheatings and/or excessive voltage drops at motor terminals.

Make sure that the connection is according to schemes as per sheet contained in the terminal box (see point 9.4).

 Metallic parts of motors which usually are not under voltage, must be firmly **connected to earth** through a cable of adequate section and by using the proper terminal inside the terminal box marked for the purpose.

In order not to alter protection class shown on name plate, close the terminal box by correctly positioning the gasket and tightening all fastening screws. For installations in environments with frequent water sprays, it is advisable to seal the terminal box and the cable gland input using seal.

For three-phase motors the direction of rotation is clockwise (drive-end view) if connections are according to point 9.4. If direction of rotation is not as desired, invert two phases at the terminals.

In case of connection or disconnection of high polarity (≥ 6 poles) motor windings, there can be dangerous voltage peaks.

Pre-arrange the proper protection (e.g. varistors or filters) on the supply-line. The use of inverter involves some precautions relevant to its quality, to the value of mains voltage U_N , to voltage peaks (U_{max}), to voltage gradients (dU/dt) and to cable length between inverter and motor; some non-standard motor designs (to be required when ordering) and/or adequate filters to be inserted on supply line could be necessary; see ch. 2.9 «Voltage peaks (U_{max}), voltage gradients (dU/dt), cable length».

During the **installation**, position the motor so as to allow a free passage of air (on fan side) for cooling. Avoid: any obstruction to the airflow; heat sources near the motor that might affect the temperatures both of cooling air and of motor (for radiation); insufficient air recycle or any other factor hindering the steady heat exchange.

For **outdoor installation**, in presence of damp or corrosive environments the IP55 protection degree is not enough to guarantee a proper application. Therefore, apart from providing always the condensate drain holes (design (8)), in the right position and always open (except during washes) it is necessary also to adopt the «Design for damp and corrosive environment» and the «Stainless steel bolts and screws of brake» (see design (47)); additionally, «Anti-condensation heater» design (see design (13)) may be advisable.

Finally, motors should be protected whenever possible, and by whatever appropriate means, from solar radiation and from weather direct exposure; in particular, when the motor is installed with downwards vertical shaft «Drip-proof cover» becomes essential (see design (21)).

The surface to which motor is fitted must be correctly dimensioned and flattened in order to allow fastening security and motor alignment with driven machine and to avoid vibrations on the motor.

Pairings. It is recommended to machine the hole of parts keyed onto shaft ends to **H7** tolerance; for shaft ends having $D \geq 55$ mm, tolerance G8 is permissible provided that the load is uniform and light.

Before mounting, clean mating surfaces throughly and lubricate against seizure.

Assemble and disassemble with the aid of jacking **screws** and **pullers** taking care to avoid impacts and shocks which may **irremediably damage bearings**.

In case of direct fitting or coupling be sure that the motor has been carefully aligned with the driven machine. If necessary, interpose a flexible or elastic coupling.

In case of V-belt drives make sure that overhung is minimum and that driven shaft is always parallel to machine shaft. V-belts should not be excessively tensioned in order to avoid excessive loads on bearings and motor shaft.

Motor is dynamically balanced with half key inserted into the shaft end and exclusively for the nominal rotation speed; in order to avoid vibrations and unbalances it is necessary that also power transmissions are pre-balanced with half key. Before executing a possible trial run without output elements, secure the key.

Before putting into service verify the correct tightening of terminals, fastening and fitting systems.

Run the periodic maintenance in conformity with general and specific instructions for each motor type.

Running conditions

Motors are foreseen for applications at ambient temperature $-15 \div +40$ °C, maximum altitude 1 000 m according to CEI EN 60034-1 standards.

Motor running with independent cooling fan is allowed only when the fan is running.

Not allowed running conditions: application in aggressive environments having explosion danger, etc.

Check that eventual condensate drain holes are open and downwards.

9.3

Periodical maintenance

Motor periodical maintenance

During standard duty cycle, in order to avoid motor overheating, keep free from oils and/or from machining residuals (especially in textile sector) all cooling circuit (housing, air input).

Check that motor run is free from vibrations and anomalous noises. If there are vibrations check motor foundation and coupled machine balancing.

By executing controls of electric absorption, keep in mind that measured values are comprehensive of brake absorption (with brake supply directly from terminal block).

Excessive noise level, if any, could mean that bearings are damaged and should be replaced. Bearing life depends on motor applications (see point 3.4, 4.4, 5.4 and 9.3 for maximum loads on shaft ends).

For **spare part** orders, always specify full name plate data.

HBZ - HEZ brake periodical maintenance

Verify, at regular intervals, that **air-gap** is included within the values stated in the table (take the opportunity to remove the wear dust of the friction surface, if any).

Excessive air-gap value, deriving from friction surface wear, makes brake noise level rise and could prevent its electric release.

Important: an air-gap greater than max value can produce a decrease down to 0 of the braking torque due to the **clearance taking up of the release lever pullers**.

Adjust the **air-gap** by releasing the nuts **32** and by screwing the fastening screws **25** (for motor with flywheel, see 4.9.(23), it is necessary to act through the proper holes) in order to reach minimum air-gap (see table on following pages) measuring by a thickness gauge in 3 positions at 120° near the guiding bushes **29**. Tighten nuts **32** keeping in position fastening screws **25**. Verify the obtained air-gap value.

After several air-gap adjustments, verify that brake disk thickness is not lower than the **minimum** value stated in the table (also refer to table of ch. 4.5); if necessary, replace the brake disk.

When the hand lever for manual release does not run, after repeated operations, re-adjust the backlash **g** according to the table values.

Release lever rod is **not** to be left permanently installed (to avoid dangerous or inappropriate use).

Brake size	Motor size	g mm	Air-gap mm		S _{min} mm
			1)	nom. max	
BZ 12	63, 71	0,5	0,25	0,40	6
BZ 53, 13	71, 80	0,5	0,25	0,40	6
BZ 04, 14	80, 90	0,6	0,30	0,45	6
BZ 05, 15	90, 100, 112	0,6	0,30	0,45	7
BZ 06S	112	0,7	0,35	0,55	7
BZ 06, 56	132S ... 1160S	0,7	0,35	0,55	7
BZ 07	132M, 160S	0,7	0,40	0,60	7,5
BC 08	160, 180M	0,8	0,40	0,60	11
BC 09	180L, 200	0,8	0,50	0,70	13

- 1) Backlash of release lever pullers (if any) (approximate values: after an air-gap adjustment always check the brake functionality and the proper brake release).
- 2) Minimum thickness of brake disk.

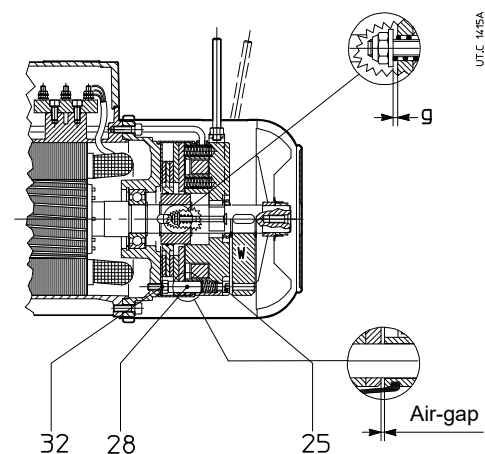

HBF brake periodical maintenance

Verify, at regular intervals, that **air-gap** is included within values stated in the table (take also the opportunity to remove the wear dust, if any).

Excessive air-gap value, deriving from friction surface wear, could produce: decrease of braking torque, rise of brake noise level, decrease of start promptness and even miss of electric release.

Adjust the air-gap as stated for **HBZ**.

After several air-gap adjustments, re-adjust braking torque and verify that brake disk thickness is not lower than **minimum** value stated in the table (also refer to table of point 5.5); if necessary, replace the brake disk.

When the hand lever for manual release does not run, after repeated operations, re-adjust the backlash **g** according to the table values.

Release lever must **not** be left permanently installed (to avoid dangerous or inappropriate use).

Brake size	Motor size	g mm	Air-gap mm		S _{min} mm
			nom.	max	
BF 12	63, 71	0,5	0,25	0,40	6
BF 53, 13	71, 80	0,5	0,25	0,40	6
BF 04, 14	80, 90	0,6	0,30	0,45	6
BF 05, 15	90, 100, 112	0,6	0,30	0,45	7
BF 06S	112	0,7	0,35	0,55	7
BF 06, 56	132	0,7	0,35	0,55	7
BF 07	132, 160S	0,7	0,40	0,60	7,5

1) Backlash of release lever pullers (if any); Approximate values: after an air-gap adjustment always check the brake functionality and the proper brake release

2) Minimum thickness of friction surface.

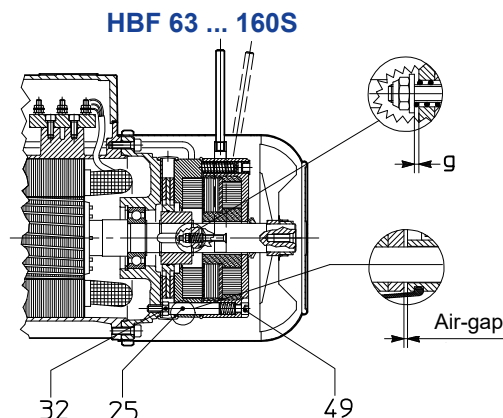

U.T.C. 14/84

HBV brake periodical maintenance

Verify, at regular intervals, that **air-gap** is included within the values stated in the table.

Excessive air-gap value, deriving from friction surface wear, could produce: decrease of braking torque even down to zero, rise of brake noise level, and even miss of electric release.

Adjust the **air-gap, also with mounted fan cover**, acting on screw **48** (HBV) keeping in mind that the pitch is: 1 mm for size 63, 1,25 mm for sizes 71 and 80, 1,5 mm for sizes 90 ... 112, 1,75 mm for sizes 132 and 160S

After several air-gap adjustments verify that the thickness of the friction surface is not lower than the **minimum** value stated in the table; if necessary, replace the brake.

Brake size	Motor size	Air-gap mm		A _{min} mm
		nom. ³⁾	max	
V 02	63	0,25	0,5	1
V 03	71	0,25	0,6	1
V 04	80	0,25	0,6	1
V 05, G5	90	0,25	0,6	1
V 06, G6	100, 112	0,30	0,65	1, 4,5 ²⁾
V 07, G7	132, 160S	0,35	0,7	4,5

1) Minimum thickness of friction surface.

2) Value for VG9.

3) Nominal value means approximate average value.

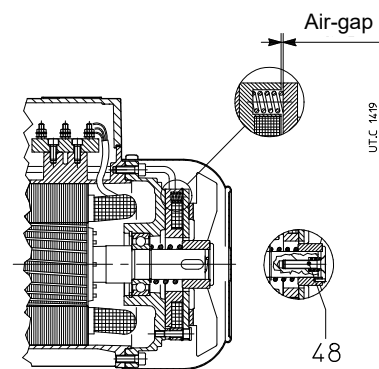

U.T.C. 14/19

9.4

Connections

Motor

For supply voltages see name plate.

Before connecting for the first time:

- **for HB series:** proceed to knockout the openings on the terminal box to allow the cable entry: after that, accurately remove every fragment still remaining inside the terminal box.
- **for HE series:** use the cable glands present as standard.

In order to restore the motor protection degree fix the cable glands (equipped with the motor for size $\geq 160M$) with lock nut, employing proper gaskets (supplied inside the terminal box for sizes $\leq 160S$).

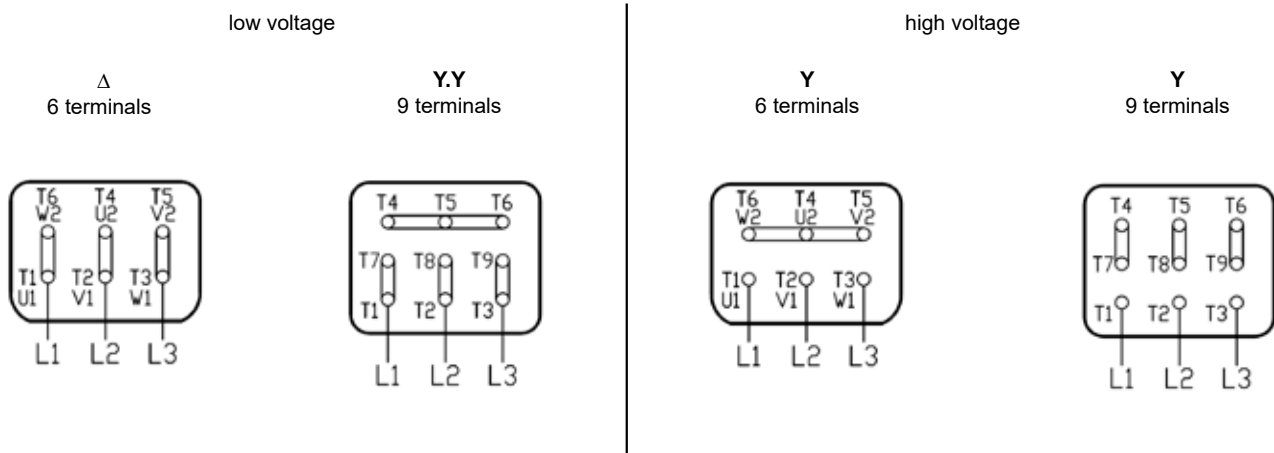

HBZ, HEZ, HBV, brake (rectifier) connection

Single-speed motors are supplied as follows:

- HBZ, HEZ, HBV $\leq 160S$: rectifier supply connected to motor terminal block. (For motor HBV 230 / 460 / 60 Y.Y / Y the rectifier supply is already connected to motor terminal block at 460 V Y, supply 230/60 Y.Y not applicable, consult us).
- HBZ, HEZ $\geq 160M$: rectifier supply not connected to motor terminal block.

For motors driven by **inverter**, and in order to **reduce the braking delay** and for lifting with on-load descent braking it is necessary to supply the rectifier **separately** with proper cables pre-arranged as shown in the schemes below (for lifting it is necessary to open the rectifier supply both on a.c. and d.c. side as stated in the figures below).

Verify that rectifier supply voltage is the one stated on motor name plate.

Rectifier connection for quick release

Rectifier RM1, RM2, RR8

t_2 (standard braking)

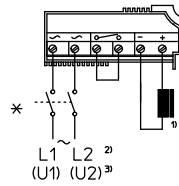

HBZ-HB2Z-HB3Z (RM1, RM2)	(T1) (T2) ³⁾	230/60 Y.Y
230/460/60 Y.Y/Y	(T1) (T5) ³⁾	460/60 Y
HBV-HB2V-HB3V	(-) (-)	230/60 Y.Y ⁴⁾
	(T1) (T2) ³⁾	460/60 Y

t_2 c.c. (fast braking)

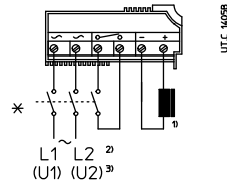

HBZ-HB2Z-HB3Z (RM1, RM2)	(T1) (T2) ³⁾	230/60 Y.Y
230/460/60 Y.Y/Y	(T1) (T5) ³⁾	460/60 Y
HBV-HB2V-HB3V	(-) (-)	230/60 Y.Y ⁴⁾
	(T1) (T2) ³⁾	460/60 Y

Rectifier RR1, RR5

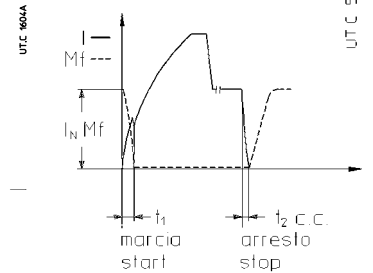
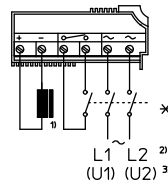
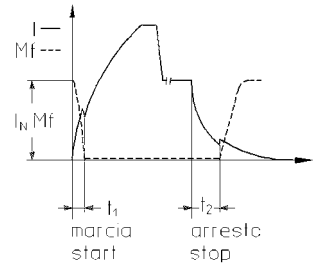
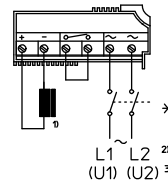

Rectifier connection for standard release

Rectifier RN1, RD1

t_2 (standard braking)

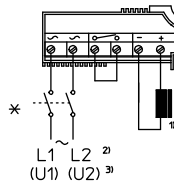

MOT. HBV-HB2V-HB3V	(-) (-)	230/60 Y.Y ⁴⁾
230/460/60 Y.Y/Y	(T1) (T2) ³⁾	460/60 Y

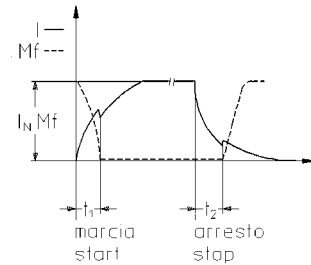

t_2 c.c. (fast braking)

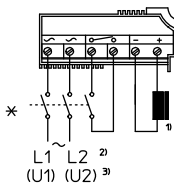

MOT. HBV-HB2V-HB3V	(-) (-)	230/60 Y.Y ⁴⁾
230/460/60 Y.Y/Y	(T1) (T2) ³⁾	460/60 Y

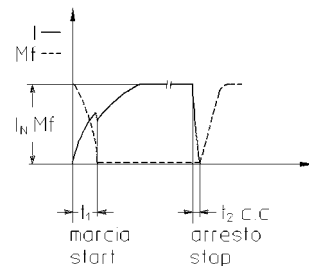

* Brake supply contactor should work in parallel with motor supply contactor; the contacts should be suitable to open very inductive loads.

1) Brake coil supplied already connected to rectifier.

2) Separate supply.

3) Motor terminal block.

4) Not applicable, consult Rossi S.p.A.

HBF brake connection

Motors are supplied, as standard, with brake coil **already Y-connected** to the brake auxiliary terminal block (brake supply **co-ordinated with motor Y voltage**); this connection has to be changed (see schemes below) only in case of direct supply from motor terminal block and motor Δ -connection or in case of separate supply with Δ voltage.

Before commissioning, connect the auxiliary terminal block to the motor terminal block (**direct** supply) or to an external line (**separate** supply).

For motors driven by **inverter** it is necessary to supply the brake separately with proper cables pre-arranged as shown in the schemes below.

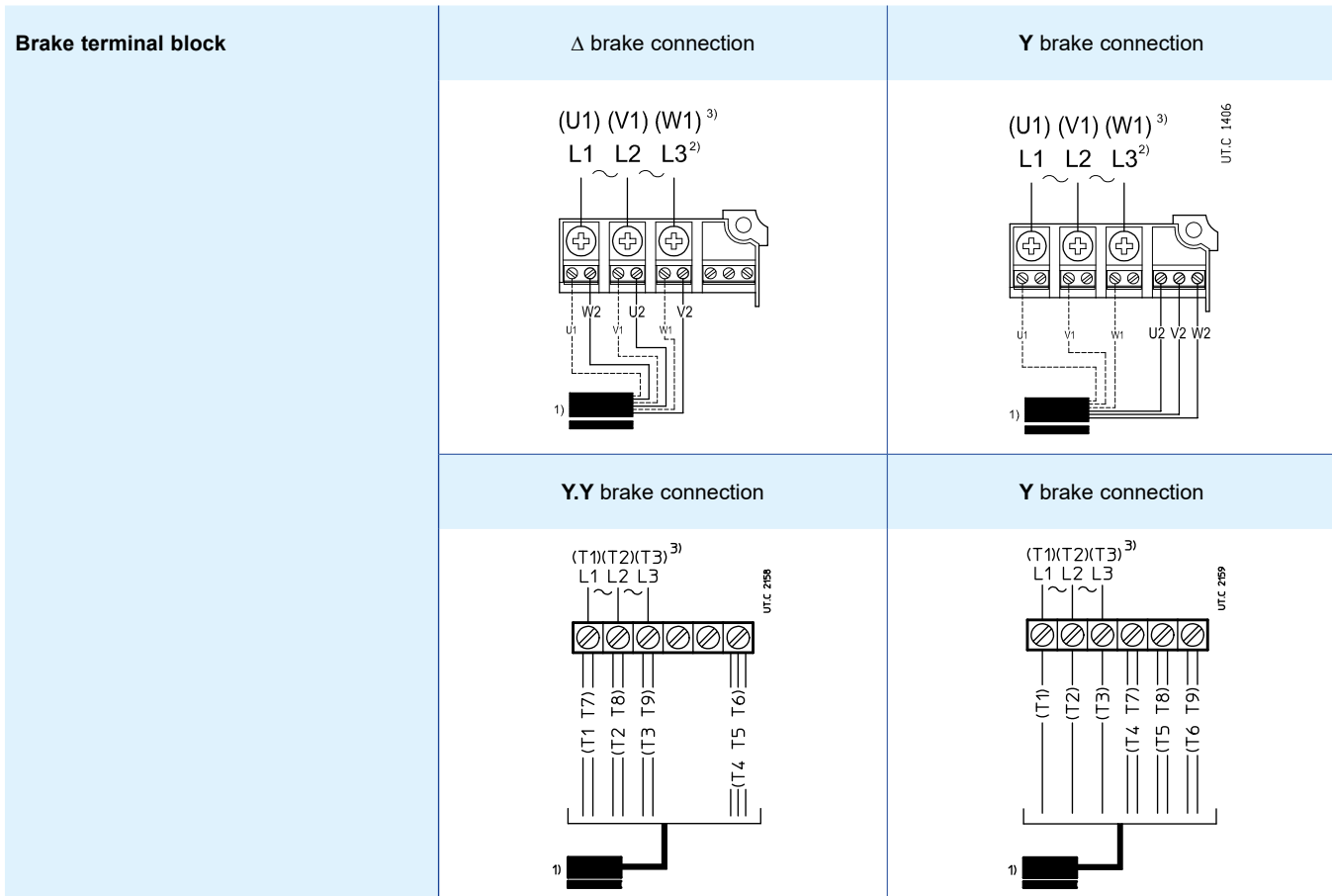

1) Brake coil is supplied already connected to the auxiliary terminal block.

2) Separate supply.

3) Motor terminal block.

Equipment connections

(independent cooling fan, thermal probes, anti-condensation heater, encoder)

Connection of independent cooling fan

For HB series motors

Supply wires of independent cooling fan are marked by the letter «V» on cable terminals and are connected to auxiliary terminal block according to following schemes, in function of identification code of independent cooling fan.

Independent cooling fan code A: connection for single-phase independent cooling fan supply (sizes 63 ... 90).

Independent cooling fan code D, F, M: connection for three-phase independent cooling fan supply (sizes 100 ... 160S); usual arrangement is with Y-connection with voltages indicated at designs 17 and 18; for Δ - connection, consult us.

For HE series motors

Cooling fan code D, M: connection for three-phase cooling fan supply (sizes 63 ... 315); the standard supply is with Y-connection for supply voltages as per designs 17 and 18;

Δ - connection is not available.

Verify that the direction of rotation of three-phase independent cooling fan is correct (air flow must be towards drive-end; see arrow on fan cover); on the contrary invert two phases at the terminals.

During the installation, verify that the supply data correspond to those of the independent cooling fan; running of motors with independent cooling fan is allowed only when external fan is running; in case of running with frequent starts and stops, it is necessary to supply the independent cooling fan continuously.

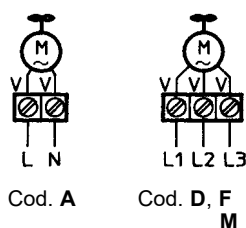

Connection of bi-metal type thermal probes, thermistor type thermal probes (PTC), anti-condensation heater

The connection wires are inside the terminal box and are marked by the letter «B» (bi-metal type thermal probes), «T» (thermistor type thermal probes PTC) or «S» (anti-condensation heater) on cable terminals; they are connected to an auxiliary terminal block according to following schemes.

Bi-metal or thermistor type thermal probes need an adequate relay or a release device.

Anti-condensation heaters must be supplied separately from motor and never during the operation.

The anti-condensation heater must be supplied for at least two hours before motor commissioning, in order to achieve a full thermal steady condition.

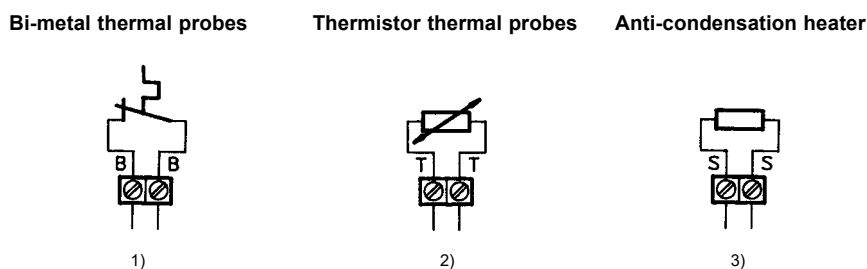

1) To control device: $V_N = 250 \text{ V}$, $I_N = 1,6 \text{ A}$.

2) Thermistor conforms to DIN 44081/44082.

3) Supply voltage single-phase $230 \text{ V a.c.} \pm 10\%$ 50 or 60 Hz (other voltage on request); power absorbed:

15 W for sizes 63 and 71,

25 W for sizes 80 ... 100,

50 W for sizes 112 ... 160,

80 W for sizes 180 ... 225,

100 W for sizes 250, 280.

In order to identify the type of design refer to mark on cables connected to auxiliary terminal block.

Connection of encoder

See specific instructions in terminal box and EMC warning at point 9.1.

Frame size

With Technical System units

With SI units

starting or stopping **time** as a function of an **acceleration** or deceleration, of a starting or braking torque

$$t = \frac{v}{a} \text{ [s]}$$

$$t = \frac{Gd^2 \cdot n}{375 \cdot M} \text{ [s]}$$

$$t = \frac{J \cdot \omega}{M} \text{ [s]}$$

velocity in rotary motion

$$v = \frac{\pi \cdot d \cdot n}{60} = \frac{d \cdot n}{19,1} \text{ [m/s]}$$

$$v = \omega \cdot r \text{ [m/s]}$$

angular velocity

$$n = \frac{60 \cdot v}{\pi \cdot d} = \frac{19,1 \cdot v}{d} \text{ [min}^{-1}\text{]}$$

$$\omega = \frac{v}{r} \text{ [rad/s]}$$

acceleration or deceleration as a function of starting or stopping time

$$a = \frac{v}{t} \text{ [m/s}^2\text{]}$$

angular **acceleration** or **deceleration** as a function of a starting or stopping time, of a starting or braking torque

$$\alpha = \frac{n}{9,55 \cdot t} \text{ [rad/s}^2\text{]}$$

$$\alpha = \frac{\omega}{t} \text{ [rad/s}^2\text{]}$$

$$\alpha = \frac{39,2 \cdot M}{Gd^2} \text{ [rad/s}^2\text{]}$$

$$\alpha = \frac{M}{J} \text{ [rad/s}^2\text{]}$$

starting or stopping **distance** as a function of an **acceleration** or deceleration, of a final or initial velocity

$$s = \frac{a \cdot t^2}{2} \text{ [m]}$$

$$s = \frac{v \cdot t}{2} \text{ [m]}$$

$$w = \frac{\alpha \cdot t^2}{2} \text{ [rad]}$$

starting or stopping **angle** as a function of an angular acceleration or deceleration, of a final or initial angular velocity

$$\varphi = \frac{n \cdot t}{19,1} \text{ [rad]}$$

$$\varphi = \frac{\omega \cdot t}{2} \text{ [rad]}$$

mass

$$m = \frac{G}{g} \left[\frac{\text{kgf s}^2}{\text{m}} \right]$$

m è l'unità di massa [kg]

weight (weight force)

G è l'unità di peso (forza peso) [kgf]

$$G = m \cdot g \text{ [N]}$$

force in vertical (lifting), horizontal, inclined motion of translation

$$F = G \text{ [kgf]}$$

$$F = m \cdot g \text{ [N]}$$

$$F = \mu \cdot G \text{ [kgf]}$$

$$F = \mu \cdot m \cdot g \text{ [N]}$$

(μ = coefficient of friction; φ = angle of inclination)

$$F = G (\mu \cdot \cos \varphi + \text{sen } \varphi) \text{ [kgf]}$$

$$F = m \cdot g (\mu \cdot \cos \varphi + \text{sen } \varphi) \text{ [N]}$$

dynamic moment Gd^2 , **moment of inertia** J due to a motion of translation

$$Gd^2 = \frac{365 \cdot G \cdot v^2}{n^2} \text{ [kgf m}^2\text{]}$$

$$J = \frac{m \cdot v^2}{\omega^2} \text{ [kg m}^2\text{]}$$

(numerically $J = \frac{Gd^2}{4}$)

torque as a function of a force, of a dynamic moment or of a moment of inertia, of a power

$$M = \frac{F \cdot d}{2} \text{ [kgf m]}$$

$$M = F \cdot r \text{ [N m]}$$

$$M = \frac{Gd^2 \cdot n}{375 \cdot t} \text{ [kgf m]}$$

$$M = \frac{J \cdot \omega}{t} \text{ [N m]}$$

$$M = \frac{716 \cdot P}{n} \text{ [kgf m]}$$

$$M = \frac{P}{\omega} \text{ [N m]}$$

work, energy in motion of translation, in rotary motion

$$W = \frac{G \cdot v^2}{19,6} \text{ [kgf m]}$$

$$W = \frac{m \cdot v^2}{2} \text{ [J]}$$

$$W = \frac{Gd^2 \cdot n^2}{7160} \text{ [kgf m]}$$

$$W = \frac{J \cdot \omega^2}{2} \text{ [J]}$$

power in motion of translation, in rotary motion

$$P = \frac{F \cdot v}{75} \text{ [CV]}$$

$$P = F \cdot v \text{ [W]}$$

$$P = \frac{M \cdot n}{716} \text{ [CV]}$$

$$P = M \cdot \omega \text{ [W]}$$

power available at the shaft of a single-phase motor
($\cos \varphi$ = power factor)

$$P = \frac{U \cdot I \cdot \eta \cdot \cos \varphi}{736} \text{ [CV]}$$

$$P = U \cdot I \cdot \eta \cdot \cos \varphi \text{ [W]}$$

power available at the shaft of a three-phase motor

$$P = \frac{U \cdot I \cdot \eta \cdot \cos \varphi}{425} \text{ [CV]}$$

$$P = 1,73 \cdot U \cdot I \cdot \eta \cdot \cos \varphi \text{ [W]}$$



Rossi

Solutions for
an evolving
industry

Rossi S.p.A.

Via Emilia Ovest 915/A
41123 Modena - Italy

info@rossi.com
www.rossi.com

2630.CAT.TX-24.02-0-EN

© Rossi S.p.A. Rossi reserves the right to make any modification whenever to this publication contents. The information given in this document only contains general descriptions and/or performance features which may not always specifically reflect those described.

The Customer is responsible for the correct selection and application of product in view of its industrial and/or commercial needs, unless the use has been recommended by technical qualified personnel of Rossi, who were duly informed about Customer's application purposes. In this case all the necessary data required for the selection shall be communicated exactly and in writing by the Customer, stated in the order and confirmed by Rossi. The Customer is always responsible for the safety of product applications. Every care has been taken in the drawing up of the catalog to ensure the accuracy of the information contained in this publication, however Rossi can accept no responsibility for any errors, omissions or outdated data. Due to the constant evolution of the state of the art, Rossi reserves the right to make any modification whenever to this publication contents. The responsibility for the product selection is of the Customer, excluding different agreements duly legalized in writing and undersigned by the Parties.